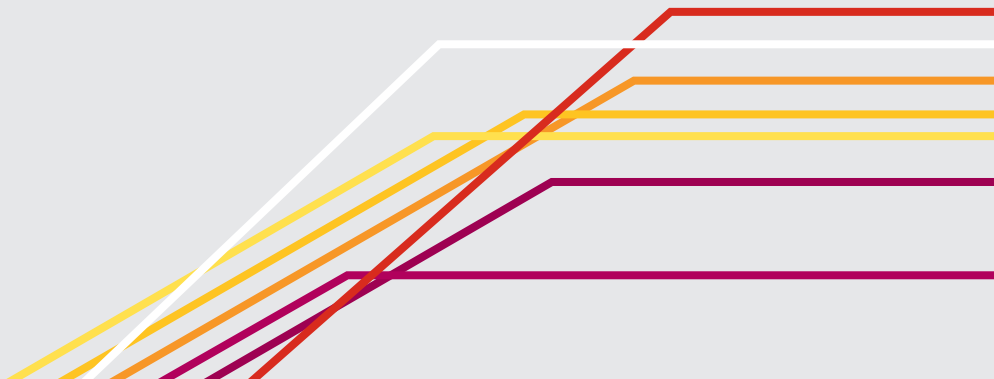




Mii

Owner's manual





Foreword

This Instruction Manual and its corresponding supplements should be read carefully to familiarise yourself with your vehicle.

Besides the regular care and maintenance of the vehicle, its correct handling will help preserve its value.

For safety reasons, note the information concerning accessories, modifications and parts changes.

If selling the vehicle, give all of the onboard documentation to the new owner, as it should be kept with the vehicle.



Table of Contents

Manual structure	5	Ensuring you are correctly and safely seated	48	Safety Assist* (City Safety Assist function)	155
		Adjusting the seat position	48	Hill hold	160
		Seat functions	55	Hill-start aid*	162
Vehicle diagram	6	Seat belts	57	Air control	164
Exterior views	6	Airbag system	67	Heating, Ventilation and Air conditioning system	164
Side view	6	Child seats (accessories)	76	At the filling station	171
Front view	7	Lights and visibility	84	Refuelling	171
Rear view	8	Lights	84	Fuel	177
Vehicle interior	9	Sun blind	89		
Driver door overview	9	Window wash/wipe system	91		
Overview of the driver side	10	Rear vision mirror	95	Care, cleaning and maintenance	180
Overview of centre console	12	Transporting	97	In the engine compartment	180
Detail of the passenger seat	14	Driving tips	97	Working in the engine compartment	180
Symbols on the roof	14	Loading luggage compartment	100	Engine oil	185
Instrument panel	15	Roof carrier system	104	Engine coolant	189
Control and warning lamps	15	Trailer coupling	107	Vehicle battery	193
Instruments	17	Practical equipment	108	Vehicle care and maintenance	197
SEAT information system	22	Storage compartments	108	Care and cleaning the vehicle exterior	197
		Drink holders	113	Caring for and cleaning the vehicle interior	205
		Ashtray and Lighter	115	Wheels and tyres	210
		Electrical power socket*	117	Accessories, replacements, repairs and modifications	222
Prior to a journey...	25			Notes for the user	233
Before starting the engine	25	While driving	119	Engine management and exhaust gas purification system	236
Tips for driving	25	Starting, changing gears, parking	119		
Unlocking and locking	28	Stopping and starting the engine	119	If and when	238
Vehicle key set	28	Changing gear	124	Practical information	238
Central locking* and locking system	33	Braking, stopping and parking	134	Frequently asked questions	238
Doors	38	Ecological driving	144	In case of emergency	240
Rear lid	40	Steering	147	Emergency locking and unlocking	243
Windows	43	Driver assistance systems	149	Vehicle tool kit*	246
Opening and closing the sliding/tilting electric panoramic sunroof	44	Parking distance warning system*	149		
		Cruise control* (Cruise control system - CCS)	152		

Wheel trims	248
Changing a wheel	250
Anti-puncture kit*	256
Fuses	261
Changing bulbs	264
Starting assistance	273
Towing and tow starting	276
Technical Data	280
Description of specifications	280
Technical specifications	280
Engine specifications	283
Dimensions	290
Capacities	290
Index	291

Manual structure

What you should know before reading the on-board manual

This manual contains a description of the **equipment** supplied with the vehicle at the time of press. Some of the equipment hereunder described will not be available until a later date, or is only available in certain markets.

Because this is a general manual for the Mii, some of the equipment and functions that are described in this manual are not included in all types or variants of the model; they may vary or be modified depending on the technical requirements and on the market; this should be in no way be interpreted as dishonest advertising.

The **illustrations** are intended as a general guide and may vary from the equipment fitted in your vehicle in some details.

The **direction indications** (left, right, front, rear) appearing in this manual refer to the normal forward working direction of the vehicle except when otherwise indicated.

The equipment marked with an asterisk** is fitted as standard only in certain versions, and is only supplied as optional extras for some versions or model years, or are only offered in certain countries.

- Ⓒ All registered marks are indicated with Ⓒ. Although the copyright symbol does not appear, it is a copyrighted mark.
- ▶ The section is continued on the following page.
- Marks the **end of a section**.



WARNING

Texts preceded by this symbol contain information on safety. They warn you about possible dangers of accident or injury.



CAUTION

Texts with this symbol draw your attention to potential sources of damage to your vehicle.



For the sake of the environment

Texts preceded by this symbol refer to relevant points concerning environmental protection.



Note

Texts preceded by this symbol contain additional information. ■

Vehicle diagram

Exterior views

Side view

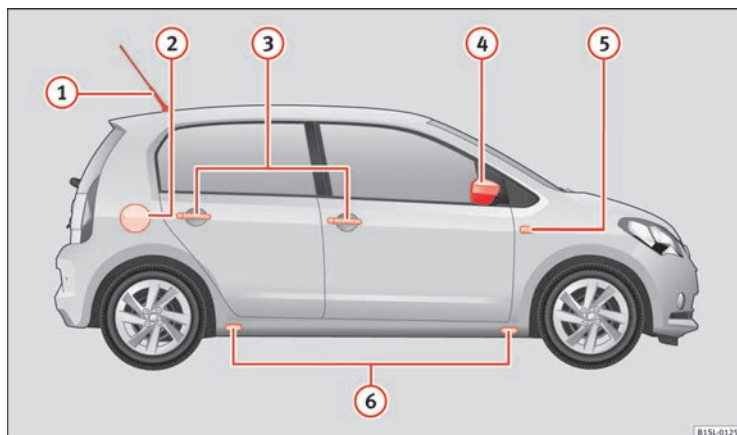


Fig. 1 Vehicle side view

Legend for the Fig. 1:

①	Roof aerial	233	③	Exterior door handle	38
②	Fuel tank plug	171	④	Exterior mirrors	95
			⑤	Additional turn signal	84, 264
			⑥	Jack position points	250 ■

Front view

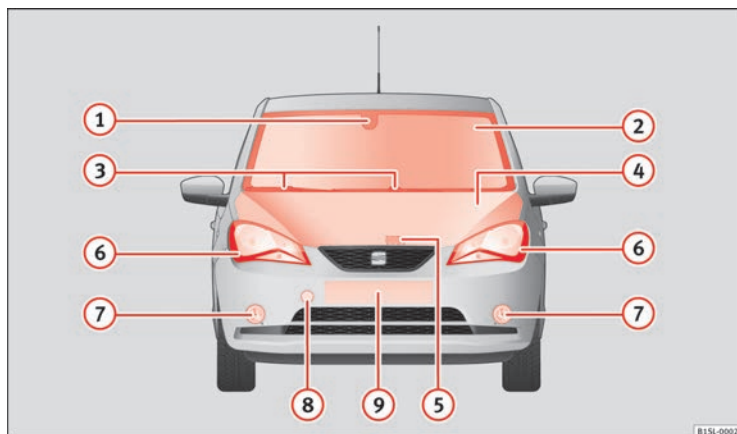


Fig. 2 Detail of the front of the vehicle

Legend for the Fig. 2:

①	Mirror support with laser sensor laser for the City Safety Assist system	155
②	Windscreen	
③	Front windscreen washer	91
④	Bonnet	180
⑤	Lever for releasing the bonnet	180
⑥	Headlight	84, 264
⑦	Fog lights	84, 264

⑧	Front towing eye housing behind a cover	276
⑨	Front number plate holder	

Vehicle diagram

Prior to a journey...

While driving

Care, cleaning and maintenance

If and when

Technical Data

Rear view

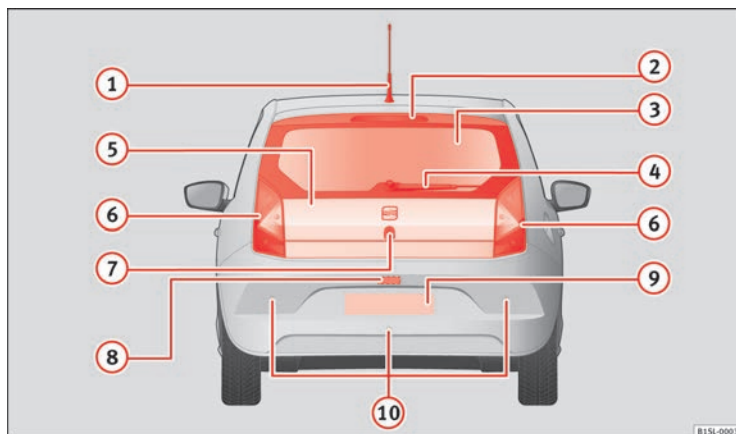


Fig. 3 Detail of the rear of the vehicle

Legend for the Fig. 3:

① Roof aerial	233	⑦ Handle with button for opening the rear lid	40
② Bulb for high-level brake lights		⑧ Registration plate light	264
③ Rear window		⑨ Rear number plate holder	
— Heated rear window	164	⑩ Sensors for the parking distance warning system	149 ■
④ Rear window wiper	91		
⑤ Rear lid	40		
⑥ Rear lights	84, 264		

Vehicle interior

Driver door overview

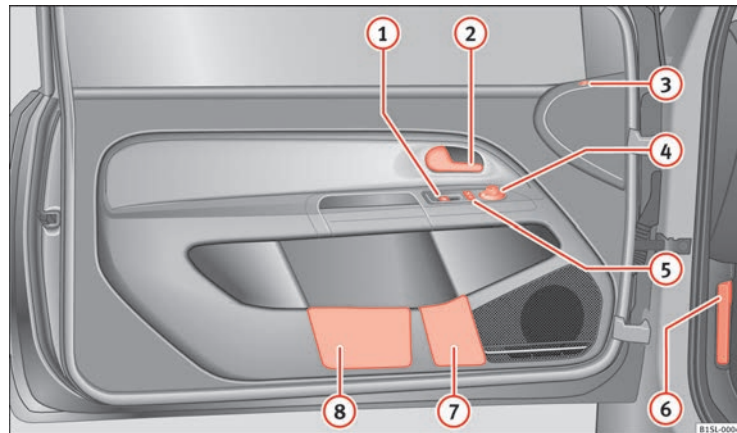


Fig. 4 Overview of the controls of the driver door

Legend for the Fig. 4:

- ① Button for operating the electric windows of the driver door 43
- ② Interior door release lever 38
- ③ Deadlock control lamp 33

- ④ Turn switch for adjusting the exterior mirrors 95
 - Exterior mirror adjustment L – 0 – R
 - Heated exterior mirrors
- ⑤ Central locking button – 33
- ⑥ Open bonnet lever 180 ▶

- ⑦ Bottle holders 113
- ⑧ Storage compartment 108

Other controls

Depending on the equipment, the vehicle may be equipped with electric window mechanical window winders, or mechanical adjustment of the rear view mirrors ⇒ page 95. ■

Overview of the driver side

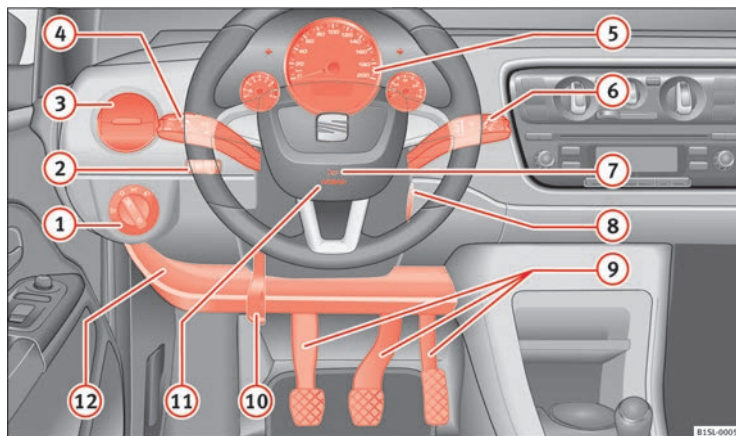


Fig. 5 Overview of the driver side ▶

Legend for the Fig. 5:

①	Light switch ☼	84	⑩	Steering column adjustment lever	48
	– Light off or daytime driving light -D		⑪	Driver front airbag	67
	– Side/dipped lights ≫◀ D		⑫	Storage compartment	108 ■
	– Fog lights 0#				
②	Headlamp range adjustment #D	84			
③	Air outlet	164			
④	Lever for	84			
	– Main beam headlights #D				
	– Headlight flasher #D				
	– Turn signals ↔				
	– Cruise control system (CCS) ON – CANCEL – OFF – RES/+ – SET/-	152			
⑤	Instrument panel:				
	– Instruments	17			
	– Digital display	17			
	– Indicator lamps	15			
⑥	Windscreen wiper/ windscreen wash lever	91			
	– Windscreen wipers HIGH – LOW				
	– Intermittent wipe ...■				
	– “Brief wipe” tx				
	– Windscreen wipers ↙				
	– Automatic windscreen wash/wipe ☼				
	– Rear window wiper ↘				
	– Automatic rear window wash/wipe ☼				
	– Lever with buttons for controlling the SEAT information system TRIP-, OK/RESET	22			
⑦	Horn (works only when the ignition is on)				
⑧	Ignition lock	119			
⑨	Pedals	124			

Overview of centre console

Top part of the centre console

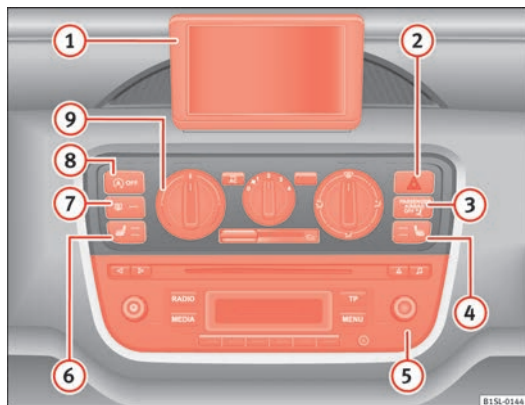


Fig. 6 Detail of the top part of the centre console

Legend for the Fig. 6:

① SEAT Portable System (supplied by SEAT)	222
② Hazard warning lights switch 	240
③ Passenger front airbag off warning lamp PASSENGER AIR-BAG OFF 	67
④ Right seat heating controls or rear window heating button (alternative position)	55, 164

⑤ Radio (factory-fitted) ⇒ Booklet Radio system, cover or storage compartment	108
⑥ Left seat heating controls 	55
⑦ Rear window heating button 	164
⑧ Start-Stop system button (A) OFF	160
⑨ Switches for:	
– Heating and ventilation system	164
– Air conditioner	164 ■

Bottom part of the centre console

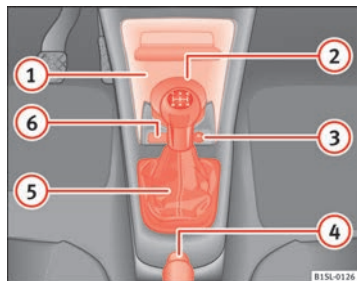



Fig. 7 Detail of the bottom part of the centre console

Legend for the Fig. 7:

- | | | |
|---|---|----------|
| ① | Storage compartment with drink holder in the centre console | 113 |
| ② | Ashtray* | 115 |
| ③ | 12 volt socket or cigarette lighter* | 117, 115 |
| ④ | Handbrake | 134 |
| ⑤ | Lever for: | |
| | – Manual gearbox | 128 |
| | – Automatic gearbox | 129 |
| ⑥ | Button for: | |
| | – City Safety Assist function  OFF | 155 ■ |

Detail of the passenger seat

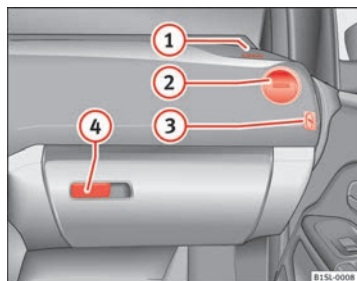


Fig. 8 Overview of the passenger side

Legend for the Fig. 8:

- | | | |
|---|--|-------|
| ① | Position of passenger front airbag on the dash panel | 67 |
| ② | Air outlet | 164 |
| ③ | In the side of the dash panel: Key switch for switching off the front passenger airbag ¹⁾ | 67 |
| ④ | Handle of the storage compartment or storage compartment open ¹⁾ | 108 ■ |



Symbols on the roof

Symbol	Meaning
	Interior lights ⇒ page 84. ■













¹⁾ According to version











Instrument panel













Control and warning lamps

The control and warning lamps are indicators of warnings, ⇒ , faults ⇒  or certain functions. Some control and warning lamps come on when the ignition is switched on, and go out when the engine starts running, or while driving.

When certain control and warning lamps are lit, an audible warning is also heard.

Symbol	Meaning ⇒ 	See
	Handbrake applied.	
	 Do not continue driving! The brake fluid level is too low or there is a fault in the brake system.	⇒ page 134
	lights up:  Do not continue driving! The liquid coolant level is too low, the engine liquid coolant temperature is too high or there is a fault in the liquid coolant system.	⇒ page 189
	flashes: Engine coolant system faulty.	⇒ page 189
	 Do not continue driving! Engine oil pressure too low.	⇒ page 185
	lights up or flashes:  Do not continue driving! Fault in the steering.	⇒ page 147
	On the instrument panel: Driver or passenger has not fastened seat belt.	
	Instrument panel display: A passenger in the rear seats has fastened their seatbelt.	⇒ page 57

Symbol	Meaning ⇒ 	See
	A passenger in the rear seats has not fastened their seat belt.	⇒ page 57
	Faulty generator.	⇒ page 193
	Vehicles with the Start-Stop system: it is necessary to start the engine manually.	⇒ page 160
	flashes in addition to the rest of the segments of the fuel gauge: Fuel tank almost empty.	⇒ page 171
	flashes quickly: The City Safety Assist system* function brakes automatically or has braked automatically. Or: flashes slowly: City Safety Assist function is not currently available.	
	The City Safety Assist* function has been connected manually. It switches off after 5 seconds.	⇒ page 155
	flashes: The City Safety Assist* function has been manually disconnected.	
InSP	after the ignition is switched on: Indication for the approach of the end of the period for an inspection to be carried out.	⇒ page 17
	lights up: ESC* faulty or disconnected by the system. ALTERNATIVELY: flashes: ESC* or ASR regulating.	
	lights up: Traction Control faulty or switched off by the system. ALTERNATIVELY: flashes: Traction Control regulator operating.	⇒ page 134
	ABS faulty or does not work.	

Symbol	Meaning ⇒ ⚠	See
	Rear fog light switched on.	⇒ page 84
	lights up or flashes: Fault in catalytic converter.	⇒ page 236
EPC	Fault in engine management.	
	lights up or flashes: Fault in the steering system.	⇒ page 147
	Fuel tank almost empty.	⇒ page 171
	Fault in airbag system and seat belt tensioners.	⇒ page 67
	lights up: the Start-Stop system is enabled. ALTERNATIVELY: flashes: the Start-Stop system is not available.	⇒ page 160
	The Start-Stop system is enabled but the engine cannot be automatically stopped.	
	Left or right turn signal.	⇒ page 84
	Hazard warning lights on.	⇒ page 240
	Cruise control operating.	⇒ page 152
	Main beam on or flasher on.	⇒ page 84
	The natural gas engine coolant temperature is too low.	



WARNING

If the warning lamps are ignored, the vehicle may stall in traffic, or may cause accidents and severe injuries.

- Never ignore the warning lamps.
- Stop the vehicle safely as soon as possible.
- Park the vehicle away from the traffic, ensuring that there are no easily inflammable materials under the vehicle which could come into contact with the exhaust system (e.g. dry grass, fuel).
- A faulty vehicle represents a risk of accident for the driver and for other road users. If necessary, switch on the hazard warning lamps and put out the warning triangle to advise other drivers.
- Before opening the bonnet, switch off the engine and allow it to cool.
- In any vehicle, the engine compartment is a hazardous area and could cause severe injuries ⇒ page 180.



CAUTION

Failure to heed the warning lamps when they appear may result in faults in the vehicle. ■

Instruments

Introduction

Additional information and warnings:

- Indicator lamps ⇒ page 15
- Gear engaged display (automatic gearbox) ⇒ page 124
- Instructions for inspection intervals ⇒ Booklet Maintenance Programme



WARNING

Any distraction may lead to an accident, with the risk of injury.

- Do not handle the instrument panel controls when driving. ■

Detail of instrument panel



Fig. 9 Instrument panel, on dash panel: variant 1



Fig. 10 Instrument panel, on dash panel: variant 2

Details of the instruments ⇒ Fig. 9 or ⇒ Fig. 10:






- ① **Speedometer.** Depending on the vehicle in km/h or in mph.
- ② **Displays on the screen.** 19

- ③ **Reset rotary control** for the odometer (trip).
 - Press the button **0.0/SET** *briefly* to switch between trip recorder and odometer.
 - Press the button **0.0/SET** *for approximately 5 seconds* to reset the odometer to zero and, where necessary, other signals of the multifunction display.
- ④ **Fuel reserve display.** 171 ▶

- 5 **Rev counter** (with the engine running, in thousands of revolutions per minute).

The beginning of the red zone of the rev counter indicates the maximum speed in any gear after running-in and with the engine hot. However, it is advisable to change up a gear or move the selector lever to **D** (or lift your foot off the accelerator) before the needle reaches the red zone ⇒ ⑩.

- 6 **Clock set button.**

- If necessary, change the time display by pressing the top and bottom buttons of the rocker switch ⇒ Fig. 11 ⑧.
- Press the button  to change the hour, so that it is flashing.
- To continue setting the time, press button . Hold button down to scroll through the numbers quickly.
- Press the button  again to change the minutes, so that it is flashing.
- To continue setting the time, press button . Hold button down to scroll through the numbers quickly.
- Press button  again to end the clock setting.



CAUTION

- When the engine is cold, avoid high revs and heavy acceleration and do not make the engine work hard.
- To prevent damage to the engine, the rev counter needle should only remain in the red zone for a short period of time.



For the sake of the environment

Changing up a gear in time reduces fuel consumption and noise.



Note

On the screen of the SEAT Portable System (supplied by SEAT) ⇒ page 222 the other instruments can be seen, such as an outside temperature indicator. ■




Display messages

A variety of information can be viewed on the instrument panel display ⇒ Fig. 9 and ⇒ Fig. 10 ②, depending on the vehicle equipment:

- Warning and information messages
- Odometer
- Time
- Outside temperature
- Selector lever positions ⇒ page 124
- Recommended gear (manual gearbox) ⇒ page 124
- Multifunction display (MFI) ⇒ page 22
- Service interval display ⇒ page 21
- Start-Stop system status display ⇒ page 160
- Fuel gauge ⇒ page 171
- Seat belt status display for rear seats ⇒ page 57

Warning and information messages

The system runs a check on certain components and functions when the ignition is switched on and while the vehicle is moving. Faults in the operation are displayed on the screen using red and yellow symbols on the instrument panel display (⇒ page 15) and, in some cases, with audible warnings. The display may vary according to the type of instrument panel fitted. ►


Type of message	Symbol colour	Meanings
Priority 1 warning.	Red	Symbol flashing or lit; partly combined with audible warnings.  Stop the vehicle! It is dangerous ⇒  ! Check the function that is faulty and repair it. If necessary, request assistance from specialised personnel.
Priority 2 warning.	Yellow	Symbol flashing or lit; partly combined with audible warnings. A faulty function, or fluids which are below the correct levels may cause damage to the vehicle! ⇒  . Check the faulty function as soon as possible. If necessary, request assistance from specialised personnel.

Odometer

The *odometer* registers the total distance travelled by the vehicle.

The *odometer (trip)* shows the distance travelled since the last odometer reset. The last figure indicates 100 m.

Outside temperature indicator

When the outside temperature is below +4 °C (+39 °F), the symbol “ice crystal” (warning of risk of freezing) is also displayed next to the temperature. At first this symbol flashes and then it remains lit until the outside temperature rises above +6 °C (+43 °F) ⇒ .

When the vehicle is stationary or travelling at very low speeds, the temperature displayed may be slightly higher than the actual outside temperature as a result of heat coming from the engine.

The temperatures measured range from -40 °C to +50 °C (-40 °F to +122 °F).

Selector lever positions

The range of engaged gears of the selector lever is shown on the side of the lever, and on the instrument panel display. In positions **D** and **M**, and with the Tiptronic, the corresponding gear is also indicated on the display.

Recommended gear* (manual gearbox)

The recommended gear to save fuel can be displayed on the instrument panel display while you are driving ⇒ page 124.

Seat belt status display for rear seats *

The seat belt status display on the instrument panel display informs the driver, when the ignition is switched on, whether any passengers in the rear seats have fastened their seat belts ⇒ page 57.

Start-Stop system status display

The instrument panel display shows information on the current status ⇒ page 160.



WARNING

If the warning lamps are ignored, the vehicle may stall in traffic, or may cause accidents and severe injuries.

- Never ignore the warning lamps.
- Stop the vehicle safely as soon as possible.
- A faulty vehicle represents a risk of accident for the driver and for other road users. If necessary, switch on the hazard warning lamps and put out the warning triangle to advise other drivers.
- Park the vehicle away from the traffic, ensuring that there are no easily inflammable materials under the vehicle which could come into contact with the exhaust system (e.g. dry grass, fuel).

**WARNING**

Although the outside temperature is above freezing, some roads and bridges may be frozen.

- At an outside temperature of above +4 °C (+39 °F), even when the “ice crystal” is not visible, there may still be ice on the road.
- Never rely totally on the outside temperature indicator!

**CAUTION**

Failure to heed the warning lamps when they appear may result in faults in the vehicle.

**Note**

Different versions of the instrument panel are available and therefore the versions and instructions on the display may vary.

**Note**

When several warnings are active at the same time, the symbols are shown successively for a few seconds. The symbols will stay on until the fault is rectified.

Service interval display

The inspection display appears on the instrument panel display → Fig. 9 or → Fig. 10 ②.

SEAT makes a difference between services *with* engine oil change (Maintenance Service) and services *without* engine oil change (Inspection Service). The service interval display only gives information for service dates which involve an engine oil change. The dates of the remaining services (for example, the next Inspection Service or change of brake fluid) are listed on the label attached to the door strut, or even in the Maintenance Programme.

The set service intervals have been specified with **the service dependent on time/distance travelled**.

Inspection reminder

If the inspection period is due to expire shortly, **Inspection reminder** appears when starting the ignition abbreviated to **hSP** and a warning in **km**. The number of kilometres shown is the maximum number that may be driven until the next service.

Service due

After **the service date**, an audible warning is given when the ignition is switched on and the abbreviation **hSP** displayed on the screen flashes for a few seconds.

**Note**

The service message disappears after a few seconds, when the engine is started or when **OK** is pressed on the windscreen wiper lever.

**Note**

In vehicles in which the battery has been disconnected for a long period of time, it is not possible to calculate the date of the next service. Therefore the service interval display may not be correct. In this case, please check the maximum permitted service intervals ⇒ Booklet Maintenance Programme.

SEAT information system

Introduction

With the ignition switched on it is possible to access different messages via the display on the instrument panel display.

The number of messages displayed on the instrument panel display will vary according to the vehicle electronics and equipment.

A specialised dealer will be able to programme or modify additional functions, according to the vehicle equipment. SEAT recommends visiting a Technical Service.

Additional information and warnings:

- Instrument panel ⇒ page 18
- Exterior mirrors ⇒ page 95
- Driver assistance systems ⇒ page 149
- Radio system ⇒ Booklet Radio system

WARNING

Any distraction may lead to an accident, with the risk of injury.

- Do not consult the messages on the instrument panel screen when driving.



Note

On the screen of the SEAT Portable System (supplied by SEAT) ⇒ page 222 other functions of the vehicle can be seen.

Control functions of the instrument panel display



Fig. 11 Windscreen wiper lever: button (A) to confirm the options and rocker switch (B) to change the options

Calling up options

- Switch the ignition on.
- If a message or vehicle symbol is displayed, press **OK/RESET** (⇒ Fig. 11 (A)).
- Press the top or bottom part of the rocker switch (B) until the desired option appears.

Multifunction display (MFI)

The multifunction display (MFI) has two automatic memories: **1 - Partial memory** and **2 - Total memory**. The selected memory will be shown in the lower right-hand corner of the display.

With the ignition switched on, and memory 1 or 2 displayed, briefly press **OK** to change from one memory to another.

1	Trip memory (for a single journey).	The memory stores the values for the journey and the consumption from the moment the ignition is switched on until it is switched off again. If the journey is broken for more than 2 hours, the memory is automatically erased. If the journey is continued in less than 2 hours after the ignition is switched off, the new data is added to the data already stored in the memory.
2	Total memory (for all journeys).	The memory stores the values of any number of journeys, until it counts a total of 19 hours and 59 minutes of driving, or 1999.9 km or miles of driving, depending on the type of instrument panel fitted. On reaching either of these limits, the memory is automatically erased and starts to count from 0 again.

Possible displays

Menu	Function
Time	Current time in hours (h) and minutes (min).
Journey duration	This indicates the hours (h) and minutes (min) since the ignition was switched on.
Current fuel consumption	The current fuel consumption display operates throughout the journey, in litres/100 km; and with the engine running and the vehicle stopped, in litres/hour.
Average fuel consumption	After turning on the ignition, average fuel consumption in litres/100 km will be shown after travelling approximately 100 metres. Otherwise horizontal lines are displayed. The value shown is updated approximately every 5 seconds.
Distance to empty (the distance you can travel with the remaining fuel)	Approximate distance in km that can still be travelled with the fuel remaining in the tank, assuming the same style of driving is maintained. This is calculated using the current fuel consumption.

Menu	Function
Distance covered	Distance travelled, after ignition is switched on, in km.
Average speed	After starting the ignition, the average speed will be shown after a distance of approximately 100 metres has been travelled. Otherwise horizontal lines are displayed. The value shown is updated approximately every 5 seconds.
Digital display of speed	Current speed displayed digitally.
Liquid coolant temperature digital display	Digital display of the current temperature of the engine liquid coolant.
Warning at --- km/h	If the stored speed is exceeded (between 30-250 km/h, or 18-155 mph), an audible warning is given together with a visual warning.

Changing between display modes

- Press the rocker switch in the windscreen wiper lever.

Storing a speed for the speed warning

- Select the display **Speed warning at --- km/h**.
- Press **OK** on the windscreen wiper lever to store the current speed and switch off the warning.
- In addition, set the required speed by pressing the rocker switch on the windscreen wiper lever or buttons **Δ** or **▽** on the multifunction steering wheel for 5 seconds. Next, press **OK** again or wait a few seconds. The speed is stored and the warning activated.
- *To switch off*, press **OK**. The stored speed is deleted.

Manually erasing memory 1 or 2

- Select the memory to be erased.
- Press and hold the eject button **OK** for approximately 2 seconds. ▶

**Note**

On the screen of the SEAT Portable System (supplied by SEAT) ⇒ page 222 other functions of the multifunction display can be seen. ■

Prior to a journey...

Before starting the engine

Tips for driving

Introduction

Depending upon how you expect to use your vehicle, it may be a good idea to protect the engine from below. A guard underneath the engine may help to reduce the risk of damage to the lower part of the vehicle and the oil sump when driving over kerbs, or along dirt tracks or rough roads... Before installation, SEAT recommends going to a SEAT dealership.

Additional information and warnings:

- Ensure you are correctly seated ⇒ page 48
- Transporting ⇒ page 97
- Starting, changing gears, parking ⇒ page 119
- Ecological driving ⇒ page 144
- Notes for the user ⇒ page 233


WARNING

Driving under the influence of alcohol, drugs, medication or narcotics may result in severe accidents and even loss of life.

- Alcohol, drugs, medication and narcotics may significantly alter perception, affect reaction times and safety while driving, which could result in the loss of control of the vehicle.

Journey preparations and safe driving

Check list

For your own safety, for the safety of vehicle occupants in the vehicle, and for that of other road users, the following should be checked before and during each journey ⇒ :

- ✓ Check that the lights and turn signals operate correctly.
- ✓ Check the tyre pressures (⇒ page 210) and level of fuel (⇒ page 171).
- ✓ Ensure there is good visibility through all the windows.
- ✓ Make sure that all objects and bags in the storage compartments, in the luggage compartment and, where applicable, on the roof, are securely fastened ⇒ page 97.
- ✓ Ensure there is nothing obstructing the free passage of the foot pedals.
- ✓ Use child retention systems appropriate for the child's body weight and height ⇒ page 76.
- ✓ Correctly adjust front seat, head rests and rear-view mirrors to suit your height ⇒ page 48, ⇒ page 95.
- ✓ Wear close-fitting shoes which do not prevent you from using the pedals correctly.
- ✓ The driver's floor mat in the footwell should be fixed to the floor, leaving the pedal area unobstructed.
- ✓ Before starting out, ensure you are correctly seated and remain in this position throughout the journey. This applies to all passengers in the vehicle ⇒ page 48. ▶

Check list (Continued)

- ✓ Correctly fasten your seat belt before starting to drive and keep it securely fastened throughout the journey. This applies to all passengers in the vehicle ⇒ page 57.
- ✓ Never carry more passengers than the number of available seats and seat belts in your vehicle.
- ✓ Never drive with impaired faculties (for example, due to medication, alcohol or drugs).
- ✓ Do not allow yourself to be distracted from the traffic, for example, to reset or switch on a menu, by other passengers or to answer a phone call.
- ✓ Always try to adapt the speed of the vehicle and your style of driving to the condition of the ground or the road and to weather and traffic conditions.
- ✓ Observe the highway code and speed limits.
- ✓ On long journeys, rest at regular intervals (at least every 2 hours).
- ✓ If carrying animals, make sure they are correctly restrained in accordance with their weight and size.

**WARNING**

Always observe traffic regulations and speed limits and try to anticipate traffic movements. Correctly anticipating traffic situations may mean the difference between arriving safe and sound at your destination or having a serious accident.

**Note**

Regular servicing of your vehicle not only helps to keep it in good working order but also helps to ensure road safety. Therefore, please ensure the vehicle is taken for service as indicated in the Maintenance Programme. If the vehicle is subjected to hard use, it may require certain maintenance work before the next service date. Hard use may involve frequent driving in traffic jams or driving in dusty areas. For further information, please refer to a SEAT dealership or a specialised workshop. ■

Driving abroad**Check list**

In some countries, certain safety regulations and requirements are in force relating to exhaust gas emissions, which differ from the technical characteristics of the vehicle. Before travelling abroad, SEAT recommends you consult a SEAT dealership about the legal requirements and the following points:

- ✓ Does the vehicle need technical modifications for driving abroad, for example, adjustment of the headlamps?
- ✓ Does the vehicle have all the tools, diagnostics equipment and spare parts required for inspections and repairs?
- ✓ Are there any SEAT dealers in the destination country?
- ✓ For petrol vehicles: Is unleaded petrol available at the right octane rating?
- ✓ Are a suitable engine oil (⇒ page 185) and other engine fluids complying with SEAT specifications available in the destination country?
- ✓ Does the Portable Navigation System (supplied by SEAT) function ⇒ page 222 in the destination country with the available navigation information?
- ✓ Are special tyres required in the destination country? ▶

 **CAUTION**

SEAT does not accept liability for any damage to the vehicle due to the use of a lower quality fuel, an inadequate service or the non-availability of genuine spare parts.

 **CAUTION**

- Driving through flooded areas may severely damage vehicle components such as the engine, transmission, running gear or electrical system.
- Never drive through salt water as salt causes corrosion. Always rinse any parts of the vehicle which have been in contact with salt water.

Driving along flooded roadways

To prevent damage to the vehicle when driving through water, for example, along a flooded road, please observe the following:

- Check the depth of the water before entering the flooded zone. The water should **never** come above the lower edge of the bodywork ⇒ ①.
- Do not drive faster than a pedestrian.
- Do not stop in the water, use reverse gear or switch off the engine.
- Oncoming traffic will cause waves which raise the level of the water, making it difficult to cross the water.
- Disconnect the Start-Stop system whenever crossing water.

 **WARNING**

When driving through water, mud, melted snow, etc., please remember that due to damp or frozen brake discs and pads in winter, the braking effect may be delayed, therefore the required braking distance is greater.

- “Dry the brakes and remove ice” by braking carefully. Ensure that you are not endangering other road-users or breaking traffic regulations in the process.
- After driving through water, avoid sudden sharp manoeuvres.

Unlocking and locking

Vehicle key set

Introduction

Additional information and warnings:

- Adjustments to the SEAT information system ⇒ page 22
- Central locking and locking system ⇒ page 33
- Start and stop the engine ⇒ page 119
- Notes for the user ⇒ page 233
- Emergency locking and unlocking ⇒ page 243

WARNING

Swallowing batteries with a diameter of 20 mm or other types of lithium battery may quickly result in serious injuries or even death.

- Always keep the vehicle keys and the key tab with the batteries, spare batteries, flat batteries and other types of batteries larger than 20 mm out of the reach of children.
- Immediately seek medical assistance if you suspect the swallowing of a battery.

WARNING

Careless or incorrect use of vehicle keys may result in severe injury and accident.

- Always take all the keys with you whenever you leave the vehicle. Children and unauthorised individuals could lock the doors or the rear lid, start the engine or turn the ignition on activating electrical systems, for example: the electric windows.
- Never leave children or disabled people alone in the vehicle. They could be trapped in the vehicle in an emergency and will not be able to get themselves to safety. For example, depending on the time of the year, temperatures inside a locked and closed vehicle can be extremely high or extremely low resulting in serious injuries and illness or even death, particularly for young children.
- Never remove the key from the ignition if the vehicle is in motion. The steering may lock and it will not be possible to turn the steering wheel. ■

Remote control vehicle key*



Fig. 12 Remote control key

Remote control key

With the vehicle key the vehicle may be locked or unlocked remotely
⇒ page 33.

The vehicle key includes an emitter and battery. The receiver is in the interior of the vehicle. The range of the vehicle key with remote control and new battery is several metres around the vehicle.

If it is not possible to open or close the vehicle using the remote control key, this should be re-synchronised ⇒ page 31 or the battery changed
⇒ page 31.

Different keys belonging to the vehicle may be used.

Folding the key shaft in and out

When the button is pressed ⇒ Fig. 12 A, the key shaft is released and unfolds.

To *fold it* press the button and fold the key shaft in until it locks in place.

Duplicate keys

To obtain a spare key and other vehicle keys, the vehicle chassis number is required.

Each new key must contain a microchip and be coded with the data from the electronic vehicle immobilizer. In vehicle key will not work if it does not contain microchip or the microchip has not been encoded. This is also true for keys cut for the vehicle.

The vehicle keys or new spare keys can be obtained from a SEAT dealership, a Specialised workshop or approved key service qualified to create this kind of key.

Synchronise new keys or spare keys before use ⇒ page 31.

⚠ CAUTION

The remote control key contains electronic components. Protect the vehicle keys from damage, impacts and humidity.

ℹ Note

Only use the key button when you require the corresponding function. Pushing the button unnecessarily could accidentally unlock the vehicle or trigger the alarm. It is also possible even when you are outside the radius of action.

ℹ Note

Remote control key operation can be greatly influenced by overlapping radio signals around the vehicle working in the same range of frequencies (for example, radio transmitters, mobile telephones).

ℹ Note

Obstacles between the remote control and the vehicle, bad weather conditions and discharged batteries can considerably reduce the range of the remote control. ▶

**Note**

If the buttons of the vehicle key are pressed ⇒ Fig. 12 or one of the central locking buttons ⇒ page 33 is pressed repeatedly in short succession, the central locking briefly disconnects as protection against overloading. The vehicle is then unlocked. Lock the vehicle if necessary.

Vehicle mechanical key



Fig. 13 Vehicle mechanical key

The vehicle key set may include a mechanical key ⇒ Fig. 13.

Duplicate keys

To obtain a spare key and other vehicle keys, the vehicle chassis number is required.

Each new key must contain a microchip and be coded with the data from the electronic vehicle immobilizer. In vehicle key will not work if it does not contain microchip or the microchip has not been encoded. This is also true for keys cut for the vehicle.

The vehicle keys or new spare keys can be obtained from a SEAT dealership, a Specialised workshop or approved key service qualified to create this kind of key.

Control lamp on the vehicle key



Fig. 14 Control lamp on the vehicle key

When a button on the vehicle key is pressed, the control lamp flashes ⇒ Fig. 14 (arrow) once briefly. If the button is pressed and held, the indicator blinks several times, for example: for the convenience opening function.

When the control lamp does not light upon pushing a button, change the batteries of the vehicle key ⇒ page 31.

Changing the battery

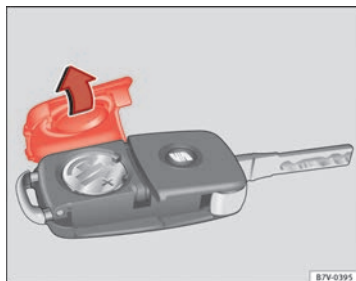


Fig. 15 Vehicle key: battery compartment cover

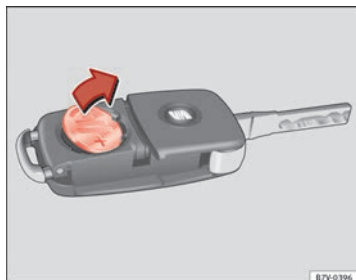


Fig. 16 Vehicle key: removing the battery

SEAT recommend having the batteries changed in a Specialised workshop.

The battery is located to the rear of the vehicle key, under a cover.

Changing the battery

- Unfold the key shaft ⇒ page 29.
- Remove the cover from the back of the vehicle key ⇒ Fig. 15 in the direction of the arrow ⇒ ①.
- Extract the battery from the compartment using a suitable thin object ⇒ Fig. 16.
- Place the new battery in the compartment, pressing as shown ⇒ Fig. 16 in the opposite direction to the arrow ⇒ ②.
- Fit the battery compartment cover, pressing in the direction of the arrow as shown ⇒ Fig. 15 until it clicks into place.



CAUTION

- If the battery is not changed correctly, the vehicle key may be damaged.
- Use of unsuitable batteries may damage the vehicle key. For this reason, always replace the dead battery with another of the same voltage, size and specifications.
- When fitting the battery, check that the polarity is correct.



For the sake of the environment

Please dispose of your used batteries correctly and with respect for the environment. ■

To synchronise the vehicle key

If the button ④ is pressed frequently outside of the vehicle range, it is possible that the vehicle can no longer be locked or unlocked using the key. In this case, synchronise the vehicle key once more as follows:

- Unfold the key shaft ⇒ page 29.
- Press the button ④ on the vehicle key. For this, you must remain next to the vehicle. ▶

- Open the vehicle within one minute using the key shift.
- Turn on the ignition using the vehicle key. The key has been synchronised.
- If necessary, fit the cap. ■

Central locking* and locking system

Introduction

Central locking functions correctly when all the doors and the rear lid are correctly shut. If the driver door is open, the vehicle *cannot* be locked with the key.

The battery of a vehicle left unlocked during a long period (for instance, in a private garage) may run down and fail to start the motor.

Additional information and warnings:

- Exterior detail ⇒ page 6
- Vehicle key set ⇒ page 28
- Doors ⇒ page 38
- Rear lid ⇒ page 40
- Electric windows ⇒ page 43
- Emergency locking and unlocking ⇒ page 243

WARNING

The incorrect use of the central locking system may cause serious injuries.

- The central locking system will lock all doors. A vehicle locked from the inside can prevent any non-authorized individual from opening the doors and accessing the vehicle. Nevertheless, in case of emergency or accident, locked doors will complicate access to the passenger compartment to help the passengers.
- Never leave children or disabled people alone in the vehicle. The central locking button can be used to lock all the doors from within. Therefore, passengers will be locked inside the vehicle. Individuals locked in the vehicle can be exposed to very high or very low temperatures.

WARNING (Continued)

- Depending on the time of the year, temperatures inside a locked and closed vehicle can be extremely high or extremely low resulting in serious injuries and illness or even death, particularly for young children.
- Never leave individuals locked in a closed and locked vehicle. In case of emergency, they may not be able to exit the vehicle by themselves or get help.

Description of the central locking system

The central locking system allows all doors and the rear lid to be locked and unlocked centrally.


- From outside, using the vehicle key.
- From inside, by pushing the central locking button ⇒ page 36.

The central locking system can be activated or deactivated at a specialised workshop.

In case of a vehicle key fault or central locking system fault, all doors can be locked or unlocked manually.

Locking the vehicle after the airbags have been deployed

If the airbags are deployed due to an accident, the vehicle will be automatically and completely unlocked. Depending on the amount of damage, the vehicle can be locked following an accident in the following ways: ▶

Function	Necessary operations
Lock the vehicle, by pushing the central locking button:	<ul style="list-style-type: none"> – Turn off the ignition and turn it on again. – Push the central locking button .
Use the key to lock the vehicle:	<ul style="list-style-type: none"> – Turn off the ignition and turn it on again. OR: Remove the key from the ignition. – Open any door just once. – Lock the vehicle with the key.

**Note**

If the buttons of the vehicle key are pressed ⇒ page 28 or one of the central locking buttons ⇒ Fig. 19 is pressed repeatedly in short succession, the central locking briefly disconnects as protection against overloading. In this case, the vehicle remains unlocked for about. 30 seconds. If no doors or the rear lid are opened during this time, the vehicle will subsequently become locked automatically.

Locking and unlocking the vehicle from the exterior







Fig. 17 Buttons on the vehicle key




Fig. 18 Vehicle mechanical key

Central locking

Function	Handling the buttons on the vehicle ⇒ Fig. 17	Handling the vehicle key ⇒ Fig. 17 in the lock cylinder or with the vehicle mechanical key ⇒ Fig. 18.
Unlocking the vehicle.	Press button  .	Insert the vehicle key into the lock cylinder of the driver door and turn the key in an anticlockwise direction .
Locking the vehicle.	Press button  .	Insert the vehicle key into the lock cylinder of the driver door and turn the key in a clockwise direction .

Function	Handling the buttons on the vehicle ⇒ Fig. 17	Handling the vehicle key ⇒ Fig. 17 in the lock cylinder or with the vehicle mechanical key ⇒ Fig. 18.
Unlocking the rear lid.	Press button  .	Insert the vehicle key into the lock cylinder of the driver door and turn the key in an anticlockwise direction .
Locking the rear lid.	Press button  .	Insert the vehicle key into the lock cylinder of the driver door and turn the key in a clockwise direction .

Attention: Depending on the operating of the central locking set by the Specialised workshop, in order to unlock all the doors and the rear lid, press the button  twice.

The vehicle key only locks and unlocks the vehicle if it is within range of the vehicle and if the battery has enough power.

- Upon locking the vehicle, all turn signals will flash *once* in confirmation.
- Upon unlocking the vehicle, all turn signals will flash *twice* in confirmation.

If the turn signals *do not* flash in confirmation, at least one of the doors or the rear lid has been left unlocked.

If the driver door is open, the vehicle cannot be locked with the key. If you unlock the vehicle without opening any doors or the rear lid, it will lock again automatically after a few seconds. This function prevents the vehicle from remaining unlocked if the unlocking button is pressed by mistake.

Mechanical locking

Function	Handling the vehicle mechanical key ⇒ Fig. 18 in the lock cylinder.
Locking the driver door manually.	To <i>unlock</i> , insert the vehicle key into the lock cylinder of the driver door and turn the key in an anticlockwise direction .
	To <i>lock</i> , insert the vehicle key into the lock cylinder of the driver door and turn the key in a clockwise direction .
Locking and unlocking the rear lid.	To <i>unlock</i> , insert the vehicle key into the lock cylinder of the driver door and turn the key in an anticlockwise direction .
	To <i>lock</i> , insert the vehicle key into the lock cylinder of the driver door and turn the key in a clockwise direction .

If the driver door is open, the vehicle cannot be locked with the vehicle key. ■

Locking and unlocking the vehicle from the inside



Fig. 19 In the driver door: central locking button

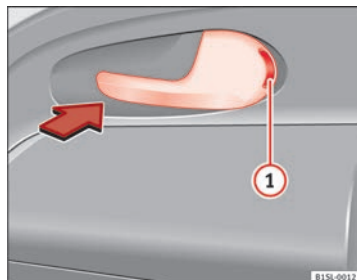




Fig. 20 In the passenger door: Door handle for mechanical locking

Central locking

Push the button ⇒ Fig. 19:

- | | |
|---|------------------------|
|  | Unlocking the vehicle. |
|  | Locking the vehicle. |

The central locking button is still operative when the ignition is switched off.

If the vehicle has been locked with the vehicle key, the central locking button does not operate.

Please note the following when you use the central locking button to lock your vehicle:

- The deadlock **will not** activate ⇒ page 37.
- It will not be possible to open the doors or the rear lid from the *outside*, when stopped at traffic lights for example.
- The doors can be opened and unlocked individually from the inside by pulling the inside door handle. If necessary, pull the door release lever twice.
- The driver door cannot be locked when it is still open. This avoids locking the vehicle key inside the vehicle when there is nobody inside.

Mechanical locking

The doors are locked by pressing the door lever, so that the red mark becomes visible ⇒ Fig. 20 ①.




To unlock a door, pull its corresponding door lever.


If the vehicle becomes locked, take note of the following:

- The deadlock **will not** activate ⇒ page 37.
- It will not be possible to open the doors from the *outside*, when stopped at traffic lights for example. ▶

- The doors can be opened and unlocked individually from the inside by pulling the inside door handle.
- The driver door cannot be locked using the central locking system when it is still open. This avoids locking the vehicle key inside the vehicle when there is nobody inside.

Deadlock*

Function	Necessary operations
Locks the vehicle with the deadlock.	Press the  button <i>once</i> on the vehicle key.
Locks the vehicle without the deadlock.	Press the  button <i>twice</i> on the vehicle key. Press the central locking button  on the driver door once.

When the vehicle is locked, the deadlock deactivates the door handles, making the vehicle difficult to open. The doors cannot be opened from inside ⇒ .

Upon switching off the ignition, the deadlock switched on warning will appear on the instrument panel display (**deadlock** or **SAFELOCK**).

When the deadlock is switched off:

- The vehicle can be opened and unlocked from the inside using an inside door handle.

Control lamp on the driver door

When the vehicle is locked:	Meaning
The red LED flashes for approximately 2 seconds at short intervals and then more slowly.	The deadlock is switched on.
The red LED flashes for about two seconds then turns off. After 30 seconds, the LED flashes again.	The deadlock is switched off.
The red LED flashes for about two seconds at short intervals. Subsequently, the light will remain switched on for about 30 seconds.	There is a fault in the locking system. Contact a Specialised workshop.



WARNING

Careless use of the deadlock can cause serious injury.

- **Never leave anybody inside the vehicle if this is locked using the key. When the deadlock is activated, doors cannot be opened from the inside!**
- **When the doors are locked, it is difficult to get to passengers in the interior in case of an emergency. Passengers could remain trapped inside in case of emergency.**

Doors

Introduction

Additional information and warnings:

- Vehicle key set ⇒ page 28
- Central locking and locking system ⇒ page 33
- Emergency locking and unlocking ⇒ page 243

WARNING

If a door is not correctly closed, it could open unexpectedly when driving and cause serious injuries.

- Always stop immediately and close the door.
- When closing, ensure that the door has closed correctly. A closed door should be flush with the corresponding parts of the bodywork.
- Open and close doors only when nobody is in the way of the door.

WARNING

A door held open by its retainer could be blown closed by the wind or closed if the vehicle is on a hill causing injury.

- When opening and closing doors, always use the door handle.

Note

On the display of the SEAT Portable System (supplied by SEAT), ⇒ page 222 can be seen if at least one vehicle door has been left open or is not correctly closed.

Childproof lock

The childproof lock prevents the rear doors from being opened from the inside. This system prevents minors from opening a door accidentally while the vehicle is running.



Fig. 21 Childproof lock on the left hand side door

This function is independent of the vehicle electronic opening and locking systems. It only affects rear doors. It can only be activated and deactivated manually, as described below:

Activating the childproof lock

- Unlock the vehicle and open the door in which you wish to activate the childproof lock.
- With the door open, rotate the groove in the door using the ignition key, anticlockwise for the left hand side doors ⇒ Fig. 21 and clockwise for the right hand side doors.

Deactivating the childproof lock

- Unlock the vehicle and open the door whose childproof lock you want to deactivate.
- With the door open, rotate the groove in the door using the ignition key, anticlockwise for the right hand side doors and clockwise for the left hand side doors ⇒ Fig. 21.

Once the childproof lock is activated, the door can only be opened from the outside. The childproof lock can be activated and deactivated by inserting the key in the groove when the door is open, as described above. ■

Rear lid

Introduction

Additional information and warnings:

- Exterior detail ⇒ page 6
- Central locking ⇒ page 33
- Transporting ⇒ page 97
- Emergency locking and unlocking ⇒ page 243



WARNING

Careless and unsuitable locking, opening and closing of the rear lid can cause accidents and serious injury.

- Open and close the rear lid only when nobody is in the way.
- Do not close the rear lid by pushing it down with your hand on the rear window. The rear window could break and cause injury.
- Ensure the rear lid is closed and locked correctly after closing, otherwise, it may open unexpectedly while driving. A closed rear lid should be flush with the corresponding parts of the bodywork.
- Always keep the rear lid closed while driving to avoid toxic gases entering the interior.
- Do not open the rear lid when there is a load installed, for example a carrier system. Likewise, the rear lid cannot be opened when a load is attached to it, for example bicycles. An open rear lid could close itself if there is an additional weight on it. If necessary, press down on the rear lid and remove the load.
- Close and lock both the rear lid and all the other doors when you are not using the vehicle. Ensure that nobody remains inside the vehicle.



WARNING (Continued)

- Never allow children to play inside or around the vehicle without supervision, especially if the rear lid is open. Children could enter the luggage compartment, close the rear lid and become trapped. Depending on the time of the year, temperatures inside a locked and closed vehicle can be extremely high or extremely low resulting in serious injuries and illness or even death, particularly for young children.
- Never leave children or disabled people alone in the vehicle. If the vehicle key or the central locking button is used, they may be locked in the vehicle.



CAUTION

Before opening the rear lid, ensure that there is sufficient free space to open and close it, for example if you are in a garage.



Note

On the display of the Portable Navigation System (supplied by SEAT) ⇒ page 222 can be seen if the rear lid has been left open or is not correctly shut. ■



Opening the rear lid



Fig. 22 On the vehicle key: Button to unlock and open the rear lid

If there are bicycles attached to a carrier situated on the rear lid, in some cases, it may not automatically open ⇒ ⚠. Remove the load from the carrier and support the open rear lid.

Opening with central locking

- Press the button  on the vehicle key ⇒ Fig. 22 for about one second to unlock the rear lid.
- **ALTERNATIVELY:** Press the button  on the vehicle key until the rear lid opens automatically several centimetres.
- Opening the rear lid with the button.

Opening with the vehicle mechanical key

- Insert the vehicle key into the lock cylinder of the driver door and turn the key **in an anticlockwise direction** ⇒ page 33.
- Opening the rear lid with the button.

WARNING

Unsuitable or careless unlocking and opening of the rear lid could cause serious injuries.

- If there is a loaded luggage carrier on the rear lid, it could be unlocked or open but not recognised as such. An unlocked or open rear lid could open unexpectedly while driving.

Note

At outside temperatures of less than 0 °C (+32 °F), the pressurised gas struts cannot always automatically lift the tailgate. In this case, open the rear lid manually.

Closing the rear lid

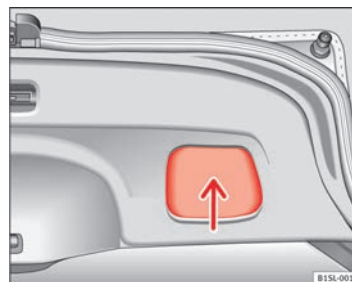


Fig. 23 Rear lid open: hand grip


Closing the rear lid

- Grab the handgrip inside the rear lid ⇒ Fig. 23 (arrow).
- Push the rear lid downwards until it locks into place in the lock.
- Ensure that it is correctly closed by pulling on it firmly.

Locking the rear lid with central locking*

If the vehicle is unlocked and no doors or the rear lid are opened during about 30 seconds, it will automatically lock again. This function prevents the vehicle from remaining unlocked if the unlocking button is pressed by mistake.

Locking is only possible when the rear lid is correctly and fully closed.

- The rear lid is also locked by a central locking.
- If the vehicle rear lid is locked or unlocked using the  button, when it is closed once more it will lock automatically.
- A closed but not locked rear lid will lock automatically at a speed above about 9 km/h (6 mph).

Locking the rear lid with the vehicle mechanical key

Locking is only possible when the rear lid is correctly and fully closed.

- Insert the vehicle key into the lock cylinder of the driver door and turn the key **in a clockwise direction** ⇒ page 33.



Note

Before closing the rear lid, make sure that the key has not been left inside the boot. ■



WARNING

Unsuitable or careless closing and locking of the rear lid could cause serious injuries.

- **Never leave the vehicle unattended, and never allow children to play inside or around the vehicle without supervision, especially if the rear lid is open. Children could enter the luggage compartment, close the rear lid and become trapped. A locked vehicle can be subjected to extremely high and low temperatures, depending on the time of year, thus causing serious injuries/illness and even death.**

Windows

Introduction

Additional information and warnings:

- SEAT information system ⇒ page 22
- Central locking and locking system ⇒ page 33

WARNING

Careless use of the electric windows can cause serious injury.

- Only operate the electric windows when nobody is in the way.
- Never leave children or disabled people alone in the vehicle if the doors are to be locked. The windows cannot be opened in case of an emergency.
- Always take all the keys with you whenever you leave the vehicle. After turning off the ignition, the windows can be opened and closed for a short time using the buttons on the door as long as the driver door or passenger side door is not open.

CAUTION



When the windows are open, rain can enter into the vehicle, dampening the interior equipment and causing damage to the vehicle. ■

Opening and closing the electric windows



Fig. 24 In the driver door: electric windows button

Opening and closing the windows

Function	Necessary operations
Opening:	Press button  .
Closing:	Push the button  .

Side-opening rear windows

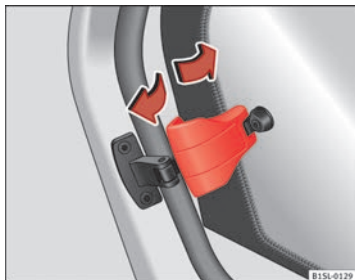


Fig. 25 Lever to open and close the rear window

Opening

Pull the release lever in the direction of the arrow and press outwards until the lever engages.

Closing

Pull the release lever in the direction of the arrow and then press the lever backwards until it engages.

Opening and closing the sliding/tilting electric panoramic sunroof

Introduction

Additional information and warnings:

- Central locking and locking system ⇒ page 33
- Roof carrier ⇒ page 104



WARNING

If the sliding/tilting electric panoramic sunroof is used negligently or without paying due attention, it can cause serious injury.

- The sliding/tilting sunroof should only be opened or closed when no person remains in the way of it.
- After switching off, it is still possible to open or close the sliding/tilting sunroof during a short space of time provided that neither the driver nor passenger door is opened.



CAUTION

- To prevent damage, when there are winter temperatures any ice or snow that there may be on the roof of the vehicle must be removed before opening or raising the sliding/tilting electric panoramic sunroof.
- Before leaving the vehicle or in the case of heavy rain, the sliding/tilting sunroof must always be closed. With the sliding/tilting sunroof open or raised, water can enter the passenger compartment and can cause considerable damage to the electrical system. As a result, other damage can occur in the vehicle.
- In the case of heavy rain, if the sliding/tilting sunroof is open, the interior equipment of the vehicle may get wet, destroying the seat heating and damaging the electrical system of the vehicle.

i Note

- Leaves and other loose objects that land in the guides of the sliding/tilting sunroof should be removed periodically by hand or using a vacuum cleaner.
- If the sliding/tilting sunroof does not work correctly, the anti-trap function will not work either. In this case, you should take the vehicle to a specialised workshop.

Opening and closing the sliding/tilting electric panoramic sunroof

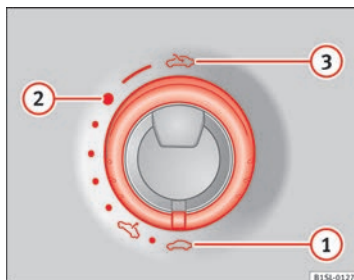


Fig. 26 In the interior roof: turn the knob to open and close

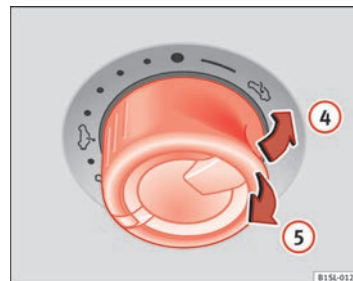


Fig. 27 In the interior roof: turn the knob to raise and to close the sunroof

To raise the sliding/tilting sunroof, the knob must be in the basic position ①.

Function	⇒ Fig. 26 or ⇒ Fig. 27	Action
To open the sliding sunroof completely:	③	turn the knob beyond position 2 and hold it in that position until the sunroof reaches the required position.
Put the sliding sunroof in convenience position:	②	Turn the knob to the required position.
To set the intermediate position:	② to ①	
To close the sliding sunroof completely:	①	

Function	⇒ Fig. 26 or ⇒ Fig. 27	Action
To raise the tilting sunroof completely:	④	briefly press the rear part of the knob.
To stop automatic operation:	④ or ⑤	Press or pull the knob again briefly.
To close completely:	⑤	briefly pull the rear part of the knob.

The sliding/tilting sunroof only works when switched on. After switching off, it is still possible to open or close the sliding/tilting sunroof during a short space of time provided that neither the driver nor passenger door is opened.

All operations are interrupted when the rotary knob is actuated.

If it were not possible to close the sliding/tilting sunroof electrically, it would need to be closed manually. It is not possible to do an emergency close of the sliding/tilting sunroof without removing components of the vehicle. In such a case, obtain professional assistance.

Sliding blind

With the roof grab handle situated in the rear part of the roof opening, it is possible to move the sliding blind to the required position.



Note

The convenience position permits sufficient ventilation with a level of sound produced by low wind. ■

Anti-trap function of the sliding/tilting electric panoramic sunroof

The anti-trap function can reduce the risk of injury when closing the sliding/tilting electric panoramic sunroof ⇒ . If the sliding/tilting sunroof encounters resistance or an obstacle when closing, it will immediately reopen.

- Check why the sliding/tilting sunroof has not closed.
- Try to close it again.
- If it is still not possible to close it due to an obstacle or resistance, it will remain in the corresponding position. Close it without the anti-trap function.

Closing the sliding/tilting electric panoramic sunroof without the anti-trap function

- Before approx. 5 seconds have passed since the activation of the anti-trap function, pull the knob ⇒ Fig. 27 until the sliding/tilting sunroof is completely closed.
- **As such, the sliding/tilting sunroof will close without the anti-trap function!**
- If the sunroof still cannot be closed, visit a specialised workshop.

If the knob is released during the closing operation, the sliding/tilting electric panoramic sunroof opens automatically.



WARNING

Closing the sliding/tilting electric panoramic sunroof without the anti-trap function can result in serious injury.

- **The sliding/tilting sunroof should always be closed carefully.** ►

 **WARNING (Continued)**

- No person should ever remain in the way of the sliding/tilting sunroof, especially when closing without the anti-trap function.
- The anti-trap function does not prevent fingers or other parts of the body from becoming trapped against the roof frame and injuries occurring.

Ensuring you are correctly and safely seated

Adjusting the seat position

Introduction

Number of seats

The vehicle has a total of 4 seats: 2 front seats and 2 rear seats. Each seat is equipped with a seat belt.

Additional information and warnings:

- Seat functions ⇒ page 55
- Seat belts ⇒ page 57
- Airbag system ⇒ page 67
- Child seats (accessories) ⇒ page 76



WARNING

An incorrect sitting position in the vehicle can lead to severe injuries or death in the event of sudden braking or manoeuvres, collision or accidents or if the airbag deploys.

- Before the vehicle moves, assume the proper sitting position and maintain it throughout the trip. This also includes fastening the seat belt.
- Never transport more people than there are seats with a seat belt available in the vehicle.



WARNING (Continued)

- Children must always be protected with an approved child restraint system suited to their height and weight ⇒ page 76, ⇒ page 67.
- Always keep your feet in the footwell while the vehicle is in motion. Never, for example, put your feet on the surface of a seat or on the dash panel and never put them out of a window. Otherwise the airbag and seat belt offer insufficient protection and the risk of injury in the event of an accident is increased.



WARNING

Before every trip, adjust the seat, the seat belt and the head restraints and instruct your passengers to fasten their seat belts properly.

- Move the front passenger seat back as far as possible.
- Adjust the driver seat so that there is at least 25 cm distance between your chest and the hub of the steering wheel. Adjust the driver seat so that you are able to press the accelerator, brake and clutch pedals to the floor with your knees slightly angled and that the distance between your knees and the dash panel is at least 10 cm. If your physical constitution prevents you from meeting these requirements, contact a Specialised workshop to make any modifications required.
- Never drive with the backrest tilted far back. The further the backrests are tilted to the rear, the greater the risk of injury due to incorrect positioning of the belt web or to the incorrect sitting position.
- Never drive with the backrest tilted forwards. Should a front airbag deploy, it could throw the backrest backwards and injure the passengers of the rear seats.
- Sit as far away as possible from the steering wheel and the dash panel.

⚠ WARNING (Continued)

- **Keep your back straight and resting completely against the backrest and the front seats correctly adjusted. Never place any part of your body in the area of the airbag or very close to it.**
- **If passengers on the rear seats are not sitting in an upright position, the risk of severe injury due to incorrect positioning of the belt web increases.**

⚠ WARNING

Incorrect seat adjustment may lead to accidents and severe injuries.

- **Only adjust the seats when the vehicle is stationary, as the seats could move unexpectedly while the vehicle is in motion and you could lose control of the vehicle. Furthermore, an incorrect position is adopted when adjusting the seat.**
- **Only adjust the height, backrest and forwards or backwards position of the seat when there is nobody in the seat adjustment area.**
- **There must be no objects blocking the front seat adjustment area.**

Danger of injuries due to an incorrect sitting position

If the seat belts are worn incorrectly or not at all, the risk of severe or fatal injuries increases. Seat belts can provide optimal protection only if the belt web is properly worn. The seat belt cannot offer its full protection if the belt web is not positioned correctly. This could result in severe and even fatal injuries. The risk of severe or fatal injuries is especially increased when a deploying airbag strikes an occupant who has assumed an incorrect sitting position. The driver is responsible for all passengers in the vehicle, particularly children.

The following list shows just some examples of incorrect sitting positions which can be dangerous to all occupants.

When the vehicle is in motion:

- Never stand in the vehicle.
- Never stand on the seats.
- Never kneel on the seats.
- Never tilt your backrest too far to the rear.
- Never lean against the dash panel.
- Never lie on the rear seats.
- Never sit on the front edge of a seat.
- Never sit sideways.
- Never lean out of a window.
- Never put your feet out of a window.
- Never put your feet on the dash panel.
- Never put your feet on the surface of a seat or backrest.
- Never travel in a footwell.
- Never travel on a seat without wearing the seat belt.
- Never carry any person in the luggage compartment.

⚠ WARNING

Every incorrect sitting position increases the risk of severe or fatal injuries in the event of accidents or sudden braking or manoeuvres.

- **All vehicle occupants must assume the proper sitting position and be properly belted in while travelling.**
- **Occupants in incorrect sitting positions, not wearing their seat belt or too close to the airbag run the risk of suffering severe or fatal injuries, particularly if the airbag deploys and hits an occupant sitting in an incorrect position.**

Correct sitting position

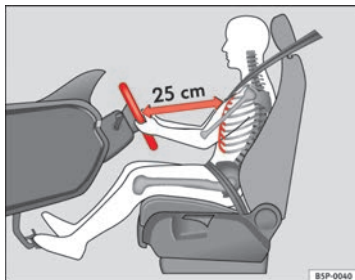


Fig. 28 The proper distance between driver and steering wheel

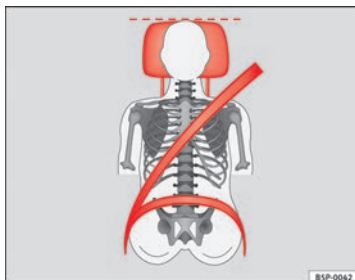


Fig. 29 Correct seat belt web and head restraint positions

The correct sitting positions for the driver and passengers are shown below.

If your physical constitution prevents you from maintaining the correct sitting position, contact a Specialised workshop for help with any special devices. The seat belt and airbag can only provide optimum protection if a cor-

rect sitting position is adopted. SEAT recommends visiting a Technical Service.

For your own safety and to reduce the risk of injury in the event of an accident or sudden braking or manoeuvre, SEAT recommend the following positions:

Valid for the driver:

- Adjust the backrest to an upright position so that your back rests completely against it.
- Adjust the seat so that there is a distance of at least 25 cm between the steering wheel and your chest ⇒ Fig. 28 and so that you can hold the steering wheel with both hands on the outside of the ring at the 9 o'clock and 3 o'clock positions with your arms slightly bent.
- The adjusted steering wheel must face your chest and not your face.
- Adjust the driver seat forwards or backwards so that you are able to press the accelerator, brake and clutch pedals to the floor with your knees slightly angled and the distance between your knees and the dash panel is at least 10 cm ⇒ Fig. 28.
- Adjust the height of the driver seat so that you can easily reach the top of the steering wheel.
- Keep both feet in the footwell so that you have the vehicle under control at all times.
- Adjust and fasten your seat belt correctly ⇒ page 57.

Valid for the passenger:

- Adjust the backrest to an upright position so that your back rests completely against it.
- Move the front passenger seat back as far as possible for optimum protection should the airbag deploy.
- Always keep your feet in the footwell while the vehicle is in motion.
- Adjust and fasten your seat belt correctly ⇒ page 57. ▶

Valid for the passengers in the rear section:

- Adjust the head restraint so that its upper edge is at the same level as the top of your head, or as close as possible to the same level as the top of your head and under no circumstances below eye level. Keep the back of your neck as close as possible to the head restraint ⇒ Fig. 28 and ⇒ Fig. 29.
- Short people must lower the head restraint to the first anchorage position, even if your head is below its upper edge.
- Tall people must raise the head restraint completely.
- Always keep your feet in the footwell while the vehicle is in motion.
- Adjust and fasten your seat belt correctly ⇒ page 57.

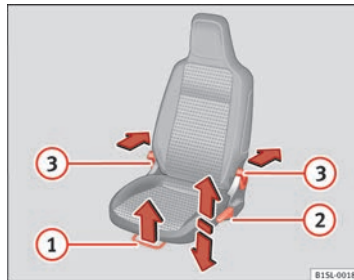
Controls on the front seat

Fig. 30 Front left seat controls

The controls are mirrored for the front right-hand seat.

The front seat head restraints are integrated in the backrests and adjusting them is not possible.

Fig. 30	Function	Necessary operations
①	Moving the head restraint backwards or forwards.	Pull the lever and move the seat forwards. The front seat must be engaged when the lever is released!
②	Adjusting the seat height.	Pull the lever up or push down (several times if necessary) from its home position. <i>Adjust:</i> Pull the lever and adjust the backrest seat angle until you reach the desired position. The backrest must be engaged. <i>To fold:</i> Pull the lever and fold the backrest. At the same time, move the seat forward. <i>To tilt open:</i> Move the seat back until the catch engages. Pull the lever and tilt open the backrest. The backrest must engage in the upright position.
③	3 doors: Easy Entry + adjustable seat angle function. 5 doors: only adjustable seat angle function.	

Adjust the rear head restraints

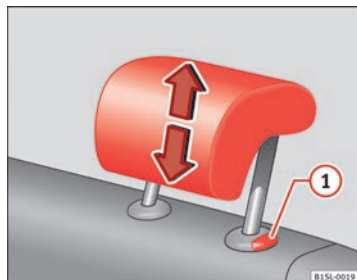


Fig. 31 Adjusting the rear head restraints

All seats are equipped with a head restraint.

The front seat head restraints are integrated in the backrests and adjusting them is not possible.

Adjusting height

- Push the head restraint up or down in the direction of the arrow with the button pressed ⇒ Fig. 31 ① ⇒ ⚠.
- The head restraint must engage securely in position.

Correct adjustment of head restraints

Adjust the head restraint so that its upper edge is at the same level as the top of your head, or as close as possible to the same level as the top of your head and under no circumstances below eye level. Keep the back of your neck as close as possible to the head restraint.

Adjusting the head restraint for short people

Set the head restraint in the first anchorage position, even if your head is below its upper edge. When the head restraint is at its lowest, it is possible that a small gap remains between it and the backrest.

Adjusting the head restraint for tall people

Raise the head restraint completely.



WARNING

Travelling with the head restraints removed or improperly adjusted increases the risk of severe or fatal injuries in the event of accidents and sudden braking or manoeuvres.

- Always fit and adjust the head restraint properly whenever a person is occupying a seat.
- All occupants must correctly adjust the head restraint according to their height to reduce the risk of back injuries in the event of an accident. The upper edge of the head restraint must be as close as possible to the same level as the top of your head and under no circumstances below eye level. Keep the back of your neck as close as possible to the head restraint.
- Never adjust the head restraint while the vehicle is in motion. ■

Removing and installing the rear head restraints

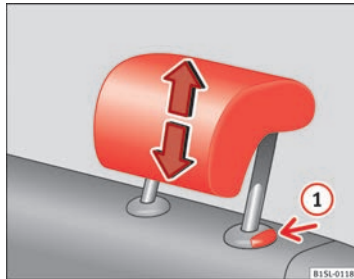





Fig. 32 Removing the rear head restraint

The rear seats are equipped with a head restraint.

Removing the rear head restraint.

- Unlock the rear seat bench backrest and fold it forward ⇒ page 100.
- Push the head restraint up as far as it will go ⇒ .
- Pull the head restraint out of the fitting without releasing the button ⇒ Fig. 32 .
- Fold the backrest of the rear seat bench backwards until it is engaged.
- Safely store the removed head restraints.

Removing the rear head restraint.

- Unlock the rear seat bench backrest and fold it forward ⇒ page 100.
- Correctly insert the head restraint into the guides on the backrest.
- Push the head restraint down as far as it will go while pressing button .
- Fold the backrest of the rear seat bench backwards until it is engaged.
- Adjust the head restraint to the correct position ⇒ page 52.

WARNING

Travelling with the head restraints removed or improperly adjusted increases the risk of severe or fatal injuries in the event of accidents and sudden braking or manoeuvres.

- Always fit and adjust the head restraint properly whenever a person is occupying a seat.
- Refit any removed head restraints immediately so that passengers are properly protected.

CAUTION

On removing and fitting the head restraint, make sure the head restraint does not hit the interior roof of the vehicle or the backrest of the front seat. This could damage the interior roof and other parts of the vehicle.

Adjusting the steering wheel position

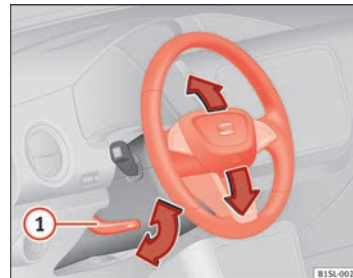


Fig. 33 Mechanical steering wheel adjustment

Adjust the steering wheel before your trip and only when the vehicle is stationary.

- Push the lever ⇒ Fig. 33 ① downwards.
- Adjust the steering wheel so that you can hold onto the steering wheel with both hands on the outside of the ring at the 9 o'clock and 3 o'clock positions and your arms slightly bent.
- Push the lever firmly upwards until it is flush to the steering column ⇒ ⚠.

Adjust the correct distance between the driver and the steering wheel ⇒ Fig. 28 using the controls on the driver seat ⇒ page 51.

**WARNING**

Incorrect use of the steering wheel adjustment function and an incorrect adjustment of the steering wheel can result in severe or fatal injury.

- After adjusting the steering column, push the lever ⇒ Fig. 33 ① firmly upwards to ensure the steering wheel does not accidentally change position while driving.
- Never adjust the steering wheel while the vehicle is in motion. If you need to adjust the steering wheel while the vehicle is in motion, stop safely and make the proper adjustment.
- The adjusted steering wheel should be facing your chest and not your face so as not to hinder the driver's frontal airbag protection in the event of an accident.
- When driving, always hold the steering wheel with both hands on the outside of the ring at the 9 o'clock and 3 o'clock positions to reduce injuries when the driver's frontal airbag deploys.
- Never hold the steering wheel at the 12 o'clock position or in any other manner (e.g. in the centre of the steering wheel). In such cases, if the driver's airbag deploys, you may sustain injuries to your arms, hands and head.

Seat functions

Introduction

Additional information and warnings:

- Adjust the seat position ⇒ page 48
- Seat belts ⇒ page 57
- Airbag system ⇒ page 67
- Child seats (accessories) ⇒ page 76
- Exterior mirrors ⇒ page 95

WARNING

Inappropriate use of the seat functions can cause severe injuries.

- Assume the proper sitting position before your trip and remain in it throughout. This also applies to the other occupants.
- Keep hands, fingers, feet and other limbs away from the seat operating and adjustment radius.




Seat heating*



Fig. 34 In the centre console: Front seats heating switch

The front seat cushions can be heated electrically when the ignition is switched on.

Switch off seat heating if there is nobody in the seat.

Function	Action ⇒ Fig. 34
To switch on:	Press button  . Seat heating is switched on fully. All warning signals light up.
Adjusting the heating output:	Press the button  again to adjust the desired heat.
To switch off:	Keep pressing button  until all of the lights are switched off.

**WARNING**

People whose pain and temperature threshold has been affected by some kind of medicine, paraplegia or chronic illness (e.g. diabetes) may sustain burns to the back, buttocks and legs from use of the seat heating that may lead to a long healing process or that may never completely heal. Seek medical advice if you have doubts regarding your health.

- People with a limit pain and temperature threshold must never use seat heating.

**CAUTION**

- To avoid damaging the heating elements of the seat heating, please do not kneel on the seat or apply sharp pressure at a single point to the seat cushion and backrest.
- Liquids, sharp objects and insulating materials on the seat could damage the seat heating.
- In the event of smells, switch off the seat heating immediately and have the unit inspected by a Specialised workshop.

**For the sake of the environment**

The seat heating should remain on only when needed. Otherwise, it is an unnecessary fuel consumption. ■

Seat belts

Introduction

Check the condition of all the seat belts at regular intervals. If you notice that the belt webbing, fittings, retractor mechanism or buckle of any of the belts is damaged, the belt must be replaced immediately by a Specialised workshop ⇒ ⚠. The Specialised workshop must use the appropriate spare parts corresponding to the vehicle, the equipment and the model year. SEAT recommends visiting a Technical Service.

Additional information and warnings:

- Adjust the seat position ⇒ page 48
- Airbag system ⇒ page 67
- Child seats (accessories) ⇒ page 76
- Accessories, parts replacement, repairs and modifications ⇒ page 222

⚠ WARNING

Unbuckled or badly buckled seat belts increase the risk of severe or even fatal injuries. The seat belt cannot offer its full protection if it is not fastened and used correctly.

- Seats belts are the most effective ways of reducing the risk of sustaining severe or fatal injuries in the event of an accident. Correctly fasten seat belts when the vehicle is in motion to protect the driver and all vehicle occupants.
- Before each trip, every occupant in the vehicle occupants must sit properly, correctly fasten the seat belt belonging to his or her seat and keep it fastened throughout the trip. This also applies to other occupants when driving in town.

⚠ WARNING (Continued)

- When travelling, children must be secured in the vehicle with a child restraint system suitable for their weight and height and with the seat belts correctly fastened ⇒ page 76.
- Instruct your passengers to fasten their seat belts properly before driving off.
- Insert the latch plate into the buckle for the appropriate seat and ensure it is engaged. Using the latch plate in the buckle of another seat will not protect you properly and may cause severe injuries.
- Do not allow liquids or foreign bodies to enter the buckle fastenings. This could damage the buckles and seat belts.
- Never unbuckle your seat belt when the vehicle is moving.
- Never allow more than one passenger to share the same seat belt.
- Never hold children or babies on your lap sharing the same seat belt.
- Loose, bulky clothing (such as a jacket) impairs the proper fit and function of the seat belt.

⚠ WARNING

It is extremely dangerous to drive using damaged seat belts and could result in serious injury or loss of life.

- Avoid damaging the seat belt by jamming it in the door or the seat mechanism.
- If the fabric or other parts of the seat belt are damaged, the seat belts could break in the event of an accident or sudden braking.
- Always have damaged seatbelts replaced immediately by seat belts approved for the vehicle in question by SEAT. Seat belts which have been worn in an accident and stretched must be replaced by a Specialised workshop. Renewal may be necessary even if there is no apparent damage. The belt anchor points should also be checked.
- Never attempt to repair, modify or remove a seat belt yourself. All repairs to seat belts, retractors and buckles must be carried out by a Specialised workshop.





Warning lamp




Fig. 35 Warning lamp on the instrument panel




Fig. 36 Indication of seat belt status in the rear seats on the instrument panel display


Lights up or flashes	Possible cause	Solution
	On the instrument panel: Driver's seat belt not fastened or front passenger seat belt not fastened if the front passenger's seat is occupied.	Fasten seat belts!
	On the instrument panel: Objects on the front passenger seat.	Remove any objects from the front passenger seat and store them safely.
	Instrument panel display: A passenger in the rear seats has not fastened their seat belt, if the seat is occupied.*	Fasten seat belts!
	On the instrument panel display: A passenger in the rear seats has fastened their seat belt, if the seat is occupied.*	

Several warning and control lamps light up for a few seconds when the ignition is switched on while a test of the function is being carried out. They will switch off after a few seconds.

An audible warning will be heard if the seat belts are not fastened as the vehicle drives off and reaches a speed of more than 25 km/h (15 mph) or if the seat belts are unfastened while the vehicle is in motion. The seat belt warning lamp  will also flash.

The warning lamp  does not switch off until the driver and front passenger fasten their seat belts while the ignition is switched on.

Seat belt status display for rear seats

The seat belt status display on the instrument panel display informs the driver, when the ignition is switched on, whether any passengers in the rear seats have fastened their seat belts. The symbol  indicates that the passenger in this seat has fastened "his or her" seat belt ⇒ Fig. 36. ▶

The seat belt status is displayed for around 30 seconds when a seat belt in the rear seats is fastened or unfastened. You can switch off this display by pressing the **(0.0 / SET)** button.

The seat belt status flashes for a maximum of 30 seconds when a seat belt in the rear seats is unfastened while the vehicle is in motion. An audible warning will also be heard if the vehicle is travelling at over 25 km/h (15 mph).

WARNING

Unbuckled or badly buckled seat belts increase the risk of severe or even fatal injuries. The optimal protection from seat belts can be achieved only if you use them properly.

Frontal collisions and the laws of physics

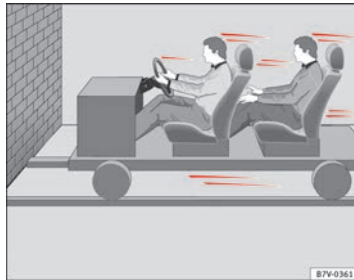


Fig. 37 Vehicle about to hit a wall: the occupants are not wearing seat belts



Fig. 38 The vehicle hits the wall: the occupants are not wearing seat belts

It is easy to explain how the laws of physics work in the case of a head-on collision: when a vehicle starts moving \Rightarrow Fig. 37, this is a certain amount of energy known as “kinetic energy” both in the vehicle and in the occupants.

The higher the speed and the greater the weight of the vehicle, the more energy there is to be absorbed in an accident.

The most significant factor, however, is the speed of the vehicle. If the speed doubles from 25 km/h (15 mph) to 50 km/h (30 mph), for example, the kinetic energy is multiplied by four.

The amount of “kinetic energy” depends on the speed of the vehicle and the weight of the vehicle and its passengers. The higher the speed and the greater the weight of the vehicle and the occupants, the more energy there is to be absorbed in an accident.

Vehicle occupants not wearing seat belts are not “attached” to the vehicle. As a result, in a frontal collision they will continue to move forward at the speed their vehicle was travelling just before the impact until something stops them! Because the passengers in our example are not restrained by seat belts, all of the vehicle occupants’ kinetic energy has to be absorbed at the point of impact \Rightarrow Fig. 38.

At speeds of 30 km/h (18 mph) to 50 km/h (30 mph), the forces acting on bodies in a collision can easily exceed one tonne (1000 kg or 2.205 pounds). At greater speed these forces are even higher.

This example applies not only to frontal accidents, but to all accidents and collisions.

Dangers of not using the seat belt



Fig. 39 A driver not wearing a seat belt is thrown forward violently



Fig. 40 The unbelted rear seat passenger is thrown forward violently, hitting the driver wearing a seat belt

Many people believe that the occupants can protect themselves with their hands in a minor collision. This is false!

Even at low speeds, the forces acting on the body in a collision are so great that it is not possible to brace oneself with just one's arms and hands. In a frontal collision, unbelted vehicle occupants are thrown forward and will make violent contact with the steering wheel, dash panel, windscreen or whatever else is in the way → Fig. 39.

The airbag system is not a substitute for seat belts. When triggered, airbags provide only additional protection. Airbags do not deploy in all types of accident. All occupants (including the driver) must be wearing seat belts properly during the trip, even if the vehicle is equipped with airbag systems. This will reduce the risk of critical or fatal injuries in the event of an accident – regardless of whether an airbag is fitted for the seat.

The airbag is only deployed once. To achieve the best possible protection, the seat belt must always be worn properly so that you will be protected in accidents in which no airbag is deployed. Vehicle occupants not wearing belts could be thrown from the vehicle and sustain even more severe or fatal injuries.

It is also important for the rear passengers to wear seat belts properly, as they could otherwise be thrown forward violently in an accident. Rear seat passengers who do not use seat belts endanger not only themselves but also the driver and other occupants → Fig. 40.

Seat belt protection



Fig. 41 Drivers with properly worn seat belts will not be thrown forward in the event of sudden braking

Wearing a correctly fastened seat belt can significantly change the situation. Properly worn seat belts hold the vehicle occupants in the correct sitting positions and substantially reduce the kinetic energy in the event of an accident. Seat belts also help to prevent uncontrolled movements that could lead to severe injuries. In addition, properly worn seat belts reduce the danger of being thrown from the vehicle → Fig. 41.

Vehicle occupants wearing their seat belts correctly benefit greatly from the ability of the belts to absorb kinetic energy. The front crumple zones and other passive safety features (such as the airbag system) are also designed to absorb the kinetic energy generated in a collision. Taken together, all these features reduce the energy released and decrease the risk of injury.

Our examples describe frontal collisions. Of course, properly worn seat belts substantially reduce the risk of injury in all other types of accidents. This is why it is so important to fasten seat belts before every trip, even when just driving "around the corner". Ensure that your passengers wear their seat belts as well.

Accident statistics have shown properly worn seat belts to be an effective means of considerably reducing the risk of severe injury and improving the chances of survival in a serious accident. Furthermore, properly worn seat belts improve the protection provided by deployed airbags in the event of an accident. For this reason, wearing a seat belt is required by law in most countries.

Although your vehicle is equipped with airbags, fasten and wear the seat belts. The front airbags, for example, are only triggered in some frontal accidents. The front airbags will not be triggered during minor frontal collisions, minor side collisions, rear collisions, rolls or accidents in which the airbag trigger threshold value in the control unit is not exceeded.

Therefore, you should always wear your seat belt and ensure that vehicle occupants have fastened their seat belts properly before you drive off!

Using seat belts

Checklist

Use of the seat belt ⇒ ⚠:

- ✓ Check the condition of all the seat belts at regular intervals.
- ✓ Keep the seat belts clean.
- ✓ Keep the seat belt web, the latch plate and the buckle free of foreign bodies and liquids.
- ✓ Do not jam or damage the seat belt or the latch plate when closing the door, for example.

Checklist (Continued)

- ✓ Never remove, modify or repair the seat belt or belt fastening mechanisms.
- ✓ Fasten your seat belt properly before each trip and keep it fastened.

Twisted seat belt

If it is difficult to remove the seat belt from the guide, the seat belt may have become twisted inside the side trim after being wound too quickly on unfastening:

- Pull out the seat belt completely, carefully pulling on the latch plate.
- Untwist the belt and guide it back, assisting it by hand.

Fasten the seat belt even if it is impossible to untwist it. In this case, the twisted area must not be in an area in direct contact with your body. Have the seat belt untwisted urgently by a Specialised workshop.

**WARNING**

An improperly handled seat belt increases the risk of sustaining severe or fatal injuries.

- Regularly check that the seat belts and their components are in perfect condition.
- Always keep your seat belt clean.
- Do not jam or damage the seat belt or rub it with sharp edges.
- Make sure there are no liquids or foreign bodies on the latch plate and in the buckle.

Fastening or unfastening a seat belt

Fig. 42 Insert the latch plate into the buckle





Fig. 43 Release the latch plate from the buckle


Properly worn seat belts hold the vehicle occupants in the position that most protects them in the event of an accident or sudden braking ⇒ ⚠. ▶

Fastening the seat belt

Fasten your seat belt before each trip.

- Correctly adjust the front seat ⇒ page 48.
- Engage the seat backrest in the upright position and correctly adjust the head restraint ⇒ .
- Pull the latch plate and place the belt webbing evenly across your chest and lap. Do **not** twist the seat belt when doing so ⇒ .
- Engage the latch plate in the buckle of the corresponding seat ⇒ Fig. 42.
- Pull the belt to ensure that the latch plate is securely engaged in the buckle.

Unfastening the seat belt

The seat belt must not be unfastened until the vehicle has come to a standstill ⇒ .

- Press the red button on the buckle ⇒ Fig. 43. The latch plate is released from the buckle.
- Guide the belt back by hand so that it rolls up easily and the trim will not be damaged.

 WARNING

An incorrectly worn seat belt web can cause severe or fatal injuries in the event of an accident.

- The seat belt cannot offer its full protection unless the backrests are in an upright position and the seat belt is worn correctly, according to your size.
- Unbuckling your seat belt while the vehicle is in motion can cause severe or fatal injuries in the event of an accident or sudden braking.

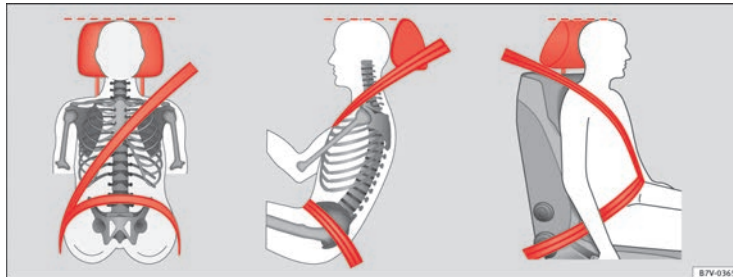
Seat belt position

Fig. 44 Correct seat belt position

Vehicle diagram

Prior to a journey...

While driving

Care, cleaning and maintenance

If and when

Technical Data



Fig. 45 Correct positioning of seat belts during pregnancy

Seat belts offer their maximum protection in the event of an accident and reduce the risk of sustaining severe or fatal injuries only when they are properly positioned. Furthermore, if the webbing is correctly positioned, the seat belt will hold the occupants in the optimum position to ensure the air-bag provides the utmost protection. The seat belt must therefore always be worn and the webbing correctly positioned.

Incorrectly worn seat belts can cause severe or even fatal injuries
 ⇒ page 48, Adjusting the seat position.

Correct seat belt position

- The shoulder part of the seat belt must lie on the centre of the shoulder, never across the neck or the arm, under the arm or behind the shoulder.
- The lap part of the seat belt must lie across the pelvis, never across the stomach.
- The seat belt must lie flat and fit comfortably. Pull the seat belt tight if necessary to take up any slack.

In the case of **pregnant women**, the seat belt must lie evenly across the chest and as low as possible over the pelvis, never across the stomach. Pregnant women must wear the seat belt properly at all times during the pregnancy ⇒ Fig. 45.

Adapting the position of the seat belt webbing to your size

The seat belt can be adapted using the following equipment:

- Front seat height adjustment.



WARNING

An incorrectly worn seat belt web can cause severe injuries in the event of an accident or sudden braking or manoeuvre.

- The seat belt cannot provide optimum protection if it is not correctly worn and the backrest is not tilted slightly backwards.
- The seat belt itself or a loose seat belt can cause severe injuries if the belt moves from hard areas of the body to soft areas (e.g. the stomach).
- The shoulder part of the seat belt must lie on the centre of the shoulder, never across the neck or the arm.
- The seat belt must lie flat and fit comfortably on the torso.
- The lap part of the seat belt must lie across the pelvis, never across the stomach. The seat belt must lie flat and fit comfortably on the pelvis. Pull the seat belt tight if necessary to take up any slack.
- Pregnant women must wear the lap part of the seat belt as low as possible over the pelvis and always lie it flat, “surrounding” the stomach.
- Do not twist the seat belt while it is fastened.
- Never pull the seat belt away from your body using your hand.
- Do not lie the seat belt across rigid or fragile objects, e.g. glasses, pens or keys.
- Never use seat belt clips, retaining rings or similar instruments to alter the position of the belt webbing.

**Note**

If your physical constitution prevents you from maintaining the correct position of the belt webbing, contact a Specialised workshop for help with any special devices to ensure the optimum protection of the seat belt and airbag. SEAT recommends visiting a Technical Service.

Automatic belt retainer, belt tension device, belt tension limiter

Seat belts are part of the vehicle safety concept ⇒ page 67 and consist of the following important functions:

Automatic belt retainer

Every seat belt is equipped with an automatic belt retainer on the shoulder belt. If the belt is pulled slowly or during normal driving, the system allows for total freedom of movement on the shoulder belt. However, during sudden braking, during travel in mountains or bends and during acceleration, the automatic belt retainer on the seat belt is locked is pulled quickly.

Belt tension devices

The seat belts for the front occupants are equipped with belt tensioners.

Sensors will trigger the belt tension devices during severe head-on, lateral and rear collisions and retract and tighten the seat belts. If the seat belt is loose, it is retracted to reduce the forwards movement of occupants or movement in the direction of the collision. The belt tension device works in combination with the airbag system. The belt tension device will not be triggered in the event of the vehicle overturning if the side airbags are not deployed.

If the belt tension device is triggered, a fine dust is produced. This is normal and it is not an indication of fire in the vehicle.

Belt tension limiter

The belt tension limiter reduces the force of the seat belt on the body in the event of an accident.

**Note**

The relevant safety requirements must be observed when the vehicle or components of the system are scrapped. These requirements are known to specialised workshops ⇒ page 65.

Service and disposal of belt tension devices

If you work on the belt tension devices or remove and install other parts of the vehicle when performing other repair work, the seat belt may be damaged. The consequence may be that, in the event of an accident, the belt tension devices function incorrectly or not at all.

Observe regulations so that the effectiveness of the belt tension device is not reduced and that removed parts do not cause any injuries or environmental pollution. These requirements are known to qualified dealerships.

**WARNING**

Improper handling and home-made repairs of seat belts, automatic belt retainers and tension devices increase the risk of sustaining severe or fatal injuries. The belt tension device may fail to trigger or may trigger in the wrong circumstances.

- Never attempt to repair, adjust or remove or install parts of the belt tension devices or seat belts. Any work must be performed by a specialised workshop only ⇒ page 222.
- Do not repair belt tension devices and automatic belt retainers. Replace them.

**For the sake of the environment**

Airbag modules and belt tensioner may contain perchlorate. Observe the legal requirements for their disposal. ■

Airbag system

Introduction

Front airbags have been installed for both driver and passenger. The front airbags can also protect the chest and head of driver and passenger if the seats, seat belts head restraints and, for the driver, the steering wheel are correctly adjusted and used. Airbags are considered as additional safety equipment. An airbag cannot replace the safety belt, which must be worn at all times, even in front seats where front airbags have been installed.

Additional information and warnings:

- Driving tips ⇒ page 25
- Correct sitting position ⇒ page 48
- Seat belts ⇒ page 57
- Child seats (accessories) ⇒ page 76
- Care and cleaning of the vehicle interior ⇒ page 205
- Accessories, parts replacement, repairs and modifications ⇒ page 222
- Notes for the user ⇒ page 233

WARNING

Never exclusively trust the airbag system as a means of protection.

- Even when triggered, airbag protection is only auxiliary.
- The airbags provide the best protection when the seat belts are properly fastened, thus reducing the risk of sustaining injuries ⇒ page 57, Seat belts.
- Before each trip, every occupant must sit properly, correctly fasten the seat belt belonging to his or her seat and keeping it fastened throughout the trip. This rule is valid for all occupants.

WARNING

Occupants sitting in the front of the vehicle must never carry any objects in the deployment space between them and the airbags, as this increases the risk of sustaining injuries if the airbag is triggered. This modifies the airbag deployment space or the objects may fly uncontrollably and hit your body.

- Never carry objects in your hand or on your lap while the vehicle is in motion.
- Never transport objects on the front passenger seat. In the event of sudden braking and manoeuvres, the objects may end up in the airbag deployment space and fly uncontrollably around the interior if the airbag is activated.
- Occupants of the front and rear seats must never carry any other people, pets or objects in the deployment space between them and the airbags. Make sure children and other passengers also respect this recommendation.

WARNING

The airbag system provides protection for one accident only. If they have been deployed, replace them.

- Ensure deployed airbags and the system components involved are immediately replaced with new, SEAT-approved components for the vehicle.
- Have any repairs or modifications carried out at a Specialised workshop. Specialised workshops have the necessary tools, diagnostics equipment, repair information and qualified personnel.
- Never fit recycled or reused airbag components in your vehicle.
- Never modify the airbag system components.

**WARNING**

If the airbags are triggered, a fine dust is produced. This is normal and it is not an indication of fire in the vehicle.




- This fine dust may irritate the skin and eyes and cause breathing difficulties, particularly in people suffering from or who have suffered from asthma or other illnesses of the respiratory tract. To reduce breathing difficulties, get out of the vehicle and open doors and windows to breathe in fresh air.
- Should you touch the dust, wash your hands and face using a mild soap and water before you eat.
- Prevent the dust from affecting the eyes or open wounds.
- Rinse your eyes with water if you have dust in them.

**WARNING**

Solvents cause the surfaces of the airbag modules to become porous. If an airbag is accidentally triggered, the detachment of plastic parts could cause serious injury.

- Never clean the dash panel and the surfaces of the airbag modules with cleaners containing solvents.



Types of front passenger airbag systems

There are 2 different SEAT front passenger airbag systems:	
A	B
Characteristics of the passenger front airbag without disabling.	Characteristics of the front passenger front airbag that can be disabled manually ⇒ page 73.
- * Control lamp  on the instrument panel.	- Control lamp  on the instrument panel.
- Front passenger airbag located in dash panel.	- PASSENGER AIR BAG OFF  control lamp on the dash panel.
	- Key switch in the glove compartment on the front passenger side of the dash panel.
	- Front passenger airbag located in dash panel.
- Description: airbag system	- Description: airbag system with front passenger airbag disabling.
	- Description: airbag system without disabling.*



Control lamps



Fig. 46 Control lamp for disabling the front passenger airbag on the dash panel

lights up	Location	Possible cause	Solution
	Instrument panel	Fault in airbag system and seat belt tensioners.	Have the system checked immediately by a Specialised workshop.
OFF	Dash panel.	Fault in the airbag system.	Have the system checked immediately by a Specialised workshop.
		Front passenger airbag disabled.	Check whether the airbag should remain disabled.

Several warning and control lamps light up for a few seconds when the ignition is switched on while a test of the function is being carried out. They will switch off after a few seconds.

If the PASSENGER AIR BAG OFF  warning lamp **does not remain lit** or if it is lit together with the control lamp  on the instrument panel and the front passenger airbag is disabled, there may be a fault in the airbag system ⇒ ⚠.

**WARNING**

In the event of a fault in the airbag system, the airbag may not trigger correctly, may fail to trigger or may even trigger unexpectedly, leading to severe or fatal injuries.

- Have the airbag system checked immediately by a Specialised workshop.
- Never mount a child seat in the front passenger seat or remove the mounted child seat! The front passenger airbag may deploy during an accident in spite of the fault.

**CAUTION**

Always pay attention to any lit lamps and to the corresponding descriptions and instructions to avoid damage to the vehicle.

Description and function of the airbag

The airbag can protect vehicle occupants in the event of an accidents, cushioning the movement of the occupants in the direction of the collision in frontal and side accidents.


Deployed airbags fill with a propellant gas. This causes the airbag covers to break and the airbags to deploy extremely quickly in their entire deployment space within fractions of a second. When an occupant with the seat belt properly fastened puts pressure on the inflated airbag, the propellant gas escapes to absorb the force of the impact and slow the movement. This reduces the risk of severe or fatal injuries. Airbag deployment does not mean that other types of injury such as swelling, bruising and skin injuries can be ruled out. Upon deployment of the airbag, friction can cause the generation of heat.

Airbags do not protect the arms or the lower part of the body.

The most important factors for triggering the airbag are the type of accident, the angle of impact, the vehicle speed and the characteristics of the object the vehicle hits. Therefore, airbags are not triggered every time the vehicle is visibly damaged.


The activation of the airbag system depends on the magnitude of the deceleration of the vehicle caused by a collision, which registers through an electronic control unit. If the deceleration magnitude value is below the reference value programmed in the control unit, the airbags will not deploy despite serious damage being caused to the vehicle by the accident. Damage suffered by the vehicle, reparation costs or absence of damage suffered from the accident are not indications of whether an airbag should have been deployed. Due to the varying nature of collision situations, it is impossible to define a speed range of the vehicle and reference values. For this reason, it is not possible to cover all types of collisions and collision angles resulting in the deployment of the airbag. Factors necessary for the airbag to be deployed can be, the characteristics of the object (hard or soft) against which the vehicle collides, the collision angle and the vehicle speed.

Airbags act in conjunction with three-point seat belts in the event of certain accidents, when the vehicle deceleration rate is severe enough to trigger the airbags. Airbags only deploy once and only under certain circumstances. Seat belts remain present to offer protection in situations where airbags are not triggered or where they have already deployed. For example, when a vehicle hits another after an initial collision or is hit by another vehicle.

The airbag system is an integral part of the vehicle's passive safety system. The airbag system can only work effectively when the occupants are wearing their seat belts correctly and have adjusted the head restraints properly  => page 48.

Vehicle safety components

The following safety equipment makes up the vehicle safety design to reduce the risk of severe and fatal injuries. Depending on the vehicle equipment, some equipment may not be fitted in the vehicle or may not be available in some markets. ►

- Optimised seat belts for all seats.
- Seat belt tension devices for driver and passenger.
- Seat belt force limiters for driver and passenger.
- Seat belt warning lamp.
- Frontal airbags for driver and passenger.
- Side airbags for driver and passenger.
- Airbag control lamp .
- Control units and sensors.
- Head restraints optimised for rear-end collision.
- Adjustable steering column.
- If necessary, anchor points for child seats for the rear seats.
- Where applicable, mountings for the child seat upper retaining strap.

Situations when the front and side airbags do not deploy:

- If the ignition is switched off during the collision.
- In frontal collisions when the deceleration measured by the control unit is too low.
- In minor side collisions.
- In rear collisions.
- In the event of the vehicle overturning.
- When the impact speed is lower than the reference value set in the control unit. ■

Front airbags

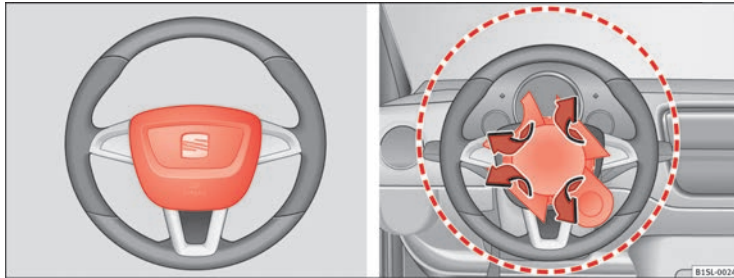


Fig. 47 Location and deployment area of the front airbag for the driver

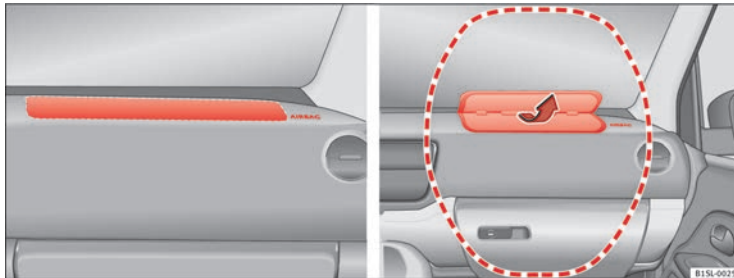


Fig. 48 Location and deployment area of the front airbag for the driver

In conjunction with the seat belts, the front airbag system gives the front occupants additional protection for the head and chest in the event of a severe frontal collision. Always remain as far away as possible from the front airbag ⇒ page 48. This way, the front airbags can completely deploy when triggered, providing their maximum protection.

The front airbag for the driver is located in the steering wheel ⇒ Fig. 47 and the airbag for the front passenger is located in the dash panel ⇒ Fig. 48. Airbags are identified by the word "AIRBAG". ▶

When the front airbags are triggered they fill the zones marked in red ⇒ Fig. 47 and ⇒ Fig. 48 (radius of action). Therefore, objects should never be placed or mounted in these areas ⇒ ⚠. Factory-fitted accessories are outside the range of the front airbag for the driver and the front passenger, e.g. the baseplate for the mobile telephone support.

The airbag covers fold out of the steering wheel ⇒ Fig. 47 or dash panel ⇒ Fig. 48 when the driver and front passenger airbags are triggered. The airbag covers remain connected to the steering wheel or the dash panel.

⚠ WARNING

The airbag is deployed at high speed in fractions of a second.

- Always keep the deployment areas of the front airbags vacant.
- Never secure objects to the covers or in the deployment area of the airbag modules, e.g. drink holders or phone supports.
- The deployment space between the front passengers and the airbags must not in any case be occupied by other passenger, pets and objects.
- Never fix any object to the windscreen above the front airbag on the front passenger side.
- Do not alter, cover or stick anything to the steering wheel hub or the surface of the airbag module on the passenger side of the dash panel.

⚠ WARNING

Front airbags are deployed in front of the steering wheel ⇒ Fig. 47 and the dash panel ⇒ Fig. 48.

- When driving, always hold the steering wheel on the outer edge of the ring with both hands: 9 o'clock and 3 o'clock position.

⚠ WARNING (Continued)

- Adjust the driver seat so that there is a distance of at least 25 cm (10 inches) between the centre of your chest and the hub of the steering wheel. If your physical constitution prevents you from meeting these requirements, make sure you contact a Specialised workshop.
- Adjust the front passenger seat so there is as much distance as possible between the front passenger and the dash panel.

Deactivating and activating the front passenger airbag using the key switch

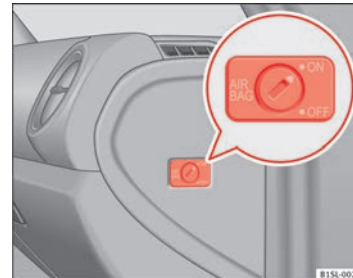



Fig. 49 On front passenger side: key switch for disabling and enabling the front passenger airbag


Disable the front passenger airbag when a rear-facing child seat is mounted.

Deactivating the front passenger airbag



- Switch the ignition off.
- Open the door on the front passenger side.
- Unfold the key shaft ⇒ page 28.



- Using the vehicle key, turn the key switch to **OFF** ⇒ Fig. 49.
- Close the door on the front passenger side.
- The PASSENGER AIR BAG OFF  control lamp on the dash panel will remain lit while the ignition is switched on ⇒ page 69.

Activating the front passenger airbag

- Switch the ignition off.
- Open the door on the front passenger side.
- Unfold the key shaft ⇒ page 28.
- Using the vehicle key, turn the key switch to **ON** ⇒ Fig. 49.
- Close the door on the front passenger side.
- Check that the PASSENGER AIR BAG OFF  control lamp on the dash panel does *not* light up ⇒ page 69 while the ignition is switched on.

How to know whether the front passenger airbag is disabled

Disabling of the front passenger airbag is **only** indicated by the PASSENGER AIR BAG OFF  control lamp that remains lit on the dash panel (OFF ; remains yellow) ⇒ page 69.

If the control lamp OFF  on the dash panel **does not remain lit** or is lit in combination with the control lamp  on the instrument panel, a child restraint system cannot be mounted on the front passenger seat for safety reasons. The front passenger airbag may deploy during an accident.



WARNING

- **Only disconnect the front passenger airbag in special cases.**
- **Disconnect and connect the front passenger airbag when the ignition is switched off to avoid damage to the airbag system.**
- **It is the driver's responsibility to ensure that the key operated switch is set to the correct position.**



WARNING (Continued)

- **Only disconnect the front passenger airbag when a child seat is to be mounted under exceptional circumstances.**
- **As soon as the child seat is no longer needed on the front passenger seat, reconnect the front passenger seat airbag.**

Side airbags

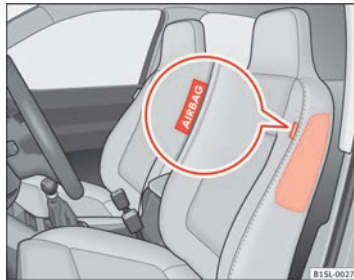


Fig. 50 On the side of the front seat: location of the side airbag



Fig. 51 On the left side of the vehicle: deployment area of side airbag

The side airbags are located in the outer cushion of the driver and front passenger seat backrests ⇒ Fig. 50. Their position is indicated by the word "AIRBAG". The area marked in red ⇒ Fig. 51 indicates the side airbag deployment zone.

In the event of a side-on collision, the side airbag will deploy in the side of the vehicle affected ⇒ Fig. 51, thus reducing the risk of injuries to passengers on the side of the body and the head facing the accident side.

! WARNING

The airbag is deployed at high speed in fractions of a second.

- Always keep the deployment areas of the side airbags vacant.
- The deployment space between the front passengers and the airbags must not in any case be occupied by other passenger, pets and objects.
- Do not mount accessories on the doors.
- Only used protective covers for the seats that are approved for the vehicle. Otherwise, the side airbag would be obstructed when deployed.

! WARNING

Incorrect handling of the driver's and front passenger's seat could prevent the side airbag from deploying properly and cause severe injuries.

- Never remove the front seats of the vehicle or modify any of their components.
- Great forces must not be exerted on the backrest bolsters because the side airbags might not deploy correctly, might not deploy at all or might deploy unexpectedly.
- Any damage to the original seat upholstery or around the seams of the side airbag units must be repaired immediately by a Specialised workshop.

Child seats (accessories)

Introduction

Before transporting babies and children in a child seat placed in the front passenger seat, first completely read the information regarding the airbag system.

This information is extremely important for driver and passenger safety, particularly that of babies and children.

SEAT recommends the use of child seats from the SEAT accessory programme. These child seats have been designed and tested for use in SEAT vehicles. You can purchase child seats with different mountings from a SEAT dealership.

Additional information and warnings:

- Seat belts ⇒ page 57
- Airbag system ⇒ page 67



WARNING

Make sure children are properly belted in and correctly secured to avoid severe or fatal injuries while the vehicle is in motion.

- Never use a rear-facing child seat in the front passenger seat if the front passenger airbag is enabled.
- Children up to 12 years old should always travel on the rear seat.
- Children must always be protected with an approved child restraint system suited to their height and weight.
- Children must assume the proper sitting position and be properly belted in while travelling.



WARNING (Continued)

- Ensure the backrest of a seat is upright when a child seat is being used on it.
- Do not allow the child's head or other part of his or her body to enter the deployment area of the side airbags.
- Make sure the seat belt webbing is correctly positioned.
- Never hold children or babies on your lap or in your arms.
- Only one child may occupy a child seat.
- Please read and observe the child seat manufacturer's handling instructions.



WARNING

An empty or loose child seat could fly uncontrollably around the vehicle interior and cause injuries in the event of an accident or sudden braking.

- When not in use while the vehicle is in motion, always safely secure it or store it in the luggage compartment.



Note

Replace the child seat after an accident, as it may have invisible damage. ■

General information on transporting children in the vehicle

Legal regulations and provisions will always take priority over the descriptions of this instruction manual. There are different regulations and provisions for the use of child seats and their mountings (⇒ table on page 77). In some countries, for example, the use of child seats on certain seats in the vehicle may be forbidden.

The physical principles and the forces acting on the vehicle in the event of a collision or other type of accidents also apply to children ⇒ page 57. However, unlike adults and youngsters, children do not have fully developed muscle and bone structures. In the event of an accident, children are subject to a greater risk than adults of sustaining severe injuries.

Given that children's bodies are not yet fully developed, child restraint systems must be used that are especially adapted to their height, weight and constitution. There are laws in force in many countries that determine the use of approved seat systems for transporting babies and children.

Only used authorised, approved child seats that are suitable for the vehicle. Always consult with a SEAT dealership or a Specialised workshop should you have any doubts.

Checklist

To transport children in the vehicle ⇒ :

- ✓ Observe the legal requirements specific to each country.
- ✓ For safety reasons, SEAT recommends that children under 12 years of age are transported on the rear seats.
- ✓ Only if you have no alternative should a child travel on the front passenger seat ⇒ page 79. The safest place in the vehicle is on the rear seat behind the front passenger seat.
- ✓ Child must always use a child restraint system when travelling in the vehicle. The child restraint system must be suitable for the height, weight and constitution of the child.

¹⁾ ECE-R: Economic Commission for Europe Regulation.

- ✓ Only one child may occupy a child seat.
- ✓ Follow the user instructions from the child seat manufacturer and always keep them in the vehicle.
- ✓ If the child seat is secured using the seat belt, guide the seat belt through or around the child seat according to the instructions of the child seat manufacturer.
- ✓ Make sure the seat belt webbing is correctly positioned and that the child is sitting properly.
- ✓ The child seat should be installed on the rear seat behind the front passenger seat so that the child can exit the vehicle on the kerb side.
- ✓ Do not leave toys or other loose objects on the child seat or on the seat while the vehicle is in motion.

Specific child seat regulations for each country (selection)

Child seats must comply with the ECE-R 44¹⁾ regulation. You can consult additional information at your SEAT dealership at the internet address www.seat.es.

Categorisation of child seats according to ECE-R 44

Weight category	Weight of the child	Age
Group 0	children up to 10 kg	up to approximately. 9 months
Group 0+	children up to 13 kg	up to approximately. 18 months
Group 1	9 to 18 kg	approx. 8 months to 3 1/2 years
Group 2	15 to 25 kg	approx. 3 to 7 years
Group 3	22 to 36 kg	approx. 6 to 12 years

Not all children fit in the seat of their weight group. Nor do all seats adapt to the vehicle. Therefore, always check whether the child fits properly in the child seat and whether the seat can be installed safely in the vehicle. ►

Child seats approved under the ECE-R 44 regulation are fitted with the corresponding approval symbol. The sign is an upper-case E in a circle with the identification number below it.

⚠ WARNING

Not following the checklist prepared for your own safety could lead to accidents and severe injuries.

- Always follow the check list and perform the necessary operations.

⚠ WARNING

In general, the rear seat is always the safest place for children, who are belted correctly, in the event of an accident.

- A suitable child seat that is correctly installed and used on one of the rear seats offer the most protection possible for babies and children up to 12 years in most accidents.

Different mounting systems

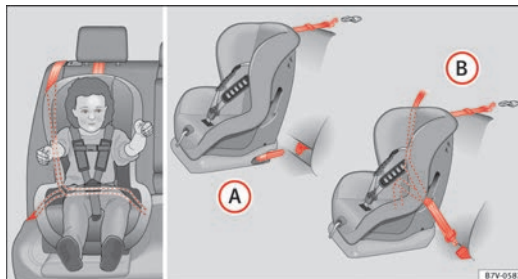


Fig. 52 On the rear seats: figure (A) shows the basic child restraint system mounting using lower retaining rings and the upper retaining strap. Figure (B) shows the child restraint system mounting using the vehicle's seat belt

Always secure child seats properly and safely in the vehicle according to the child seat manufacturer's installation instructions.

Mounted child seats must rest correctly on the vehicle's seat and must not move or rock more than 2.5 cm.

Child seats equipped for a Top Tether strap must also be secured using the Top Tether retaining strap in the vehicle ⇒ page 83. Only attach the retaining strap to the corresponding retaining rings. Not all rings can be used with the Top Tether system. Always tighten the Top Tether retaining strap so that the child seat fits snugly against the corresponding seat in the vehicle. ▶

Specific mounting systems for each country

Attachment variants ⇒ Fig. 52:

- Ⓐ Europe: ISOFIX retaining rings and upper retaining strap ⇒ page 81 and ⇒ page 83.
- Ⓑ Three-point seat belt and upper retaining strap ⇒ page 80.

The systems include the child restraint system mounting with an upper retaining strap (Top Tether) and lower anchoring points on the seat. ■

Use of the child seat on the front passenger seat

Transporting children on the front passenger seat is not permitted in all countries. Furthermore, not all child seats are approved for use on the front passenger seat. Your SEAT dealership has an updated list of all approved child seats. Only used child seats that are approved for each vehicle.

The frontal airbag on the front passenger side is highly dangerous for a child. The front passenger seat is life-threatening to a child if he or she is transported in a rear-facing child seat.

If a rear-facing child seat is secured to the front passenger seat, an inflating airbag can strike it with such great force that severe or fatal injuries may result ⇒ ⚠. Therefore, rear-facing child seats must **never** be used on the front passenger seat when the front passenger airbag is enabled.

Only use a rear-facing child seat on the front passenger seat if the front passenger airbag is disabled. When it is disabled, the yellow PASSENGER AIR BAG OFF ⚠ ⇒ page 67 control lamp on the dash panel will be lit. **If you cannot disable the front passenger airbag and it remains enabled, it is forbidden to transport children on the front passenger seat ⇒ ⚠.**

Things to note if using a child seat on the front passenger seat:

- The front passenger front airbag **must** be disabled ⚠ when using a rear-facing child seat ⇒ page 67.
- The backrest of the front passenger seat must be upright.
- Move the front passenger seat as far back as possible.
- The backrest of the front passenger seat must be upright.

Suitable child seats

The child seat must be authorised by the manufacturer especially for use on a front passenger seat with a frontal or side airbag.

Universal seats for children can be fitted in the front passenger seat, in groups 0, 0+, 1, 2 or 3 according to the ECE-R 44 regulation.

⚠ WARNING

If a child seat is mounted on the front passenger seat, the risk of the child sustaining severe or fatal injuries in the event of an accident increases. Rear-facing child seats must **never** be mounted on the front passenger seat when the front passenger airbag is enabled. This is life-threatening to the child should the frontal airbag deploy, as the child seat would be struck by the inflated airbag and thrown against the backrest.

⚠ WARNING

If, in exceptional circumstances, a child must be transported in a rear-facing child seat on the front passenger seat, strictly observe the following:

- Always disable the front passenger airbag and leave it disabled.
- The child seat must be approved by the manufacturer for use on a front passenger seat with frontal and side airbag.
- Follow the installation instructions of the child seat manufacturer and observe the warnings. ▶

⚠ WARNING (Continued)

- Move the front passenger seat as far back as possible and adjust it to its highest position to keep as far away as possible from the frontal air-bag.
- Move the backrest to the upright position.
- Children must always be protected with an approved child restraint system suited to their height and weight.

Use of the child seat on the rear seat

If a child seat is mounted on the rear seat, adapt the position of the front passenger seat so that the child has enough space. Therefore, adapt the front passenger seat to the size of the child seat and the height of the child. Ensure the passenger is in the correct position ⚠ ⇒ page 48.

Suitable child seats

The manufacturer must authorise the child seat for use in the rear seats with side airbags.

Universal seats for children can be fitted in the passenger seat, in groups 0, 0+, 1, 2 or 3 according to the ECE-R 44 regulation.

The rear seats are suitable for child seats with the **ISOFIX system** specially designed for this type of vehicle in accordance with regulation ECE-R 44.

ISOFIX child seats approved for rear seats

ISOFIX child seats are divided into certified categories “universal”, “semi-universal” or “specific categories for the vehicle”.

- If the ISOFIX child seat is certified “universal”, it must be supported by the lower anchor points and the Top Tether retaining strap.
- If the ISOFIX child seat is certified “semi-universal” or “specific categories for the vehicle”, check that the child seat is certified for the vehicle before employing it. The child seat manufacturer supplies, in addition to the

ISOFIX child seat, a list of vehicles for which the corresponding ISOFIX child seat has been certified. If necessary, contact the child seat manufacturer for an updated list of vehicles. ■

Securing child seats with the seat belt

The seat belt may be used to secure child seats with the **universal** marking (on the orange label) to the vehicle seats marked with a **u** in the table below.

Category	Front passenger	Rear seats
Group 0 Up to 10 kg	u	u
Category 0+ Up to 13 kg	u	u
Group 1 9 to 18 kg	u	u
Group 2 15 to 25 kg	u	u
Group 3 22 to 36 kg	u	u

Securing the child seat using the seat belt

- Please read and observe the child seat manufacturer's handling instructions.
- Move the front passenger seat, or the rear seat bench back as far as possible and, in the case of an adjustable backrest, set it in the upright position ⇒ page 48.
- Positioning the child seat on the seat according to the manufacturer's instructions.
- Fasten the seat belt or pass it around the child seat structure in the manner described in the manufacturer's instructions. ▶

- Make sure the seat belt is not twisted.
- Insert the latch plate into the buckle for the appropriate seat and push it down until it is securely locked with an audible click.
- Ensure that the upper belt web lies tightly on the child seat.
- Pull the belt (it must be no longer possible to pull the lower belt webbing out).

Removing the child seat

The seat belt must not be unfastened until the vehicle has come to a standstill ⇒ ⚠.

- Press the red button on the buckle. The latch plate is released from the buckle.
- Guide the belt back by hand so that it rolls up easily and the trim will not be damaged.
- Remove the child seat from the vehicle.



WARNING

Unbuckling the seat belt while the vehicle is in motion can cause severe or fatal injuries in the event of an accident or sudden braking.

- The seat belt must not be unfastened until the vehicle has come to a standstill.

Securing the child seat using the lower anchor points (ISOFIX, LATCH)

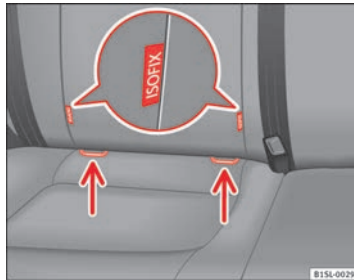


Fig. 53 On the vehicle seat: Identification variants of the anchor points for the child seats

Each seat of the rear seat bench has **two** retainers named lower anchor points.

Overview of ISOFIX installation

In compliance with the European directive ECE 16, The following table details the installation possibilities for ISOFIX child seats with the lower anchor points in each of the vehicle seats.

The allowed body weight for the child seat or information regarding size **A** to **G** is indicated on the label on the child seat with certification "universal" or "semi-universal".

	Group (weight category)									
	Group 0: children up to 10 kg		Group 0: children up to 10 kg			Group 1: 9 to 18 kg				
	Group 0+: children up to 13 kg									
Installation direction	facing backwards (in the direction opposite to travel)		facing backwards (in the direction opposite to travel)			facing backwards (in the direction opposite to travel)		facing forwards (in the direction of travel)		
Size	F	G	C	D	E	C	D	A	B	B1
installed on front passenger seat	Seat does not have anchor points, it is not possible to secure with ISOFIX/LATCH									
Installed on the rear seat bench	IL-SU		IL-SU			IL-SU		IUF/IL-SU		

IL-SU: seat suitable for installing an ISOFIX child seat with certification "semi-universal", take note of the list of vehicles of the manufacturer of the child seat.

IUF: seat suitable for the installation of an ISOFIX child seat with certification "universal" and with Top Tether retaining strap.

Child seats with rigid mounting

For the installation of a child seat with rigid mounting auxiliary introduction elements can be used. Using auxiliary introduction elements facilitates installation and protects upholstery. Auxiliary introduction elements form part of the supply volume of the child seat or can be acquired at a SEAT dealership. If necessary, auxiliary introduction elements are inserted in both anchor points of the vehicle ⇒ ①.

- Observe the manufacturer's instructions when installing and removing the child seat ⇒ ⚠.
- Press the child seat onto the retaining rings ⇒ Fig. 53 in the direction of the arrow. Safely engage the child seat and click it audibly into place.
- Pull on both sides of the child seat to ensure that it is secure.

Child seat with adjustable retaining straps

- Observe the manufacturer's instructions when installing and removing the child seat ⇒ ⚠.
- Place the child seat on the seat cushion and attach the retaining strap hooks to the retaining rings ⇒ Fig. 53.
- Tighten the straps evenly using the corresponding adjustment device. The child seat must sit flush against the vehicle seat.
- Pull on both sides of the child seat to ensure that it is secure.



WARNING

The lower anchor points for child seats do not include rings. Only secure booster seats to lower anchor points.



CAUTION

- To avoid making permanent marks in the padding, remove the auxiliary introduction elements from the anchor points when the child seat is not installed in the vehicle anchor points.
- To prevent damage being done to the upholstery, the padding or the auxiliary introduction elements, always remove the auxiliary introduction elements from the anchor points before folding the rear seat bench. ■

Securing a child seat using a Top Tether retaining strap

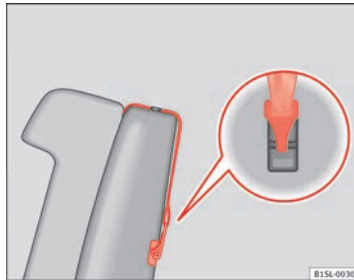



Fig. 54 Example of an upper retaining strap connected.

- Observe the manufacturer's instructions when installing and removing the child seat ⇒ .
- Unlock the seat backrest and fold it gently forward ⇒ page 55.
- Remove the head restraints situated behind the child seat and store them safely in the vehicle ⇒ page 48.
- Guide the upper retaining strap from of the child seat back to the luggage compartment, feeding it through the seat backrest and the rear shelf.
- Fold back the seat backrest and push it firmly into the lock.
- Secure the child seat to the lower anchor points ⇒ page 81
- Hook the upper retaining strap in the luggage compartment, to the corresponding retaining ring ⇒ Fig. 54.
- Tighten the strap so that the top of the child seat rests on the backrest.



WARNING

Child seats with lower anchor points and with an upper retaining strap must be installed in line with the manufacturer's instructions. Failure to comply could result in severe injuries.

- Always secure just *one* retaining strap to a child seat with the luggage compartment retaining ring.
- Always use the correct retaining rings for the retaining strap.
- Never secure the retaining strap to a retainer.

Lights and visibility

Lights

Introduction

Observe the legal requirements regarding the use of vehicle lights in each country.

The driver is personally responsible for the correct use and adjustment of the lights in all situations.

Additional information and warnings:





- Exterior detail ⇒ page 6
- SEAT information system ⇒ page 22
- Changing bulbs ⇒ page 264

WARNING

If the headlights are set too high and the main beam is not used correctly, there is a risk of dazzling or distracting other road users. This could result in serious accident.

- Always make sure that the headlamps are correctly adjusted.
- Never use the main beam or flashed headlamps as this could dazzle other drivers.

Warning lamps

lights up	Possible cause	Solution
	Rear fog light switched on.	⇒ page 86.
	Fog lights switched on.	⇒ page 86.
	Left or right turn signal. The control lamp flashes twice as fast when a vehicle turn signal is faulty.	If necessary, check the vehicle lighting.
	Main beam on or flasher on.	⇒ page 85.

Several warning and control lamps light up for a few seconds when the ignition is switched on while a test of the function is being carried out. They will switch off after a few seconds.

WARNING

If the warning lamps are ignored, the vehicle may stall in traffic, or may cause accidents and severe injuries.

- Never ignore the warning lamps.
- Stop the vehicle safely as soon as possible.
- Park the vehicle at a suitable distance away from the traffic ensuring that the exhaust system is not in contact with inflammable material, for example, dry grass, fuel, oil, etc.
- A faulty vehicle represents a risk of accident for the driver and for other road users. If necessary, switch on the hazard warning lamps and put out the warning triangle to advise other drivers.

! CAUTION

Failure to heed the warning lamps when they appear may result in faults in the vehicle.

Turn signal and main beam lever

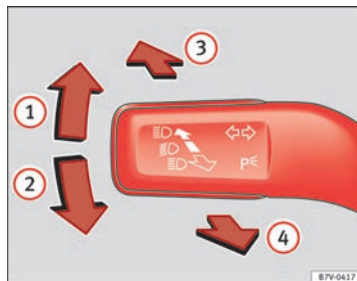


Fig. 55 Turn signal and main beam lever in their initial position

Move the lever to the required position:

- ① Right turn signal.
- ② Left turn signal.
- ③ Switching on main beam ⇒ ⚠. When the main beam is switched on, the warning lamp is switched on in the instrument panel.
- ④ Switch on the flasher or switch off the main beam headlights. The *flash-d beam* comes on if the lever is pressed. The warning lamp will light up during this process.

Push the lever all the way down to turn off the corresponding function.

Convenience turn signals

For the convenience turn signals, move the lever as far as possible upwards or downwards and release the lever. The turn signal will flash 3 times.

The convenience indicators can be deactivated at a Specialised workshop.



WARNING

Incorrect use of the headlamps may cause accidents and serious injury, as the main beam may distract or dazzle other drivers.



Note

The turn signal only works when the ignition is switched on. The hazard warning lights system also works when the ignition is switched off ⇒ page 240.



Note

If any of both turn signals fails, the warning lamp will start flashing twice faster than normal.



Note

The *main beam headlights* can only be switched on if the dipped beam headlights are already on.

Turning on and off lights

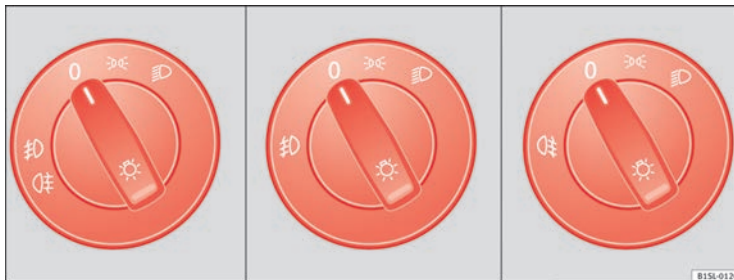


Fig. 56 Next to the steering wheel: diagram of some of the types of light switch

Observe the legal requirements regarding the use of vehicle lights in each country.

Turn the light switch to the required position ⇒ Fig. 56:

	when the ignition is turned off	when the ignition is on
0	Fog lights, dipped beam and side lights off.	Lights off, daytime driving light on.
☞☜	Side light on.	Side light on.
☞☜☞	Dipped beam off; if necessary, the side light comes on for a time.	Dipped beam switched on.

Fog lights*

The control lamp ☞☜ appears on the fog lights control connected.

- Switching on the fog lights ☞☜: Turn the switch to position ☞☜ or pull out ☞☜ to the first stop.
- Switching on the rear fog light ☞☜☞: turn the light switch to position ☞☜☞ or pull out ☞☜☞ to the maximum.
- To switch off the fog lights, press the light switch or turn it to position 0.

Audible warnings to advise the driver that the lights have not been switched off

If the key is not in the ignition and the driver door is open, an audible warning signal is heard in the following cases: This is a reminder to turn off the lights.

- When the light switch is in position ☞☜.
- When the light switch is in position ☞☜☞.

**WARNING**

The side lights or daytime driving lights are not bright enough to illuminate the road ahead and to ensure that other road users are able to see you.

- Always use your dipped beam head lights if it is raining or if visibility is poor.

Lights and visibility: functions

Parking light remains on both sides

If when switching off the ignition, the light control remains in the position \Rightarrow and the vehicle is closed from outside, both headlights, in addition to the side lights and the rear lights will light up.

Daytime driving light

The daytime driving light consists of individual lights in the front headlamps.

When the daytime driving light is switched on, only the individual lights come on \Rightarrow

The daytime lights are switched on each time the ignition is turned on if the light switch is in position 0.

Switching the daytime driving light on and off

To switch the daytime driving light on or off, it is necessary to fit or remove the corresponding fuse. Ask for professional assistance for this.

**WARNING**

If the road is not well-lit and the vehicle is not clearly visible to other drivers, there is a risk of accident.

- Never use the daytime driving light if the road is not well-lit as a result of the weather conditions and poor visibility. The daytime driving lights are not bright enough to illuminate the road ahead and to ensure that other road users are able to see you.
- The rear lights do not come on with the daytime driving light. A vehicle which does not have the rear lights on may not be visible to other drivers in the darkness, if it is raining or in conditions of poor visibility.

**Note**

The headlights, rear lights and turn signals may mist up temporarily on the inside in cool or damp weather. This is normal and in no way effects the useful life of the vehicle lighting system.

Adjusting the headlights

In those countries where vehicles drive on the other side of the road to the home country, the asymmetric dipped beam may dazzle drivers of oncoming vehicles.

For this reason, stickers may need to be used to cover the headlights when driving abroad. For further information, please refer to a specialised workshop. SEAT recommends visiting a Technical Service.

**Note**

The use of stickers to cover headlights is only permitted over a short period. To modify the direction of the headlamps more permanently, please take the vehicle to a specialised workshop. SEAT recommends visiting a Technical Service.

Headlight range control, lighting of instruments and controls

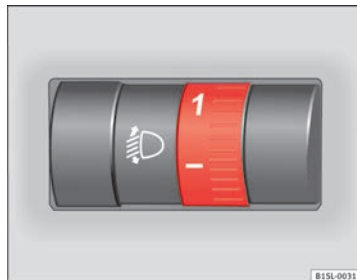


Fig. 57 Next to the steering wheel: Headlight range control

Headlamp height adjustment

The headlight range control ⇒ Fig. 57 is modified according to the value of the headlight beam and the vehicle load status. This offers the driver optimum visibility and the headlights do not dazzle oncoming drivers ⇒ ⚠.

The headlights can only be adjusted when the dipped beam is switched on.

To reset, turn switch ⇒ Fig. 57:

Value	Vehicle load status ^{a)}
–	Two front occupants, luggage compartment empty
1	All seats occupied, luggage compartment empty
2	All seats occupied, luggage compartment full.
3	Driver only, luggage compartment full.

^{a)} If the vehicle load does not correspond to those shown in the table, it is possible to select intermediary positions.

Instrument and switch lighting

When the side lights or dipped beam headlights are switched on, the lighting for instruments and controls lights up at a constant brightness.

⚠ WARNING

Heavy objects in the vehicle may mean that the headlights dazzle and distract other drivers. This could result in serious accident.

- Adjust the light beam to the vehicle load status so that it does not blind other drivers.

Reading light

Button / Switch	Function
0	Switching off the reading light.
☀	Switching on the reading light.
🗨	Switches door contact control on (central position). The reading light comes on automatically when the vehicle is unlocked, a door is opened or the key is removed from the ignition. The light goes off a few seconds after all the doors are closed, the vehicle is locked or the ignition is switched on.



Note

The reading lights go out when the vehicle is locked, or a few minutes after the key is removed from the ignition. This prevents the battery from discharging.

Sun blind

Introduction

WARNING

Folded sun blinds can reduce visibility.

- Always roll or fold sun blinds and visors away when not in use.

Options for adjusting driver and front passenger sun visors:

- Lower by unfolding towards the windscreen.
- The sun visor can be pulled out of its mounting and turned towards the door.
- Swing the sun visor towards the door, longitudinally backwards.

Vanity mirror*

There may be a vanity mirror in the folded sun visor on the passenger side and a cardholder in the driver sun visor.

Sun visors

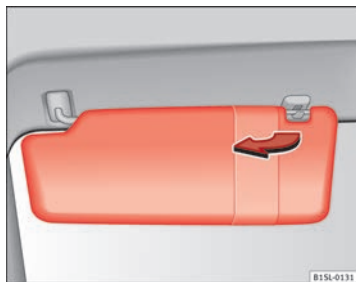


Fig. 58 Sun visor

Heat-insulating glass windscreen

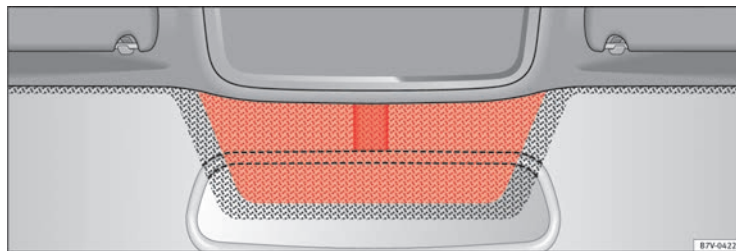


Fig. 59 Windscreen with reflective infrared and metal coating and small window (red surface)

The heat-insulating windscreens include a reflective infrared coating. The section above the rear vision mirror has been left uncoated (communication window) to allow electric components from the accessories shop to operate correctly → Fig. 59.

⚠ CAUTION

When the uncoated surface is covered or has a sticker on the interior or exterior, malfunctions in the electronic components may occur. Never cover the uncoated surface on the interior or exterior. ■

Window wash/wipe system

Introduction

Additional information and warnings:

- Exterior detail ⇒ page 6
- Air recirculation mode ⇒ page 164
- Working in the engine compartment ⇒ page 180
- Caring for and cleaning the vehicle exterior ⇒ page 197

WARNING

Water from the windscreen washer water bottle may freeze on the windscreen if it does not contain enough anti-freeze, reducing forward visibility.

- In winter, ensure the windscreen washer contains enough anti-freeze.
- In cold conditions, you should not use the wash / wipe system unless you have warmed the windscreen with the ventilation system. The anti-freeze could freeze on the windscreen and reduce visibility.

WARNING

Worn or dirty wiper blades reduce visibility and increase the risk of accident and serious injury.

- Always replace damaged or worn blades or blades which do not clean the windscreen correctly.

CAUTION

In icy conditions, always check that the wiper blades are not frozen to the glass **before** using the windscreen wipers for the first time. In cold weather, it may help to leave the vehicle parked with the windscreen wipers in service position ⇒ page 93.

Windscreen wiper lever

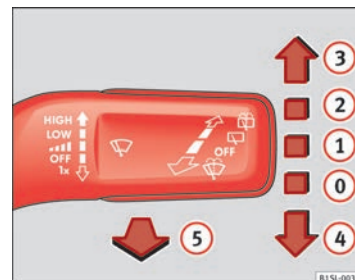


Fig. 60 Using the windscreen wipers

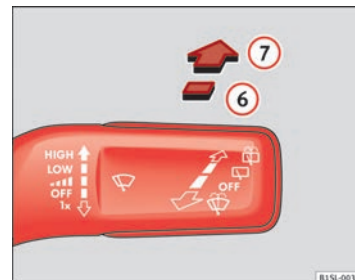






Fig. 61 Using the rear window wipers

Move the lever to the required position ⇒ ⓘ:

①	OFF	Windscreen wiper off.
①		Windscreen interval wipe.
②	LOW	Slow wipe.
③	HIGH	Continuous wipe.
④	1x	Brief wipe - short wipe. Hold the lever down for more time to increase the wipe frequency.
⑤		Automatic wipe for cleaning windcreens with the lever up.
⑥		Interval wipe for rear window. The wiper will clean the window approximately every 6 seconds.
⑦		Automatic wipe for cleaning rear windows with the lever pressed.

ⓘ CAUTION

If the ignition is switched off while the windscreen wipers are on, the windscreen wipers carry on wiping at the same level when the ignition is switched back on. Ice, snow and other obstacles may damage the windscreen wiper and the wiper motor.

- If necessary, remove snow and ice from the windscreen wipers before starting your journey.
- Carefully lift the frozen windscreen wipers from the glass. SEAT recommends a de-icer spray for this operation.

ⓘ Note

The windscreen wipers will only work when the ignition is switched on.

ⓘ Note

The interval wipe speed varies according to the vehicle speed. The faster the vehicle is moving, the more often the windscreen is cleaned.

ⓘ Note

The rear wiper is automatically switched on when the windscreen wiper is connected and the vehicle is in reverse gear. ■

Windscreen wiper functions

Windscreen wiper performance in different situations:

If the vehicle is at a standstill: The activated position provisionally changes to the previous position.

For the interval wipe: The intervals between wipes vary according to the speed of the vehicle. The higher the vehicle speed the shorter the intervals.

ⓘ Note

The windscreen wiper will try to wipe away any obstacles that are on the windscreen. The windscreen wiper will stop moving if the obstacle blocks its path. Remove the obstacle and switch the windscreen wiper back on again. ■

Windscreen wipers service position

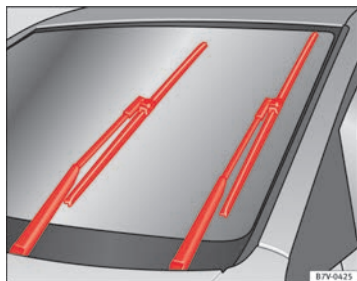


Fig. 62 Windscreen wipers in service position

The wiper arms can be raised when the wipers are in service position ⇒ Fig. 62. To place the windscreen wipers in the service position, proceed as follows:

- The bonnet must be closed ⇒ page 180.
- Switch the ignition on and off.
- Press the windscreen wiper lever downwards briefly ⇒ Fig. 60 ④.

Before driving, always lower the wiper arms. When the ignition is switched on, the windscreen wiper arms return to their initial position upon activating the windscreen wiper lever.

Lifting and returning windscreen wiper arms

- Place the windscreen wiper arms in the service position ⇒ ④.
- Only hold the windscreen wiper arms at the point where the blade is fixed.

⚠ CAUTION

- To prevent damage to the bonnet and the windscreen wiper arms, only leave them in the service position.
- Before driving, always lower the windscreen wiper arms. ■

Checking and topping up the windscreen washer bottle with water



Fig. 63 In the engine compartment: windscreen washer bottle top

Check the water level in the windscreen washer bottle regularly and top up as required.

- Open the bonnet Δ ⇒ page 180.
- The washer bottle is marked with the symbol ☞ on the lid ⇒ Fig. 63.
- Check there is enough water in the bottle. ►

- To top up, mix water with a window cleaner recommended by SEAT ⇒ ⓘ. Please follow the instructions for use found on the packaging.
- In cold weather, a special antifreeze should also be added to prevent the water from freezing ⇒ ⚠.

Bottle capacity

The washer bottle capacity is approximately 3 litres.



WARNING

Never mix an unsuitable antifreeze or other similar products with the windscreen washer water. A greasy layer may be formed on the windscreen which will impair visibility.

- Use clean water with a window cleaner recommended by SEAT.
- If necessary, add a suitable antifreeze to the water bottle.



CAUTION

- Do not mix cleaning products recommended by SEAT with other products. This could lead to flocculation and may block the windscreen washer jets.
- When topping up service fluids, make absolutely certain that you fill the fluids into the correct reservoirs. Using the wrong fluids could cause serious malfunctions and engine damage! ■

Rear vision mirror

Introduction

Additional information and warnings:

- Exterior detail ⇒ page 6
- Braking, stopping and parking ⇒ page 134

Rear vision mirror

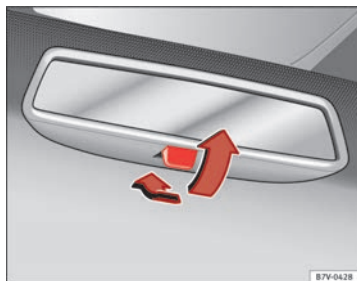


Fig. 64 Manual anti-dazzle function for rear vision mirror

The driver should always adjust the rear vision mirror to permit adequate visibility through the rear window.

Manual anti-dazzle function for rear vision mirror

- Basic position: point the lever at the bottom of the mirror forwards.
- Pull the lever to the back to select the anti-dazzle function ⇒ Fig. 64.

Exterior mirrors

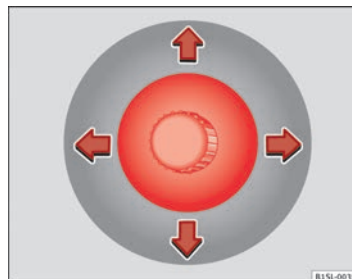


Fig. 65 In the front doors: button to adjust the mechanical exterior rear vision mirror

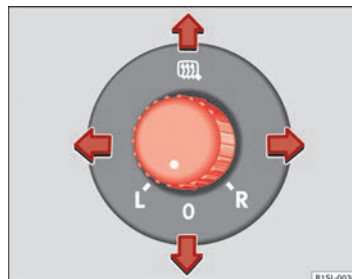


Fig. 66 In the driver door: rotary control for the exterior electric mirrors

Adjust the exterior mirrors by pressing the adjust button ⇒ Fig. 65 or the rotary control* ⇒ Fig. 66.

Turn the rotary control ⇒ Fig. 66 to the required position:

Switch on the exterior mirror heating.

L

Adjust the left-hand exterior rear vision mirror by turning the knob forwards, backwards, to the left or to the right.

0

Zero position. Exterior mirror heating switched off, it is not possible to adjust the exterior mirrors.

R

Adjust the right-hand exterior rear vision mirror by turning the knob forwards, backwards, to the left or to the right.

Folding in the exterior mirrors and returning them to their original position is possible through a mechanical system. Carefully fold the exterior rear vision mirror casing towards the side window or pull it away from the window until it clicks into place.

**WARNING**

Fold and unfold the exterior rear vision mirror, taking care to avoid injuries.

- Only fold or unfold the exterior rear vision mirror when there is no one in the way of the mirror.
- When moving the rear vision mirror, take care not to trap fingers between the mirror and the mirror bracket.

**WARNING**

Failure to correctly estimate the distance of the vehicle behind could lead to serious accident.

- Rear-view convex or aspheric mirrors increase the field of vision, however objects appear smaller and further away in the mirrors.
- The use of these mirrors to estimate the distance to the next vehicle when changing lane is imprecise and could result in serious accident.

**WARNING (Continued)**

- If possible, use the rear vision mirror to estimate distances to vehicles behind you or in other circumstances.
- Make sure that the rear visibility is adequate.

**For the sake of the environment**

The exterior mirror heating should be switched off when it is no longer needed. Otherwise, it is an unnecessary fuel consumption.

**Note**

In the event of faults, the electric exterior mirrors can be adjusted manually by pressing the edge of the mirror surface. ■

Transporting

Driving tips

Introduction

Always transport heavy loads in the luggage compartment and place the seat backs in a vertical position. Never overload the vehicle. Both the carrying capacity as well as the distribution of the load in the vehicle have effects on the driving behaviour and braking ability ⇒ ⚠.

Additional information and warnings:


- Rear lid ⇒ page 40
- To lower the front passenger seat backrest ⇒ page 55
- Light ⇒ page 84
- Luggage compartment ⇒ page 100
- Roof carrier ⇒ page 104
- Wheels and tyres ⇒ page 210

WARNING

Unsecured or incorrectly secured objects can cause serious injury in case of a sudden manoeuvring or braking or in case of an accident. This is especially true when objects are struck by a detonating airbag and fired through the vehicle interior. To reduce the risks, please note the following:

- Secure all objects in the vehicle. Always keep equipment and heavy objects in the luggage compartment.

WARNING (Continued)

- Always secure objects with suitable rope or slings so that they cannot enter the deployment areas around the frontal or side airbags in case of sudden braking or an accident.
- Always ensure that objects inside the vehicle cannot move into the deployment area of the bags while driving.
- While driving, always keep object compartments closed.
- Remove all objects from the front passenger seat when this is folded down. When the seat backrest is folded down, it presses on small and light objects and these are detected by the weight sensor on the seat; this sends false information to the airbag control unit.
- While the backrest of the front passenger seat is folded, the frontal airbag must remain disconnected and the **PASSENGER AIRBAG OFF**  light on.
- Objects secured in the vehicle should never be placed in such a way as to make passengers sit in an incorrect position.
- If secured objects occupy a seat then this should not be occupied or used by anybody.

WARNING

The driving behaviour and braking ability change when transporting heavy and large objects.

- Adjust your speed and driving style to visibility, road, traffic and weather conditions.
- Accelerate gently and carefully.
- Avoid sudden braking and manoeuvres.
- Brake early.

Transporting a load

Secure all objects in the vehicle

- Distribute the load throughout the vehicle and on the roof as uniformly as possible.
- Transport heavy objects as far forward as possible in the luggage compartment and lock the seat backs in the vertical position.
- Check the headlight adjustment ⇒ page 84.
- Use the suitable tyre pressure according to the load being transported. Read the tyre pressure information label ⇒ page 210.



CAUTION

Objects on the shelf could chafe against the wires of the heating element in the heated rear window and cause damage.



Note

Please refer to the notes on loading the roof carrier ⇒ page 104.

Driving with the rear lid open

Driving with the rear lid open creates an additional risk. Secure all objects and secure the rear lid correctly and take all measures possible to reduce toxic gases from entering the vehicle.



WARNING

Driving with the rear lid unlocked or open could cause serious injuries.

- Always drive with the rear lid closed.



WARNING (Continued)

- Secure all objects in the vehicle. Loose items could fall out of the vehicle and injure other road users or damage other vehicles.
- Drive particularly carefully and think ahead.
- Avoid sudden manoeuvres and braking given that this could cause an uncontrolled movement of the open rear lid.
- When transporting objects that protrude out of the luggage compartment, indicate them suitably. Observe legal requirements.
- If objects must project out of the luggage compartment, the rear lid must never be used to “secure” or “attach” objects.
- If a baggage rack is fitted on the rear lid, it should be removed before travelling with the rear lid open.



WARNING

Toxic gases may enter the vehicle interior when the rear lid is open. This could cause loss of consciousness, carbon monoxide poisoning, serious injury and accidents.

- To avoid toxic gases entering the vehicle always drive with the rear lid closed.
- In exceptional circumstances, if you must drive with the rear lid open, observe the following to reduce the entry of toxic gases inside the vehicle:
 - Close all windows.
 - Disable air recirculation mode.
 - Open all of the air outlets on the instrument panel.
 - Switch on the blower to maximum.



CAUTION

An open rear lid changes the length and height of the vehicle.

Driving a loaded vehicle

For the best handling when driving a loaded vehicle, note the following:

- Secure all objects ⇒ page 98.
- Accelerate gently and carefully.
- Avoid sudden braking and manoeuvres.
- Brake early.
- If necessary, read the instructions for driving with a roof carrier system ⇒ page 104.



WARNING

A sliding load could considerably affect the stability and safety of the vehicle resulting in an accident with serious consequences.

- Secure loads correctly so they do not move.
- When transporting heavy objects, use suitable ropes or straps.
- Lock the seat backs in vertical position.

Loading luggage compartment

Introduction

Always transport heavy loads in the luggage compartment and place the seat backs in a vertical position. Never overload the vehicle. Both the carrying capacity as well as the distribution of the load in the vehicle have effects on the driving behaviour and braking ability ⇒ ⚠.

Additional information and warnings:

- Airbag system ⇒ page 67
- Light ⇒ page 84
- Transporting ⇒ page 97
- Wheels and tyres ⇒ page 210



WARNING

When the vehicle is not in use or being watched, always lock the doors and the rear lid to reduce the risk of serious injury or death.

- Do not leave children unwatched, especially when the rear lid is open. Children could climb into the luggage compartment, close the rear lid from inside and be unable to escape themselves. This could lead to serious injury or death.
- Never allow children to play in or around the vehicle.
- Never transport people in the luggage compartment.



WARNING

Unsecured or incorrectly secured objects can cause serious injury in case of a sudden manoeuvring or breaking or in case of an accident. This is especially true when objects are struck by a detonating airbag and fired through the vehicle interior. To reduce the risks, please note the following:

- Secure all objects in the vehicle. Always keep equipment and heavy objects in the luggage compartment.
- Always secure objects with suitable rope or straps so that they cannot enter the deployment areas around the frontal or side airbags in case of sudden braking or an accident.
- While driving, always keep object compartments closed.
- Do not place hard, heavy or sharp objects inside the interior, in open storage compartments, the rear shelf or on the dash panel.
- Remove hard, heavy and sharp objects from clothes and pockets inside the vehicle and store securely.



WARNING

The transport of heavy object changes vehicle handling and increases braking distance. Heavy loads that have not been stored or secured correctly could cause loss of control and result in serious injury.

- The vehicle handling changes when transporting heavy objects due to a change in the centre of gravity.
- Distribute the load as uniformly and as low down on the vehicle as possible.
- Store heavy objects in the luggage compartment as far from the rear axle as possible.



CAUTION

Hard objects on the rear shelf could chafe against the wires of the heating element in the heated rear window and cause damage. ▶

Note

The ventilating slits between the heated rear window and the rear shelf must not be covered so that used air can escape from the vehicle.

Folding and lifting up the rear seat backrest

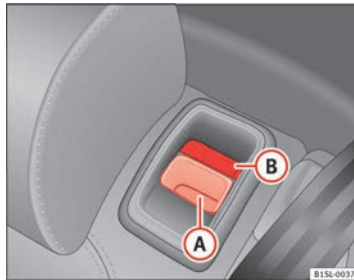



Fig. 67 Rear seat: unlock button (A); red marking (B)

The rear seat backrest can be folded forward to extend the luggage compartment.

Folding the rear seat backrest forwards

- Push the head restraint down as far as it will go or remove it if necessary ⇒ page 48 and store it in a safe place.
- Pull the unlock switch ⇒ Fig. 67 (A) forwards whilst simultaneously lifting the rear seat backrest.
- The rear seat backrest is not engaged when the red marking of the button (B) is visible.
- If the rear seat backrest is folded, people (including children) are not permitted to travel in the rear folded seats.

Folding up the rear seat backrest

- Lift back the backrest of the rear seat and push it firmly into the lock until it clicks securely into place ⇒ .
- The red marking on the unlock button (B) must not be seen.
- Make sure that the backrest of the rear seat is securely locked in position so that the seat belts can provide proper protection in the rear seats.
- If necessary, install and adjust the head restraints again ⇒ page 48.

WARNING

Folding and lifting the backrests of the rear seats carelessly without paying attention could cause serious injury.

- Never fold or lift the seats while driving.
- Do no trap or damage seat belts when raising the backrest.
- Keep hands, fingers, feet and other limbs away from the range of the rear seat backrests when folding and lifting them.
- All backrests must engage correctly for the seat belts on the rear seats to work properly. When the backrest of an occupied seat is not correctly locked in place, the passenger can be thrust forward with the rear seat backrest in case of sudden braking, sudden manoeuvres or an accident.
- A red signal on the button (B) warns that the backrest is not engaged. Always check that the red marking is not visible when the backrest of the rear seat is in the upright position.
- No seat must be occupied if the backrest of the rear seat is folded or not correctly engaged.

CAUTION

Before folding the backrest of the rear seat, adjust the front seats so that the head restraint or backrest do not hit them when it is folded. If necessary, remove the head restraints ⇒ page 48 and store them safely.

Rear shelf*

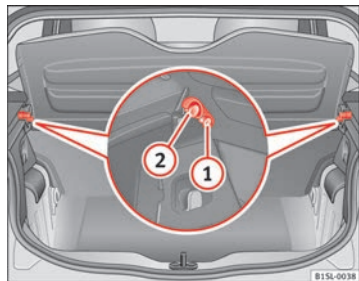


Fig. 68 In the luggage compartment: removing and installing the rear shelf

You may put light items of clothing on the rear shelf. Check that the rear view is not limited.

Lifting up the rear shelf

Lift up the rear shelf and secure it into the side locks → Fig. 68 ①. Check that it is correctly engaged. To lower the rear shelf, press it until it is released from the locks.

Removing the shelf

Pull the rear shelf upwards, removing it from the side supports ②.

Lifting up the rear shelf

Press the rear shelf downwards into the side supports ②.



WARNING

Unsecured or incorrectly secured objects or animals on the rear shelf could cause serious injuries in case of a sudden manoeuvre or braking or even an accident.

- Do not leave hard, heavy or sharp objects (loose or in bags) on the rear shelf.
- Never transport animals on the rear shelf.
- Never drive with the rear shelf raised. Always lower it or remove it before the journey.



CAUTION

To prevent the rear shelf from being damaged:

- Always check that the rear shelf is firmly engaged into the side supports.
- Regulate the height of the load in the luggage compartment to ensure the rear shelf does not press down on the load with the rear lid closed. ■

Fastening rings*

In the front part of the luggage compartment, there may be fastening rings to secure the luggage.

In order to use the fastening rings, they must be lifted beforehand. ►

⚠ WARNING

If unsuitable or damaged belts or retaining straps are used, they could break in the event of braking or an accident. Objects could then be launched across the passenger compartment and cause serious or fatal injuries.

- It is important to always use belts or retaining straps that are suitable and in a good condition.
- Belts and retaining straps should be securely fastened to the fastening rings.
- Objects in the luggage compartment that are unsecured could move suddenly and modify the handling of the vehicle.
- Small and light objects must also be secured.
- The maximum tensile load of the fastening ring for securing objects should never be exceeded.
- A child seat should never be secured with the fastening rings.

i Note

- The maximum tensile load that the fastening rings can support is 3.5 kN.
- Belts and securing systems for the appropriate load can be obtained from specialised dealerships. SEAT recommends visiting a SEAT dealership for this.

Retaining hooks

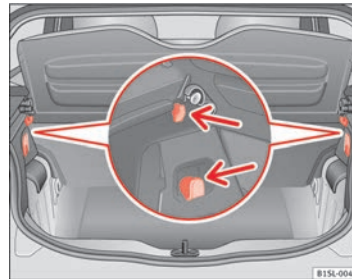


Fig. 69 In the luggage compartment: retaining hooks

There may be hooks in the upper left and right part of the luggage compartment.

⚠ WARNING

Never use these hooks to secure objects. In case of sudden braking or an accident, the hooks could rupture.

⚠ CAUTION

The hooks can support a maximum of 2.5 kg individually.

Roof carrier system

Introduction

The vehicle roof has been designed to optimise aerodynamics. For this reason, conventional roof carrier systems cannot be secured to the water drains.

Given that the water drains have been incorporated into the roof for aerodynamic reasons, only the SEAT approved basic supports and roof carrier systems can be used.

When the roof carrier system should be removed:

- When it is not being used.
- When the vehicle is being washed in a car wash.
- When the vehicle height exceeds the maximum height, for example, in a garage.

Additional information and warnings:

- Light ⇒ page 84
- Transporting ⇒ page 97
- Ecological driving ⇒ page 144
- Wheels and tyres ⇒ page 210
- Accessories, parts replacement, repairs and modifications ⇒ page 222



WARNING

The risk of an accident is increased by transporting heavy or bulky loads on the roof, which affects the vehicle's handling by shifting the centre of gravity and increasing susceptibility to cross winds.

- Always secure loads correctly with suitable and undamaged attachment rope or straps.
- Large, heavy, wide and flat loads negatively affect the vehicle aerodynamics, centre of gravity and handling.
- Avoid brusque manoeuvres and sudden braking.
- Adjust your speed and driving style to visibility, road, traffic and weather conditions.



CAUTION

- Always remove the roof carrier system from the roof before entering a car wash.
- The height of your vehicle is changed by the installation of the roof carrier and the load secured on it. Compare the vehicle height with the passage height, for example in underground car parks or entering garage doors.
- The roof antenna and the range of the rear lid should not be affected by the roof carrier system and the load being transported.
- Take extra care not to let the rear lid strike the roof load when opening.



For the sake of the environment

The vehicle uses more fuel when the roof carrier system is fitted. ■

Securing the base supports and roof carrier system

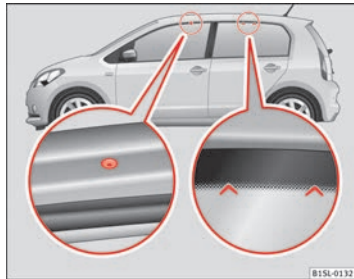


Fig. 70 Attachment points for the basic support and the roof carrier system

The mounts are the basis of a complete roof carrier system. Special fixtures must then be added in order to safely transport luggage, bicycles, skis, surfboards or boats on the roof. The suitable accessories can be acquired at SEAT dealerships.

Securing the base supports and roof carrier system

The roof carrier system must always be installed exactly according to the instructions provided.

The front attachment opening can be found in the lower part of the sides of the roof and are fixed with plastic bolts → Fig. 70 (left magnified image). The openings can only be seen with the door open. The markings for attachment in the lower part are found in the upper part of the rear side windows → Fig. 70 (right magnified image).

The base support should **only** be fitted to the points indicated in the diagram.

WARNING


If the base supports and the roof carrier system are incorrectly fitted or used in an unsuitable manner, the entire system could break free causing accident and injury.

- Always take the manufacturer assembly instructions into account.
- Only use base supports and roof carrier systems that are not damaged and are correctly fitted.
- The base support should only be fitted to the points indicated in the diagram → Fig. 70.
- Secure the base supports and roof carrier system correctly.
- Check the screw fittings and attachments before driving and after a short distance. During each long journey, check the attachments during every break.
- Always fit the roof carrier system correctly for wheels, skis and surfboards, etc.
- **Never change or repair the basic supports or roof carrier system.**


Note

Read and take into account the instructions included with the roof carrier system fitted and keep them in the vehicle. ■

Loading the roof carrier system

Loads can only be correctly secured when the roof carrier system is correctly fitted → .

Maximum authorised roof load

The maximum authorised roof load is **50 kg**. The roof load includes the weight of the base support, the roof carrier system and the load being transported →  ▶

Always check the weight of the base support, the roof carrier system and the weight of the load to be transported and, if necessary, weigh them. Never exceed the maximum authorised roof load.

If you are using a roof carrier with a lower weight rating, you cannot transport the maximum roof load. Do not exceed the maximum weight limit for the roof carrier given in the fitting instructions.

Distributing a load

Uniformly distribute loads and secure them correctly ⇒ .

Check attachments

After fitting the base supports and the roof carrier system, always check the attachments after a short trip or at regular intervals.



WARNING

Exceeding the maximum authorised roof load can result in accidents and/or vehicle damage.

- Always respect the maximum authorised weight for the roof, the maximum authorised weight on the axles and the total maximum authorised weight of the vehicle.
- Never exceed the capacity of the roof carrier system even if this is less than the maximum authorised roof load.
- Secure heavy objects towards the front and distribute the load evenly.



WARNING

Loose and incorrectly secured loads can fall from the roof carrier system causing accidents and injury.

- Always use suitable ropes and straps in good condition.
- Always secure loads correctly.

Trailer coupling

Information about trailer coupling

The vehicle is **not** certified for trailer coupling. The vehicle is not equipped in the manufacture with a towing bracket, nor is it possible to retrofit a towing bracket.

WARNING

Installing a towing bracket on the vehicle may cause accidents and serious injuries while operating the vehicle.

- Never install a towing bracket on the vehicle.
- The trailer may be released from the vehicle when the vehicle is moving.

CAUTION

Any type of towing bracket installed on the vehicle can cause serious and costly damage that are not covered under the SEAT guarantee. ■

Practical equipment

Storage compartments

Introduction

Storage compartments must only be used to store light or small objects.

Additional information and warnings:

- Care and cleaning of the vehicle interior ⇒ page 205
- ⇒ Booklet Radio system



WARNING

In the event of sudden braking movements or turns, loose objects may be thrown around the vehicle interior. This could cause serious injuries to passengers and cause the driver to lose control of the vehicle.

- Do not transport animals or place hard, heavy or sharp objects in the interior of the vehicle in: open storage compartments, dash panel, storage tray, items of clothing or bags.
- While driving, always keep object compartments closed.



WARNING

Objects falling into the driver's footwell could prevent use of the pedals. This could lead the driver to lose control of the vehicle, increasing the risk of a serious accident.

- Make sure the pedals can be used at all times, with no objects rolling underneath them.
- The floor mat should always be secured to the floor.



WARNING (Continued)

- Never place other mats or rugs on top of the original mat supplied by the factory.
- Make sure that no objects can fall into the driver's footwell while the vehicle is in motion.



CAUTION

- Objects on the shelf could chafe against the wires of the heating element in the heated rear window and cause damage.
- Do not keep temperature-sensitive objects, food or medicines inside the vehicle. Heat and cold could damage them or render them useless.
- Light-transparent objects placed inside the vehicle, such as lenses, magnifying glasses or transparent suction caps on the windows, could concentrate the sun's rays and cause damage to the vehicle.



Note

The ventilating slits between the heated rear window and the rear shelf must not be covered so that used air can escape from the vehicle. ■

Storage compartment on the driver side



Fig. 71 On the driver side: storage compartment

There may be a storage compartment on the driver side.

WARNING

In the event of sudden braking movements or turns, loose objects may be thrown around the vehicle interior. This could cause serious injuries to passengers and cause the driver to lose control of the vehicle.

- Do not leave animal or objects of a material that is hard, heavy or sharp in the open storage compartment.

Compartment on the centre console



Fig. 72 In the front part of the centre console: storage compartment

The storage compartment ⇒ **Fig. 72** may be used as a drink holder ⇒ page 113 or as an ashtray* ⇒ page 115 or to store small objects.

Note

A 12 volt electrical socket ⇒ page 118 can be found in the storage compartment.

Storage compartment with cover on the passenger side*

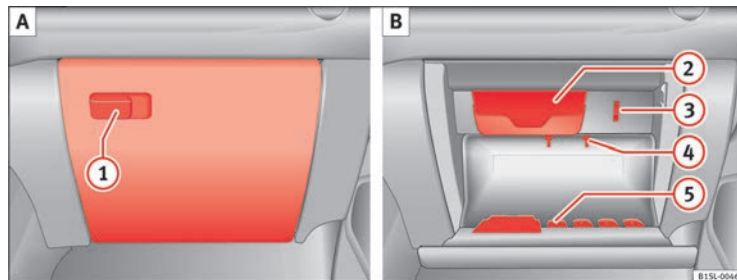


Fig. 73 Storage compartment with cover on the passenger side

There may be a storage compartment with cover on the passenger side.

Opening and closing the storage compartment cover

Pull the lever to *open* ⇒ Fig. 73 ①.

To *close*, press the cover upwards until it clicks into place.

Sunglasses storage compartment.

Sunglasses can be stored in the passenger side storage compartment.

The sunglasses storage compartment is in the upper area of the storage compartment ②.

Supports

Next to the sunglasses storage compartment is a notebook holder ③ and in the interior of the storage compartment there is a pen holder ④, a map storage area and a purse ⑤.



WARNING

The risk of serious injuries in the event of an accident during a sudden braking manoeuvre or turn is increased if the storage compartment is left open.

- Keep the storage compartment closed while the vehicle is in motion.



CAUTION

For structural reasons, some model versions will have gaps behind the glove compartment into which small objects may fall. This could lead to strange noises and damage to the vehicle. Therefore, do not store small objects in the storage compartment, apart from those stored in the spaces provided.

Open storage compartment on the passenger side*

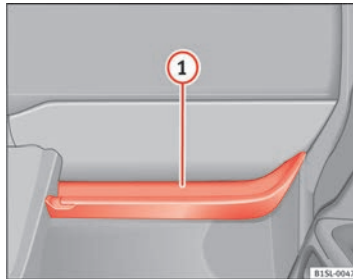


Fig. 74 Open storage compartment on the passenger side

There may be an open storage compartment on the passenger side.

Support

In the open storage compartment there is a hook for bags ⇒ Fig. 74 ①.

WARNING

In the event of sudden braking movements or turns, loose objects may be thrown around the vehicle interior. This could cause serious injuries to passengers and cause the driver to lose control of the vehicle.

- Do not leave animal or objects of a material that is hard, heavy or sharp in the open storage compartment.

Storage compartment in the back of the centre console

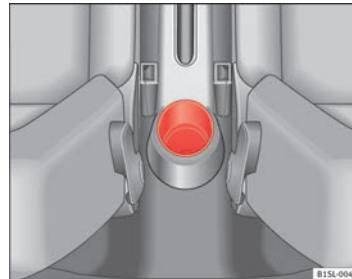


Fig. 75 In the back part of the centre console: storage compartment

The drink holder in the back part of the centre console ⇒ page 113 can be used as a storage compartment.

Other storage compartments



Fig. 76 In front of the rear seats: storage compartment

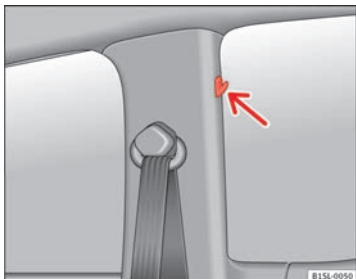


Fig. 77 In the centre pillars: coat hooks

Coat hooks

In the centre pillars there are coat hooks ⇒ Fig. 77 (arrow).

Other storage compartments:

- In the front door trims ⇒ page 9.
- In front of the rear seats ⇒ Fig. 76.
- Rear shelf for light items of clothing*.
- Bag hook in the luggage compartment ⇒ page 100.
- In the upper part of the centre console, in place of the radio ⇒ Fig. 6 5).



WARNING

Clothing hung on the coat hooks could restrict the driver's view and lead to serious accidents.

- Hang the clothes from the hooks so that driver's view is not restricted.
- The coat hook is suitable for light items of clothing. Never place heavy, hard or sharp objects in the bags.

Drink holders

Introduction

Drink holders

The drink holders are in the open storage compartments in the driver and passenger doors.

Additional information and warnings:

- Care and cleaning of the vehicle interior ⇒ page 205



WARNING

Improper use of the drink holders can cause injury.

- Do not place containers with hot drinks in a drink holder. During sudden braking or driving manoeuvres, the hot drink could be spilled and lead to scalding.
- Ensure that bottles and other object is dropped in the driver footwell, as it could get under the pedals and obstruct their working.
- Never place heavy containers, food or other heavy objects in the drink holder. In the event of an accident, these heavy objects could be thrown around the interior and cause serious injuries.



WARNING

Closed bottles inside the vehicle could explode or crack due to the heat or the cold.

- Never leave a closed bottle in the vehicle if the inside temperature is too high or too low.



CAUTION

Do not leave open drinks containers in the drink holders when the vehicle is in motion. They could spill during braking, for example, and cause damage to the vehicle and the electrical system.

Centre console drink holders

Place the drink container in the drink holder so that it surrounds it securely. ■



Fig. 78 In the front part of the centre console: drink holder

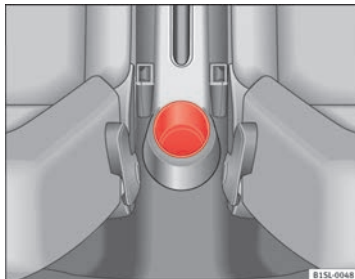


Fig. 79 In the back part of the centre console: drink holder

There are drink holders in the front and rear parts of the centre console.

Securing the drink container in the front drink holder

Fold the drink holder ⇒ Fig. 78 forward.

Ashtray and Lighter

Introduction

Additional information and warnings:

- Power socket ⇒ page 117
- Accessories, parts replacement, repairs and modifications ⇒ page 222



WARNING

Undue use of the ashtray and cigarette lighter may cause a fire or burns and other serious injuries.

- Never put paper or other flammable objects in the ashtray. ■

Ashtray*



Fig. 80 In the front part of the centre console: Opening the ashtray

Opening and closing the ashtray

To *open*, lift the lid of the ashtray in the direction of the arrow ⇒ Fig. 80.

To *close*, push the ashtray lid down.

Emptying the ashtray

- Remove the ashtray from the storage compartment lifting it up.
- After emptying the ashtray, insert it into the drink holder from above. ■

Cigarette lighter*



Fig. 81 In the front part of the centre console: lighter

- Push the button on the cigarette lighter inwards with the ignition on ⇒ Fig. 81.
- Wait for the cigarette lighter to pop out slightly.
- Pull out the cigarette lighter and light the cigarette on the glowing coil ⇒ ⚠.
- Replace the cigarette lighter in its insert. ▶

**WARNING**

Undue use of the cigarette lighter may cause a fire or burns and other serious injuries.

- The cigarette lighter must only be used to light cigarettes or similar.
- Never leave children unsupervised in the vehicle. The cigarette lighter can be used when the ignition is switched on.

**Note**

The cigarette lighter can also be used with the 12 Volt socket. ■

Electrical power socket*

Introduction

Electrical equipment can be connected to the socket in the vehicle.

Connected equipment must be in perfect condition and show no signs of faults.

Additional information and warnings:

- Cigarette lighter ⇒ page 115
- Accessories, parts replacement, repairs and modifications ⇒ page 222

WARNING

Improper use of the socket or electrical devices could lead to a fire and cause serious injuries.

- **Never leave children unsupervised in the vehicle. The socket and equipment connected to it can be used when the ignition is switched on.**
- **Should a connected electrical device overheat, switch it off and unplug it immediately.**

CAUTION

- To avoid damage to the vehicle's electrical system, never connect equipment that generates electrical current, such as solar panels or battery chargers, to the 12 Volt sockets in order to charge the vehicle's battery.
- Only use accessories with approved electromagnetic compatibility according to current regulations.

- To avoid damage due to voltage variations, switch off all appliances connected to the 12 V socket before switching the ignition on or off and before starting the engine.
- Never connect an appliance to the 12 Volt socket that consumes more than the power indicated in watts. Exceeding the maximum power absorption could damage the vehicle's electrical system.



For the sake of the environment

Do not leave the engine running when the vehicle is at a standstill.



Note

Using electrical appliances with the engine stopped and the ignition switched on will drain the battery.



Note

Unshielded equipment can cause interference on the radio system equipment and the vehicle's electrical system.



Note

If electrical equipment is used near an aerial, you may observe interference in the reception of AM stations.

Vehicle socket



Fig. 82 Front centre console: 12 Volt socket in the storage compartment

Maximum power consumption

Socket	Maximum power consumption
12 Volts	120 Watts

The maximum capacity of the socket must not be exceeded. The power consumption is indicated on the rating plate of each appliance.

Where 2 or more appliances are connected at the same time, the total rating of all the connected devices must never exceed 190 Watts → ⚠.

12 volt socket

The 12 volt socket is found in the storage compartment in the front part of the centre console → Fig. 82 and only functions when the ignition is switched on.

Using electrical appliances with the engine stopped and the ignition switched on will drain the battery. Therefore, electrical consumers connected to the socket must only be used when the engine is running.

To prevent voltage variations from causing damage, switch off the electrical consumer connected to the 12 Volt socket before switching the ignition on or off and before starting the engine.

⚠ CAUTION

- Always follow the operating instructions for the appliances to be connected!
- Never exceed the maximum power rating as this could damage the vehicle's general electrical system.
- **12 volt socket:**
 - Only use accessories with approved electromagnetic compatibility according to current regulations.
 - Never power the socket.

While driving

Starting, changing gears, parking

Stopping and starting the engine

Introduction

Immobilizer display

When an invalid key is used or in the event of a system fault, **SAFE** is displayed on the instrument panel. The engine cannot be started.

Pushing or towing

For technical reasons, the vehicle must **not** be push- or tow-started. Jump starting is preferable.

Additional information and warnings:

- Vehicle key set ⇒ page 28
- Changing gear ⇒ page 124
- Braking, stopping and parking ⇒ page 134
- Steering ⇒ page 147
- Refuelling ⇒ page 171
- Fuel ⇒ page 177
- Emergency locking and unlocking ⇒ page 243
- Jump starting ⇒ page 273
- Tow-starting and towing away ⇒ page 276



WARNING

Switching off the engine while driving makes stopping the vehicle difficult. As a consequence you may lose control of the vehicle and there is a risk of serious accident.

- The assisted braking and steering systems, the airbag system, safety belts and certain safety equipment are only active while the engine is running.
- The engine should only be switched off when the vehicle is at a standstill.



WARNING

While the engine is running or starting it could help reduce the risk of serious injury.

- Never start or leave the engine running in poorly ventilated or closed spaces. Exhaust gas contains carbon monoxide, a toxic, colourless and odourless gas. Carbon monoxide can cause people to lose consciousness. It can also cause death.
- Never leave the vehicle unattended if the engine is running. The vehicle could move off suddenly or something unexpected could happen resulting in damage and serious injury.
- Never use start boosters. Cold start sprays could explode or increase the engine speed unexpectedly.

⚠ WARNING

The components of the exhaust system reach very high temperatures. This could cause a fire and considerable damage.

- Always park your vehicle so that no part of the exhaust system can come in contact with flammable materials (such as wood, leaves, spilled fuel, dried grass, etc).
- Never apply additional underseal or anti-corrosion coatings to the exhaust pipes, catalytic converter or the heat shields on the exhaust system.

Ignition lock



Fig. 83 Vehicle key positions

Vehicle keys ⇒ Fig. 83

No key in the ignition lock: The steering lock may be activated.

- ① Ignition switched off. Key can be removed from the vehicle.
- ② Ignition is switched on. The steering lock can be unlocked.
- ③ Switch on the engine. Release the key when the engine has started. When it is released, the key returns to position ①.

Key not authorised for the vehicle

If a key which is not authorised for this vehicle is inserted in the ignition lock, it can be removed as follows:

- *Automatic gearbox*: the key cannot be removed from the ignition lock. Press and release the selector lever locking button. Key can be removed from the vehicle.
- *Manual gearbox*: Remove the key from the ignition.

! WARNING

Unsuitable or careless use of the vehicle key could result in serious injury.

- Always take all the keys with you whenever you leave the vehicle. The engine could accidentally be started and electrical equipment such as the windows could accidentally be operated resulting in serious injury.
- Never leave children or disabled people alone in the vehicle. They could be trapped in the vehicle in an emergency and will not be able to get themselves to safety. For example, depending on the time of the year, temperatures inside a locked and closed vehicle can be extremely high or extremely low resulting in serious injuries and illness or even death, particularly for young children.
- Never remove the key from the ignition if the vehicle is in motion. The steering may lock and it will not be possible to turn the steering wheel.

**Note**

- If the key is left in the ignition lock with the engine off for long periods, the vehicle battery will run flat.
- For **automatic gearbox vehicles** the key can only be removed from the ignition lock if the gear selector lever is in position **P**. In this case, press and release the selector lever locking button. ■

Starting the engine**Complete operations only in the sequence given.**

1.	Press the brake pedal and keep pressed until step 5 has been completed.
1 a.	In vehicles with a manual gearbox: Press the clutch pedal all the way and keep pressed until the engine starts.

Complete operations only in the sequence given.

2.	Put the gearbox lever in neutral or the selector lever in position P or N .
3.	Turn the key in the ignition lock to position ⇒ Fig. 83 ②; do not press the accelerator.
4.	When the engine has started, release the key in the ignition lock.
5.	If the engine does not start, stop the process and try again after one minute.
6.	Release the handbrake when you want to begin driving ⇒ page 134.

! WARNING

Never leave the vehicle unattended if the engine is running. The vehicle could move off suddenly, especially if it is in gear, resulting in an accident and serious injury.

! WARNING

Cold start sprays could explode or cause a sudden increase in the engine speed.

- Never use start boosters.

**CAUTION**

- An attempt to start the engine while driving or starting the engine immediately after turning it off can cause damage to the engine or starter motor.
- When the engine is cold, avoid high revs and heavy acceleration and do not make the engine work hard.
- Do not push or tow start the engine. Sunburnt fuel could damage the catalytic converter. ▶

**For the sake of the environment**

Do not warm the engine at idle speed; start driving immediately if the visibility is OK. This helps the engine reach operating temperature faster and reduces emissions.

**Note**

Electrical components with a high power consumption are switched off temporarily when the engine starts.

**Note**

When the engine is started cold, there may be strong vibrations for a few moments for technical reasons. This is quite normal, and no cause for concern.

**Note**

Natural gas engines always start up with petrol, as a certain operating temperature is required for running with gas. Once the required operating temperature is reached, the engine will change to operate with natural gas. ■

Stopping the engine**Complete operations only in the sequence given.**

1.	Stopping the vehicle completely ⇒
2.	Press the brake pedal and keep pressed until step 4 has been completed.
3.	In automatic gearboxes, put the selector lever in position P
4.	Apply the handbrake firmly ⇒ page 134.
5.	Turn the key in the ignition lock to position ⇒ Fig. 83
6.	With a manual gearbox, put the vehicle in first or reverse gear.

**WARNING**

Never switch off the engine while the vehicle is moving. You may lose control of the vehicle and there is a risk of serious accident.

- The airbags and belt tensioners do not work when the ignition is switched off.
- The brake servo does not work when the engine is not running. To stop, the brake pedal must be pressed with more force.
- As the power steering does not work if the engine is not running, you will need more strength to steer than normally.
- If the key is removed from the ignition, the steering may lock and it will not be possible to steer the vehicle.

**CAUTION**

If the engine has been driven at high speed for a prolonged period of time, it may overheat when turned off. To avoid engine damage, allow the engine to run for approximately 2 minutes in neutral before switching it off.

**Note**

- In vehicles with automatic gearbox, the key can only be removed when the selector lever is in position **P**.
- After stopping the engine, the engine compartment fan may continue running for a few minutes, even when the ignition has been switched off or the key removed. The radiator fan is automatically switched off. ■

Electronic immobilizer

The gear lock prevents the engine from being started with an unauthorised key and the vehicle being moved.

The vehicle key has a built-in chip. It automatically deactivates the immobilizer when the key is inserted into the ignition lock. ►

The electronic immobilizer will be activated again automatically as soon as you remove the key from the ignition lock.

For this reason, the vehicle can only be used with a genuine SEAT key with the correct code. Coded keys can be obtained from SEAT dealerships
⇒ page 28.

If an unauthorised key is used, the signal **SAFE** appears on the instrument panel display. The vehicle cannot be started in this case.

**Note**

The correct operation of the vehicle is only guaranteed when original SEAT keys are used. ■

Changing gear

Introduction

When reverse gear is engaged and the ignition is switched on the following takes place:

- Reverse lights light up.
- The rear wiper blade performs one movement when the windscreen wiper is activated.
- If necessary, connect the parking distance warning system.

Additional information and warnings:

- Detail of the centre console ⇒ page 12
- Instruments ⇒ page 17
- Braking, stopping and parking ⇒ page 134
- Parking distance warning system ⇒ page 149
- Electronic power control and exhaust gases purification system ⇒ page 236
- Emergency locking and unlocking ⇒ page 243

WARNING

Rapid acceleration can cause loss of traction and skidding, especially on slippery ground. This could cause loss of control of the vehicle resulting in an accident and considerable damage.

- Use rapid acceleration only when visibility, weather, road conditions and traffic permit.




WARNING



Do not allow the brakes to “rub” for a prolonged period of time, or press the brake pedal frequently or for long periods of time. Continuous braking heats up the brakes. This could significantly reduce braking power, increase braking distance or even result in the total failure of the brake system.



CAUTION

- Never make the brakes “slip” by pressing the pedal gently, if it is not really necessary to brake. This will increase wear.
- Reduce speed or reduce the gear when faced with steep and long slopes. This allows you to use the engine braking effect and to reduce the strain on the brake system. Otherwise, the brakes may overheat and fail. Only use the brakes to reduce speed or to stop. ■

Warning and control lamps

If lit up	Possible cause	Solution
 (red)	Fault in the automatic gearbox.	 Do not drive on! Seek professional advice. Failure to do so could result in considerable damage to the transmission → page 132.
 (yellow)	In the automatic gearbox the gears can engage incorrectly.	Switch the ignition on and off. When the control lamp does not light up, find the nearest specialised workshop and have the automatic gearbox checked.
	The automatic gearbox overheats temporarily.	Let the transmission cool with the gearbox lever in the position N . When the control lamp does not light up, find the nearest specialised workshop and have the automatic gearbox checked.

If lit up	Possible cause	Solution
	Place the automatic gearbox lever in the position N and do not press the brake pedal.	Press the brake pedal to select a gear range.
	Together with the yellow control lamp for the temperature of the transmission  : the automatic gearbox overheats.	Press brake pedal and let the transmission cool. Avoid pressing the accelerator. When the control lamp does not light up, find the nearest specialised workshop and have the automatic gearbox checked.
	Together with the turn signal display in the instrument panel display: the automatic gearbox lever is not in the position N , indication to start the engine.	Move the gearbox lever to the position N and start the engine. ▶

If flashing	Possible cause	Solution
	An automatic gearbox in the vehicle does not guarantee that the vehicle will not roll away.	Apply the handbrake.
N	In the instrument panel display, in addition to the control lamp requesting the brake pedal to be pressed  : Indication to start the engine.	Move the gearbox lever to the position N and start the engine.
	On the instrument panel display: Whilst driving in a forward direction, try to move the automatic gearbox lever to the position R .	Stop the vehicle and move the gearbox lever to the position N in order to subsequently change to the position R .
	On the instrument panel display: The automatic gearbox lever was placed in the position R or D , but the brake pedal was not pressed.	Press the brake pedal, move the gearbox lever to the position N , and subsequently to the required position R or D .

When switching on the ignition some warning and control lamps light up for a short time to check the operations. They will switch off after a few seconds. ■

Pedals

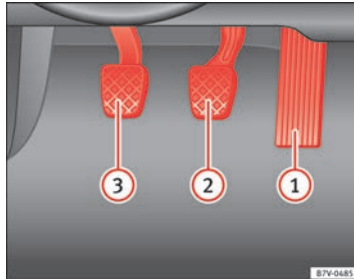


Fig. 84 Pedals in vehicles with a manual gearbox: ① accelerator; ② brake; ③ clutch

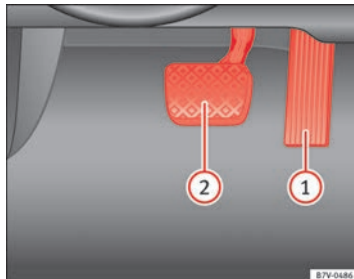


Fig. 85 Pedals in vehicles with an automatic gearbox: ① accelerator; ② brake

Do not allow floor mats or other objects to obstruct the free passage of the pedals.

Floor mats should leave the pedal area vacant and unobstructed and be correctly secured in the footwell zone.

In the event of failure of a brake circuit, the brake pedal must be pressed harder than normal to brake the vehicle.

WARNING

Objects falling into the driver's footwell could prevent use of the pedals. This could lead the driver to lose control of the vehicle, increasing the risk of a serious accident.

- Make sure the pedals can be used at all times, with no objects rolling underneath them.
- Always secure the mat in the footwell.
- Never place other mats or rugs on top of the original mat supplied by the factory.
- Ensure that no objects can fall into the driver's footwell while the vehicle is in motion.

CAUTION

The pedals must always have free and unobstructed passage to the floor. For example, in case of a fault in the brake circuit, the brake pedal will need to be pressed further to stop the vehicle. To press the brake pedal down further will require more force than usual.

Manual gearbox: Engaging gears



Fig. 86 Gear shift pattern of a 5-speed manual gearbox

The position of each of the gears is shown on the gear stick → Fig. 86.

- Keep the clutch pedal pushed all the way down.
- Move the gearbox lever to the required position → ⚠.
- Release the clutch pedal to engage clutch.

In some countries, it is necessary to press the clutch pedal to the floor to start the engine.

Selecting reverse gear

- Engage reverse gear only when the vehicle is stopped.
- Keep the clutch pedal pushed all the way down → ⚠.
- Move the gear lever into the neutral position.
- Move the gear stick to the right and then backwards to reverse gear (R).
- Release the clutch pedal to engage clutch.

Shifting down a gear

Shifting down a gear while driving must be carried out gear by gear, i.e. to the gear immediately preceding the current gear and at an engine speed that is not excessive → ⚠. At high speeds, or high engine speeds, skipping one or various gears when shifting down a gear can cause damage to the clutch and the gearbox, even if the clutch is not engaged during the process → ⚠.



WARNING

When the engine is running, the vehicle will start to move as soon as a gear is engaged and the clutch released.

- Never engage the reverse gear when a vehicle is moving forward.



WARNING

As a consequence of shifting down a gear incorrectly, you may lose control of the vehicle and cause an accident with serious consequences.



CAUTION

If, at high speeds or high engine speeds the gear lever is shifted down to a gear that is too low, serious damage can be caused to the clutch and gearbox. This also applies if you press the clutch pedal and it does not engage.



CAUTION

To prevent damage and avoid premature wear, please observe the following:

- While driving, do not leave your hand resting on the gear stick. The pressure applied by your hand is transmitted to the gearbox selector forks.
- Always ensure that the vehicle is completely stopped before engaging the reverse gear. ▶

- When changing gear, always make sure the clutch pedal is pushed right to the floor.
- Never hold the vehicle “on the clutch” on hills.

Automatic gearbox: engaging a gear



Fig. 87 Automatic gearbox selector lever

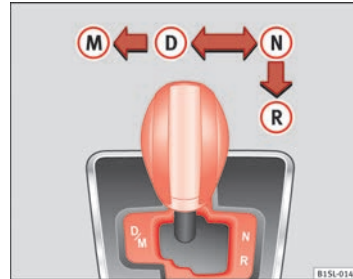


Fig. 88 Automatic gearbox diagram of gears

To move the gear selector lever from the position **N** to **D** or to **R**, first press and hold the brake pedal.

In the instrument panel display, with the ignition switched on, the selected gear range or the gear engaged in the gearbox is shown.

Selector lever positions	Denomination	Meaning ⇒ ⚠
R	Reverse gear	Reverse gear is selected. Engage only when the vehicle is <i>stopped</i> .
N	Neutral	The gear box is in neutral. No movement is transmitted to the wheels and the engine does not act as a brake.

Selector lever positions	Denomination	Meaning ⇒ ⚠
D	Standard driving position	The gears are changed (up and down) automatically. The gear shifts are determined by the engine load, your individual driving style and the speed of the vehicle.
M	Tiptronic driving position (manual shift programme)	All gears can be changed (up and down) manually ⇒ page 130. This is possible as long as the system is not changing gear automatically due to a traffic situation.

⚠ WARNING

Placing the selector lever in an incorrect position may cause loss of control of the vehicle and a serious accident.

- Do not press the accelerator when engaging a range of gears.
- With the engine running and a gear range selected, the vehicle will move off when the brake pedal is released.
- Never engage reverse gear while driving.
- Unintentional movements of the vehicle could cause serious injury.
- As a driver, you should never leave your vehicle if the engine is running and a gear range is engaged. If you have to leave your vehicle while the engine is running, you must always apply the handbrake and put the selector lever in position **N**.
- Never engage the **R** gear range when the vehicle is moving.
- Never leave the vehicle without applying the handbrake. With the engine running the vehicle moves downhill regardless of the gear range selected.

ⓘ Note

If, while driving, the selector lever is accidentally placed in position **N**, lift your foot off the accelerator. Wait until the engine is running at idle speed before selecting a new gear range.

Engaging gear with Tiptronic

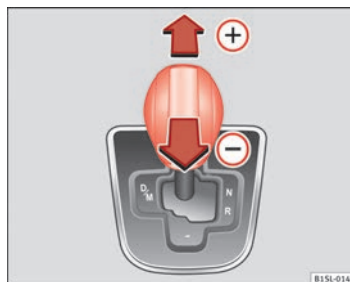








Fig. 89 Lever in the Tiptronic position

With Tiptronic, the gears can be changed up or down manually with the automatic gearbox. When you change to the Tiptronic programme, the vehicle remains in the currently selected gear. This is possible as long as the system is not changing gear automatically due to a traffic situation.

Using Tiptronic

- Place the lever in the position **D** to the left on the Tiptronic shift gate **M** ⇒  in Automatic gearbox: engaging a gear on page 130.
- Press the lever forwards  or backwards  to move up or down a gear ⇒ Fig. 89.
- Place the lever back to the position **M** to the left on the Tiptronic shift gate, to leave Tiptronic mode ⇒  in Automatic gearbox: engaging a gear on page 130.

With the lever in the position **D**, and pressing forwards  or backwards  the Tiptronic programme can be selected **M**.



CAUTION


- When accelerating, the gearbox automatically shifts up into the next gear shortly before the maximum engine speed is reached.
- When reducing speed manually, the gear box only shifts gear when the engine can no longer exceed the maximum engine speed. ■

Driving with an automatic gearbox

The gearbox changes up or down gears automatically as the vehicle moves.


Driving down hills

The steeper the gradient, the lower the gear you will need to select. The lowest gears increase the engine braking work. Never go down hills with the selector lever in neutral **N**.

- You should reduce speed accordingly.
- Place the lever in the position **D** to the left on the Tiptronic shift gate **M** ⇒ page 130.
- Gently pull the selector lever back  to change down a gear.


Starting when going up a slope

The steeper the gradient, the lower the gear you will need.

When stopping on a slope with a gear range engaged, the vehicle must be prevented from rolling backwards by always pressing the brake pedal or pulling the handbrake lever up. When starting, release the brake pedal or the handbrake ⇒ .

Kickdown

The kickdown system provides maximum acceleration when the gear selector lever is in the position **D**, or in the Tiptronic position **M**.

When the accelerator pedal is pressed right down, the automatic gearbox will shift down to a lower gear, depending on road speed and engine speed. This takes advantage of the maximum acceleration of the vehicle ⇒ .

When the accelerator is pressed to the floor, the automatic gearbox shifts to the next gear only after the engine reaches the specified maximum engine speed.



WARNING

Rapid acceleration can cause loss of traction and skidding, especially on slippery ground. This could cause loss of control of the vehicle resulting in an accident and serious injury.

- Always adapt your driving style to suit the flow of traffic.
- Only use the kickdown function or rapid acceleration if visibility, weather, road and traffic conditions so permit.
- Never put other road users in danger by accelerating or with your driving style.



CAUTION

If you stop on a hill with a gear range engaged, do not try to prevent the vehicle from rolling back by pressing on the accelerator. Otherwise, the automatic gearbox may overheat causing damage. ■

Automatic gearbox malfunction



Back-up programme

When automatic gearbox warning and control lamps light up on the instrument panel, there may be a system malfunction ⇒ page 124. In the event of some faults the automatic gearbox functions using a backup programme. When the backup programme is activated, it is possible to drive the vehicle, however, at low speeds and within a selected range of gears.

With the manual gearbox, in some cases **it is not possible to drive with all the gears.**

In all cases the automatic gearbox must be checked at a specialised workshop.

Automatic gearbox overheating

The automatic gearbox can overheat with a prolonged start up, or when stopping and starting continuously. This overheating is displayed with a warning lamp  in the instrument panel. Additionally, an audible warning can be heard. Stop and let the gearbox cool ⇒ .

The vehicle moves forward or back despite having selected a gear range

When the vehicle does not move in the required direction, the system may not have the gear range correctly engaged. Press the brake pedal and engage the gear range again. If the vehicle still does not move in the required direction, there is a system malfunction. Seek specialist assistance and have the system checked.






CAUTION

- When the gearbox is displayed as overheating for the first time, the vehicle must be parked safely or must be driven at a speed of more than 20 km/h (12 mph).
- When the warning lamp lights up and the audible warning is sounded, the vehicle must be parked safely and the engine switched off. Let the gearbox cool down.
- To prevent damage to the gearbox, driving must only be continued when the warning lamps are no longer lit up. While the gearbox is overheated, starting up and driving at walking speed should be avoided. ■

Recommended gear display

In some vehicles, the recommended gear for reducing fuel consumption is displayed on the instrument panel display:

Display	Meaning
	Optimum gear.
	Recommendation to change up a gear.
	Recommendation to change down a gear.



WARNING

The recommended gear display is intended as a guideline only; it should never replace the driver's attention to driving carefully.

- Responsibility for selecting the correct gear for each situation continues to lie with the driver, for example when overtaking or climbing a hill. ▶

**For the sake of the environment**

Selecting the most appropriate gear for the situation will help you to save fuel.

**Note**

The recommended gear display is switched off when the clutch pedal is pressed.

**Note**

On the display of the Portable Navigation System (supplied by SEAT) ⇒ page 222 the recommended gear can also be seen. ■

Braking, stopping and parking

Introduction

The **assisted braking systems** are the electronic distribution of the brake force (EBV), the anti-lock brake system (ABS), the brake assist system (BAS), the electronic differential lock (EDL), the traction control (TC), the traction control system (ASR) and the electronic stability control (ESC*).

Additional information and warnings:

- Wheels and tyres ⇒ page 210
- Accessories, parts replacement, repairs and modifications ⇒ page 222



WARNING

Driving with worn brake pads or a faulty brake system may lead to serious accident.

- If you believe the brake pads to be worn or the brake system to be faulty, immediately refer to a specialised workshop to check the brake pads and replace the worn brake pads.



WARNING

Careless parking can cause serious injury.

- Never remove the key from the ignition if the vehicle is in motion. The steering lock may engage and locked the steering wheel making the vehicle impossible to control.
- Always park your vehicle so that no part of the exhaust system can come in contact with flammable materials (such as wood, leaves, spilled fuel, dried grass, etc).



WARNING (Continued)

- Always apply the handbrake when you leave your vehicle and when you park.
- Never leave children or disabled people alone in the vehicle. They could release the electronic parking brake, activate the selector lever or gear stick and start the vehicle moving. This could result in serious accident.
- Always take all the keys with you whenever you leave the vehicle. The engine could accidentally be started and electrical equipment such as the windows could accidentally be operated resulting in serious injury.
- Never leave children or disabled people alone in the vehicle. They could be trapped in the vehicle in an emergency and will not be able to get themselves to safety. For example, depending on the time of the year, temperatures inside a locked and closed vehicle can be extremely high or extremely low resulting in serious injuries and illness or even death, particularly for young children.



CAUTION

- Special care should be taken when parking in areas with high kerbs or fixed barriers. Objects protruding from the ground may damage the bumper or other parts of the vehicle during manoeuvres. To avoid damage, stop before the wheels touched the barrier or kerb.
- Special attention is required when driving through entrances, over ramps, kerbs or other objects. The vehicle underbody, bumpers, mudguards and running gear, and the engine and exhaust system could be damaged as you drive over these objects.

Warning and control lamps

lights up	Possible cause ⇒ ⚠	Solution
	Handbrake applied.	⇒ page 136.
	Fault in the brake system.	Do not drive on! Seek professional advice ⇒ page 138.
	Brake fluid level inadequate.	Do not drive on! Check brake fluid level ⇒ page 142.
	Together with the ABS control lamp : ABS and EBV do not function.	Do not drive on! Seek professional advice ⇒ page 138.
	ESC* disconnected by system.	Switching the ignition on and off. If necessary, drive for a short distance.
	Fault in ESC*.	Contact a Specialised workshop.
	Together with the ABS control lamp : Fault in ABS.	Contact a Specialised workshop. The vehicle can be braked without ABS.
	The battery has been reconnected.	⇒ page 193.
	Traction Control faulty or switched off by the system.	Contact a Specialised workshop.
	Together with the ESC* control lamp : Fault in ABS.	Contact a Specialised workshop. The vehicle can be braked without ABS.
	Together with the warning lamp : ABS and EBV do not function.	Do not drive on! Seek professional advice ⇒ page 138.

flash- es	Possible cause	Solution
	ESC* or ASR regulating.	Take your foot off the accelerator. Adjust your driving style to the road conditions.
	Traction Control regulator operating.	Take your foot off the accelerator. Adjust your driving style to the road conditions.

Several warning and control lamps light up for a few seconds when the ignition is switched on while a test of the function is being carried out. They will switch off after a few seconds.

WARNING

If the warning lamps are ignored, the vehicle may stall in traffic, or may cause accidents and severe injuries.

- Never ignore the warning lamps.
- Stop the vehicle safely as soon as possible.


WARNING

Driving with brakes in bad condition could result in a serious accident.

- If the brake warning lamp does not go out, or if it lights up when driving, the brake fluid level in the reservoir is too low or there is a fault in the brake system. Obtain professional assistance immediately
⇒ page 141, Brake fluid.
- If the brake warning lamp lights up together with the ABS warning lamp , the regulation function of the ABS could be malfunctioning. As a result, the rear wheels can lock relatively easily when braking. If the rear wheels lock this could result in loss of vehicle control! If possible, reduce

⚠ WARNING (Continued)

your speed and drive carefully to a Specialised workshop close by to check the brake system. During the following journey, avoid sudden braking and manoeuvres.

- If the ABS warning lamp  does not go out or if it lights while driving, the ABS is malfunctioning. The vehicle can only be stopped using normal braking without ABS. The protection provided by the ABS is not available. Visit a specialised workshop as soon as possible.


**CAUTION**

Failure to heed the warning lamps when they appear may result in faults in the vehicle.

Handbrake

Fig. 90 Between the front seats: Handbrake

Using the handbrake

- Pull firmly in an upwards direction on the handbrake lever while pressing the button.
- The handbrake is applied when the control lamp  lights up on the instrument panel → page 135 when the ignition is switched on.

Releasing the handbrake

- Pull gently in an upwards direction on the handbrake lever and press the lock button → Fig. 90 (arrow).
- Move the handbrake lever downwards keeping the lock button pressed.

**WARNING**

The incorrect use of the handbrake may result in a serious accident.

- Never use the handbrake to brake the vehicle except in an emergency. The braking distance is considerably longer, because braking is only applied to the rear wheels. Always use the foot brake.
- Never drive with the handbrake gently applied. This can overheat the brake, affecting the brakes system. This also causes premature wear on the rear brake pads.
- Never accelerate from the engine compartment with the engine running and a gear engaged. The vehicle could move, even if the handbrake is applied.

**Note**

If the vehicle moves at a speed superior to 6 km/h (4 mph) with the handbrake applied, an audible warning is sounded.

Parking

When parking your vehicle, all legal requirements should be observed.

To park the vehicle

Complete operations only in the sequence given.

- Park the vehicle on a suitable surface ⇒ ⚠.
- Press and hold the brake pedal until the vehicle comes to a standstill.
- Apply the handbrake firmly ⇒ page 136.
- For an automatic gearbox, move the selector lever to position **P**.
- Switch off the engine and release the brake pedal.
- Remove the key from the ignition.
- If necessary, turn the steering wheel slightly to lock the steering.
- With a manual gearbox, engage the 1st gear on flat ground and slopes, or even the reverse gear on hills, and release the clutch pedal.
- Ensure that all passengers leave the vehicle, especially children.
- When leaving the vehicle, take all keys with you.
- Locking the vehicle.

Additional information for steep slopes and hills

Before switching off the engine, rotate the steering wheel so that if the vehicle should move then it will be held by the kerb.

- On slopes, turn the front wheels so that they are against the edge of the kerb.
- Uphill, turn the wheels towards the centre of the road.

! WARNING

The components of the exhaust system reach very high temperatures. This could cause a fire and considerable damage.

- Always park your vehicle so that no part of the exhaust system can come in contact with flammable materials (such as wood, leaves, spilled fuel, dried grass, etc).

! CAUTION

- Special care should be taken when parking in areas with high kerbs or fixed barriers. Objects protruding from the ground may damage the bumper or other parts of the vehicle during manoeuvres. To avoid damage, stop before the wheels touched the barrier or kerb.
- Special attention is required when driving through entrances, over ramps, kerbs or other objects. The vehicle underbody, bumpers, mudguards and running gear, and the engine and exhaust system could be damaged as you drive over these objects. ■

Information about the brakes

For the first 200 to 300 km (120 to 190 mph), the **new brake pads** have not yet reached their maximum braking capacity, and need to be “run in” first ⇒ ⚠. The slightly reduced braking effect can be compensated for by increasing pressure on the brake pedal. **While running in, the full braking distance or emergency braking distance is larger** than when the brake pads have been run in. While running in, avoid full power braking or situations requiring braking performance. For example, in heavy traffic.


The **rate of wear of the brake pads** depends to a great extent on the conditions in which the vehicle is used and the way the vehicle is driven. If the vehicle is used frequently in city traffic or for short trips or driven sport style, visit a Specialised workshop regularly more frequently than advised in the Maintenance Programme to have the brake pads checked.

If you drive with **wet brakes**, for example, after crossing areas of water, in heavy rainfall or even after washing the vehicle, the effect of the brakes is lessened as the brake discs are wet or even frozen (in winter). At higher speed, “dry” the brakes as quickly as possible by braking gently several times. Only do this without endangering vehicles behind you or any other road users ⇒ ⚠. ▶

A **layer of salt on the discs and brake pads** will reduce brake efficiency and increase braking distance. If you drive for a prolonged period on salted roads without braking then brake carefully several times to eliminate the layer of salt on the brakes ⇒ ⚠.

If the vehicle remains parked for considerable lengths of time, is used little, or if the brakes are not used, there may be **corrosion** on the brake discs and a build-up of **dirt** on the brake pads. If the brakes are not used frequently, or if rust has formed on the discs, SEAT recommends cleaning the pads and discs by braking firmly a few times at a moderately high speed. Only do this without endangering vehicles behind you or any other road users ⇒ ⚠.

Faults in the brake system

During braking, if you notice that the vehicle does not react as usual (that the braking distance has increased suddenly) it may be possible that there is a fault in the braking system. This is indicated by the warning lamp . Take the vehicle to a Specialised workshop immediately and have the fault repaired. Drive at a moderate speed and be prepared to use more pressure on the brake pedal, and allow for longer braking distances.

Brake servo

The brake servo only operates when the engine is running and the pressure applied by the driver on the brake pedal increases.

If the brake servo does not operate or the vehicle must be towed, then the brake pedal will have to be pressed with more force given that the braking distance will be increased when the brake servo does not operate ⇒ ⚠.

WARNING

New brake pads do not brake to full efficiency.

- For the first 320 km (200 miles), new brake pads have not yet reached their maximum braking capacity, and need to be “run in” first. For this, to compensate for reduced braking efficiency the brake pedal will have to be pressed with more force.

WARNING (Continued)

- To avoid losing control of the vehicle and causing serious accidents, always take great care when driving with new brake pads.
- When running in new brake pads, always respect the safety distances between you and other vehicles and do not cause situations requiring extreme braking performance.

WARNING

When brakes overheat, braking is less efficient and braking distances increase.

- When driving on slopes, brakes can be overloaded and overheat quickly.
- Reduce speed or reduce the gear when faced with steep and long slopes. This allows you to use the engine braking effect and to reduce the strain on the brake system.
- Non-standard or damaged front spoilers could restrict the airflow to the brakes and cause them to overheat.

WARNING

Wet, frozen or salt-covered brakes take time to brake and this increases braking distances.

- Test the brakes carefully.
- Dry the brakes, free them of ice and salt by braking gently several times, when visibility, weather, and road and traffic conditions permit. ▶

 **WARNING**

Driving without the brake servo may significantly increase the braking distance and result in a severe accident.

- Never allow the vehicle to move forwards when the engine is switched off.
- If the brake servo does not operate or the vehicle must be towed, then the brake pedal will have to be pressed with more force given that the braking distance will be increased when the brake servo does not operate.

 **CAUTION**

- Never make the brakes “slip” by pressing the pedal gently, if it is not really necessary to brake. Continuously pressing on the brake pedal will heat the brakes. This could significantly reduce braking power, increase braking distance or even result in the total failure of the brake system.
- Reduce speed or reduce the gear when faced with steep and long slopes. This allows you to use the engine braking effect and to reduce the strain on the brake system. Otherwise, the brakes may overheat and fail. Only use the brakes to reduce speed or to stop.

 **Note**

Make use, when having the front brake pads checked, and have the rear pads checked also. The thickness of the brake pads should be checked visually and regularly, by looking through the openings in the wheel rims or from underneath the vehicle. If necessary, remove the wheels to check them thoroughly. SEAT recommends visiting a Technical Service. ■

Assisted braking systems

The assisted braking systems ESC*, ABS, EBV, BAS, ASR, TC and EDL only operate when the ignition is switched on. They contribute significantly to increasing active safety.

Electronic Stability Control (ESC)*

ESC* reduces the risk of skidding and increases the vehicle stability by braking individual wheels under specific driving conditions. ESC* detects critical handling situations, such as understeer, oversteer and wheelspin on the driven wheels. The system stabilises the vehicle by braking individual wheels or by reducing the engine torque.

The ESC* has limits. It is important to realise that the ESC* is also subject to the laws of physics. ESC* will not be able to deal with all situations with which drivers may be faced. For example, if the road surface changes suddenly then ESC* will not be useful in all cases. If the vehicle suddenly enters a section covered by water, mud or snow then ESC* will not provide assistance in the same way as on dry ground. If the vehicle loses its grip on the ground and moves on a film of water (“aquaplaning”), the ESC* will not be able to assist the driver to control the vehicle due to the loss of adherence with the road surface preventing braking and steering. If the vehicle is driven through series of bends at high speed, the ESC* will not always be as effective: the vehicle reaction to aggressive driving is not the same as at reduced speeds.

Adjust your speed and driving style to suit visibility, and weather, road and traffic conditions. ESC* cannot push the limits of the laws of physics; improve the transmission available or maintain the vehicle on the road if a lack of driver attention creates an inevitable situation. Otherwise, ESC* assists in maintaining vehicle control in extreme situations and uses the movements of the steering made by the driver to maintain the vehicle moving in the desired direction. If the vehicle is driven at such a speed that it will leave the road before ESC* can intervene then the system cannot provide assistance. ▶

Vehicle diagram

Prior to a journey...

While driving

Care, cleaning and maintenance

If and when

Technical Data

The ABS, BAS, ASR and EDL systems are incorporated into the ESC*. The ESC* is always on¹⁾.

Anti-lock brake system (ABS)

ABS can prevent the wheels from locking during braking until just before the vehicle stops thus helping the driver to steer the vehicle and maintain control. This means that, even during full braking, the risk of skidding is reduced:

- Press and hold the brake pedal fully. Do not remove your foot from the brake pedal or reduce braking force!
- Do not “pump” the brake pedal, or reduce braking force!
- Maintain vehicle direction when braking fully with the brake pedal.
- When the brake pedal is released or when the brake force is reduced, ABS is turned off.

ABS control can be observed by **vibration of the brake pedal** and noise. You should never expect the ABS to reduce the braking distance under *any* circumstances. Braking distances will increase when driving on gravel, recent snow or on icy and slippery ground.

Brake assist system (BAS)

The brake assist system may reduce the required braking distance. The brake assist system boosts the braking force if you press the brake pedal quickly in an emergency. As a result, the braking pressure increases rapidly, the braking force is multiplied and the braking distance is reduced. This enables the ABS to be activated more quickly and efficiently.

!Do **not** lift your foot off the brake pedal! When the brake pedal is released or when the brake force is reduced, braking assist automatically turns off the brake servo.

Traction control system (ASR) or Traction Control (TC)

In the event of wheelspin, the traction control system ASR or TC reduces the engine torque to match the amount of grip available. The ASR or TC makes some situations easier, for example, when starting, accelerating or going uphill, even in unfavourable road conditions.

Electronic differential lock system (EDL)

EDL is available when driving in straight lines under normal conditions. When the EDL detects wheelspin, it brakes the spinning wheel and directs the power to the other driven wheel. To prevent the disc brake of the braked wheel from overheating, the EDL cuts out automatically if subjected to excessive loads. The EDL will switch on again automatically when the brake has cooled down.



WARNING

Driving at high speed on icy, slippery wet ground can result in loss of vehicle control and serious injury to the driver and passengers.

- **Adjust your speed and driving style to visibility, road, traffic and weather conditions. Even though the braking assist systems, ABS, BAS, EDL, ASR, TC and ESC*, provide more security, do not take unnecessary risks while driving.**
- **Braking assist systems can not overcome the laws of physics. Even with ESC* and other systems, slippery and wet roads will always be dangerous.**
- **Driving to quickly on wet ground can result in the wheels losing contact with the ground in an effect known as “aquaplaning”. Without adherence, it is impossible to brake, steer or control the vehicle.**
- **Braking assist systems cannot avoid accidents if, for example, the driver does not respect safety distances or drives to quickly in difficult conditions.**

¹⁾ According to version

⚠ WARNING (Continued)

- Even though braking assist systems are extremely effective and help control the vehicle in difficult situations, remember that the vehicle stability depends on tyre grip.
- When accelerating on a slippery surface, for example on ice and snow, press the accelerator carefully. The wheels can still slip even with braking assist systems resulting in loss of vehicle control.

⚠ WARNING

The effectiveness of the ESC* can be considerably reduced if other components and systems affecting driving dynamics are not maintained or are not functioning correctly. This includes, among others, brakes, tyres and other systems already mentioned.

- Remember that changing and fitting other components to the vehicle can affect operation of the ABS, BAS, ASR TC, EDL and ESC*.
- Changes to the vehicle suspension or using unapproved wheel/tyre combinations can affect operation of the ABS, BAS, ASR, TC, EDL and ESC* and their effectiveness.
- Likewise, the effectiveness of ESC* depends on the use of suitable tyres ⇒ page 210.

i Note

To ensure that the ESC*, ASR and TC work properly, all four wheels must be fitted with identical tyres. Any differences in the rolling radius of the tyres can cause the system to reduce engine power when this is not desired.

i Note

If a malfunction should occur in the ABS, the ESC*, ASR, TC and EDL will also be affected.

i Note

Noises may be heard while any of the above systems are operating. ■


Brake fluid

Fig. 91 In the engine compartment: brake fluid reservoir, lid

In the course of time, the brake fluid absorbs water from the ambient air. If there is too much water contained in the brake fluid, the brake system could be damaged. In addition, the boiling point of the brake fluid is significantly lowered. When the brake fluid contains too much water and the brakes are subject to considerable forces, bubbles of water vapour can form in the system. These bubbles of water vapour can significantly reduce braking power, notably increasing braking distance, and could even result in the total failure of the brake system. Ensuring that the brake system is always functioning correctly is essential for your own safety and the safety of other road users ⇒ ⚠.

Brake fluid specifications


SEAT have developed a special brake fluid optimised for the brake systems of their vehicles. To ensure the optimum working of the brake system, SEAT ►

recommends the use of brake fluid in accordance with the **VW 501 14 standard**. If this brake fluid is not available or another brake fluid is used for different reasons, use a brake fluid that complies with the United States standard FMVSS 116 DOT 4 or the German standard DIN ISO 4925 CLASS 4 ⇒ .

Brake fluids conforming to the standard VW 501 14, fulfil the American requirements of the FMVSS 116 DOT 4 standard and the German DIN ISO 4925 CLASS 4 standard. However, fluids that comply with the American FMVSS 116 DOT 4 standard or the German DIN ISO 4925 CLASS 4 standard do not necessarily comply with the VW 501 14 standard. Always check the information on the brake fluid container and ensure that you are using suitable brake fluid.

A suitable brake fluid can be obtained from SEAT dealerships.

Brake fluid level

The level of the brake fluid should always be between the MIN and MAX marks, or above the MIN mark ⇒ .

It is not always possible to check the level of the brake fluid, as in some models the engine components make it difficult to see the brake fluid reservoir. If you cannot read the exact brake fluid level, consult a specialist.

The brake fluid level drops slightly when the vehicle is being used due to wear of the brake pads and the automatic readjustment of the brake.

Changing the brake fluid

The brake fluid should be changed in accordance with the instructions given in the Maintenance Programme. Have the brake fluid changed by a specialised workshop. SEAT recommends visiting a Technical Service. This means that only brake fluid complying with the required specifications will be used.



WARNING

If the brake fluid level is low or unsuitable/old brake fluid is used, the brake system may fail or braking power will be reduced.

- Check the brake system and the brake fluid level regularly!
- The brake fluid should be changed regularly in accordance with the instructions given in the Maintenance Programme.
- When the brake fluid is used and brakes are subjected to extreme braking forces, bubbles of vapour form in the brake system. These bubbles of water vapour can significantly reduce braking power, notably increasing braking distance, and could even result in the total failure of the brake system.
- Always ensure that you use suitable brake fluid. Only used brake fluid that conforms to the VW 501 14 standard, FMVSS 116 DOT 4 standard or even the DIN ISO 4925 CLASS 4 standard. Other types of brake fluid could affect brake operation and reduce braking power. Do not use a brake fluid if the container does not specify compliance with the VW 501 14, FMVSS 116 DOT 4 or DIN ISO 4925 CLASS 4 standards.
- The replacement brake fluid must be new.



WARNING

Brake fluid is poisonous.

- To reduce the risk of poisoning, do not keep brake fluid in drinks bottles/containers or similar. Other people could drink from these recipients even if the contents are clearly marked.
- Always keep brake fluid in the original container; keep it correctly sealed and out of reach of children.



CAUTION

Brake fluid could damage the paintwork. Wipe off any brake fluid from the paintwork immediately. ▶

**For the sake of the environment**

Brake fluid is an environmental pollutant. Collect any spilt service fluids and allow a professional to dispose of them. ■

Vehicle diagram

Prior to a journey...

While driving

Care, cleaning and maintenance

If and when

Technical Data

Ecological driving

Introduction

Fuel consumption, environmental impact and engine, brake and tyre wear depend largely on 3 factors:

- Personal driving style.
- Conditions of use (weather, road surface).
- Technical requirements.

Savings of up to 25% in fuel consumption are possible with an appropriate driving style and the adoption of certain simple tips.



WARNING

Always adapt your speed and the distance to the vehicles ahead in line with visibility, weather conditions, the condition of the road and the traffic situation.

Economic driving style

Changing gear early

General instructions: The highest gear is always the most economical gear. As a guideline, for the majority of vehicles: At a speed of 30 km/h (19 mph), drive in third gear, at 40 km/h (25 mph) in fourth gear and at 50 km/h (30 mph) in fifth gear.

In addition, “skipping” gears when shifting up helps to save fuel, weather and traffic conditions permitting.

Do not wait until the last moment before changing gear. Only use first gear when you move off and change to second gear quickly. Avoid the kickdown function in vehicles with automatic gearbox.

Vehicles with a gear display help to achieve an economical driving style as the display indicates the best moment to change gear.

Let the vehicle roll

If you take your foot off the accelerator, the fuel supply is stopped and consumption is reduced.

Allow the vehicle to roll without accelerating, for example when approaching a red traffic light. However, if the vehicle is rolling too slowly or the distance is too long, the clutch pedal should be pressed to declutch. The engine will then operate at idle speed.

If the vehicle is going to be at a standstill for a period of time, switch off the engine; for example, while waiting at a level crossing.

Think ahead and “flow” with the traffic

Frequent acceleration and braking considerably increase fuel consumption. If you think ahead as you drive and keep a safe distance from the vehicle in front, it is possible to slow down by simply lifting your foot off the accelerator. This eliminates the need for constant braking and acceleration.

Calm and steady driving

Constancy is more important than speed: The more you drive at a constant speed, the lower the fuel consumption.

When driving on the motorway, it is more efficient to drive at a constant and more moderate speed than to be continuously accelerating and braking. As a general rule, you will reach your destination just as quickly when you drive at a constant speed.

The cruise control function helps you to achieve a constant style of driving. ▶

Moderate use of additional electrical appliances

It is important to travel in comfort, but convenience systems should be used in an ecological manner.

Some equipment, when connected, increase fuel consumption considerably, for example:

- Air conditioning cooling system: If the air conditioning system is required to cool to significantly lower temperatures than the true outside temperature, it will require a large quantity of energy from the engine. Therefore, we recommend that the selected temperature for the vehicle is not too different to the outside temperature. It is a good idea to open all the windows of the vehicle before starting your journey, and to drive a short distance with all the windows open to allow the vehicle to cool down slightly. Only then should you close all the windows and switch on the air conditioning system. Keep windows closed when travelling at high speeds. Driving with the windows open increases fuel consumption.
- Switch off the seat heating when the seats have warmed up.
- Switch off the heated rear window when it is not moist or covered in ice.

Other factors which increase fuel consumption (examples):

- Fault in engine management.
- Driving on hills.

Saving fuel while driving

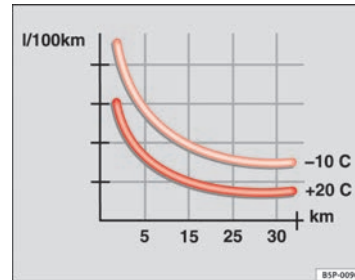


Fig. 92 Fuel consumption in litres per 100 km at 2 different outside temperatures

By adopting an economical driving style and anticipating the traffic situation ahead, you can easily reduce fuel consumption by 10-15%.

A vehicle uses most fuel when accelerating. By anticipating the traffic situation ahead, you will brake and therefore accelerate less. Wherever possible, let the vehicle roll slowly to a stop, for instance when you can see that the next traffic lights are red.

Avoid short journeys

Fuel consumption is much higher when the engine is cold, immediately after it has been started. It takes a few kilometres of driving for the engine to warm up and to normalise consumption.

The engine and catalytic converter need to reach their proper **working temperature** in order to minimise fuel consumption and emissions. The **ambient temperature** has a decisive influence.

Fig. 92 shows the difference in consumption for the same journey at +20 °C (+68 °F) and at -10 °C (+14 °F). ▶

Unnecessary short journeys should be avoided. Try to combine trips.

The vehicle uses more fuel in winter than in summer, even when other conditions are the same.

“Warming” the engine is not only forbidden in some countries, but in practice it is technically superfluous as it is a waste of fuel.

Adjusting tyre pressures.

Having the correct pressure in your tyres helps to reduce rolling resistance and, as a result reduces fuel consumption. Increasing the tyre pressure slightly (+ 0.2 bar / + 3 psi / + 200 kPa) can help to save fuel.

When you buy new tyres, make sure they are optimised for minimum rolling resistance.

Use low friction engine oil

The use of low viscosity totally synthetic oils, known as low friction engine oil, help to reduce fuel consumption. Low friction engine oils reduce the resistance caused by friction in the engine, they flow around the engine more quickly and efficiently, particularly in cold starts. The effect is particularly noticeable in vehicles frequently used for short journeys.

Always check the engine oil level and observe service intervals (engine oil change intervals).

When purchasing engine oil, always observe legal requirements and ensure that the oil is approved by SEAT.

Avoid carrying unnecessary loads

The lighter the vehicle, the more economical and ecological the driving style. For example, an additional weight of 100 kg will increase fuel consumption up to 0.3 ltr/100 km.

Remove any unnecessary objects or loads from the vehicle.

Remove optional equipment and unnecessary accessories

The more aerodynamic the vehicle, the lower the fuel consumption. Optional equipment and accessories (such as roof racks or bike carriers) reduce the aerodynamic benefits of the vehicle.

Therefore, we recommend you remove all optional and unnecessary equipment and racks, especially if you intend to drive at high speeds. ■

Steering

Introduction

The power steering* is not hydraulic but electromechanical. The advantage of this steering system is that it disposes of hydraulic tubes, hydraulic oil, the pump, filter and other components. The electromechanical system saves fuel. While a hydraulic system requires oil pressure to be maintained, electromechanical steering only requires energy when the steering wheel is turned.

With the electromechanical steering system, the power steering function automatically adjusts according to the vehicle speed, the steering torque and the wheel turning angle. The electromechanical steering only works when the engine is running.

Additional information and warnings:



- Start and stop the engine ⇒ page 119
- Vehicle battery ⇒ page 193
- Tow-starting and towing away ⇒ page 276




WARNING

If the power steering is not working then the steering wheel is much more difficult to turn and the vehicle more difficult to control.

- **The power steering only works when the engine is running.**
- **Never allow the vehicle to move when the engine is switched off.**
- **Never remove the key from the ignition if the vehicle is in motion. The steering may lock and it will not be possible to turn the steering wheel.**

Control and warning lamps

lights up	Possible cause	Solution
 (red)	Electromechanical steering faulty.	The steering system should be checked by a Specialised workshop as soon as possible.
 (yellow)	Electromechanical steering operation reduced.	The steering system should be checked by a Specialised workshop as soon as possible. If, after restarting the engine and driving for a short distance, the yellow warning light no longer comes on, it will not be necessary to take the vehicle to a specialised workshop.

flashes	Possible cause	Solution
 (red)	Fault in the steering column electronic lock.	 Do not drive on! Seek professional advice.
 (yellow)	Steering column deviation.	Gently turn the steering wheel to and fro. Remove the key from the ignition and then switch the ignition back on. If necessary, check the messages displayed on the instrument panel display.
	Steering wheel not unlocked or locked.	Do not drive on , if the steering column remains locked after the ignition has been switched on. You should obtain professional assistance. ▶

Several warning and control lamps light up for a few seconds when the ignition is switched on while a test of the function is being carried out. They will switch off after a few seconds.

**WARNING**

If the warning lamps are ignored, the vehicle may stall in traffic, or may cause accidents and severe injuries.

- Never ignore the warning lamps.
- Stop the vehicle safely as soon as possible.

**CAUTION**

Failure to heed the warning lamps when they appear may result in faults in the vehicle.

Electromechanical steering

With the electromechanical steering system, the power steering function automatically adjusts according to the vehicle speed, the steering torque and the wheel turning angle. The electromechanical steering only works when the engine is running.

You should remember that you will need considerably more power than normal to steer the vehicle if the power steering is not working correctly or not at all.

Information on the steering

To prevent theft, we recommend you lock the steering before leaving the vehicle.

Mechanical steering lock

Lock the steering column by removing the key from the ignition when the vehicle is stopped.

Please engage steering lock	Unlocking the steering
Parking the vehicle ⇒ page 134.	Insert the key in the ignition lock.
Remove the ignition key from the ignition.	Turn the steering wheel slightly to release the steering lock.
Turn the steering wheel slightly until you hear the steering lock.	Hold the steering wheel in this position and switch on the ignition.

Driver assistance systems

Parking distance warning system*

Introduction

The parking distance warning system assists the driver when parking. If the rear of the vehicle is approaching an obstacle, an intermittent audible warning is emitted. The shorter the distance, the shorter the intervals between tones. If the vehicle is too close to the obstacle, the audible warning becomes constant.

If you continue to approach an obstacle when the sound is continuous, this means the system can no longer measure the distance.

Sensors situated on the rear bumper transmit and receive ultrasound. Using the ultrasound signal (transmission, reflection from the obstacles and reception), this system continuously calculates the distance between the bumper and the obstacle.

Additional information and warnings:

- Exterior detail → page 6
- Accessories, parts replacement, repairs and modifications → page 222

WARNING

The parking distance warning system cannot replace the driver's assessment of the situation.

- The sensors have blind spots in which obstacles and people are not registered.
- Always observe the area around the vehicle, as the sensors do not always detect small children, animals or objects.

WARNING (Continued)

- The surface of certain objects and some clothing do not reflect the ultrasound signals from the parking distance system. The system cannot detect or incorrectly detects these objects and people wearing these types of clothes.
- External sound sources can affect the parking distance aid signals. In this case, under certain circumstances, people and objects will not be detected.

CAUTION

- The sensors may not always be able to detect objects such as trailer draw bars, thin rails, fences, posts, trees and open boots, etc. This could result in damage to your vehicle.
- Although the parking distance warning system detects and warns of the presence of an obstacle, the obstacle could disappear from the angle of measurement of the sensors if it is too high or low and the system would no longer indicate it. Therefore, it will not warn you of these objects. Ignoring the warnings of the parking distance warning system could cause considerable damage to the vehicle.
- The bumper sensors may become damaged or misaligned, for example, when parking.
- To ensure that the system works properly, the bumper sensors must be kept clean, free of ice and snow and uncovered.
- When cleaning the sensors with high-pressure or steam cleaning equipment, spray the sensors briefly at a distance of no less than 10 cm.
- Different sources of noise can produce errors in the parking distance warning system, i.e. parking distance warning systems from other vehicles, inductive loops or construction works machines.
- Retrofitting of components to the vehicle, such as a bicycle carrier, may interfere with the function of the parking distance warning system. ■

Vehicle diagram

Prior to a journey...

While driving

Care, cleaning and maintenance

If and when

Technical Data

Parking distance warning system

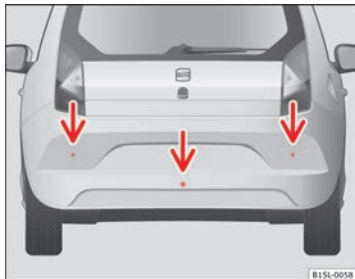


Fig. 93 Parking distance warning system sensors on the rear bumper

The 3 sensors of the parking distance warning system are situated on the rear bumper ⇒ Fig. 93.

Switching the parking distance warning system on and off

- **Switching on:** With the ignition switched on, select reverse gear. A short audible warning confirms that the parking distance warning system is switched on and functioning.
- **Switching off:** release reverse gear.

Things to note on the parking distance warning system

- The parking distance warning system sometimes registers water on the sensors as an obstacle.
- If the distance does not change, the warning signal will sound less loudly after a few seconds. If the continuous signal sounds, the volume will remain constant.

- When the vehicle moves away from the obstacle, the beeping sound automatically switches off. On approaching the obstacle again, the beeping sound will automatically switch back on.
- Your SEAT dealership can adjust the volume of the warning signals.



Note

A fault in the parking distance warning system is indicated through a brief audible warning that is constant for about 3 seconds when switching on for the first time. Check the parking distance warning system at a Specialised workshop as soon as possible. ■

Optical parking system* (OPS)

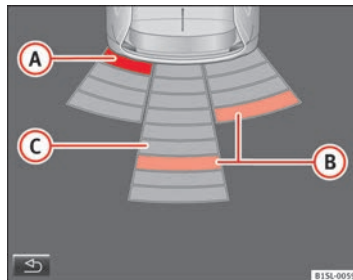



Fig. 94 On-screen OPS display: (A) an obstacle has been detected in the collision zone. (B) an obstacle has been detected in the segment. (C) zone recorded behind the vehicle

The optical parking system is an extension of the parking distance warning system ⇒ page 150.

On the screen of the SEAT Portable System (supplied by SEAT) the area behind the vehicle is shown registered by the sensors. Any obstacles are displayed in relation to the vehicle ⇒ ⚠.

Function	Necessary operations
Switching the display on:	Switching on the ⇒ page 150 parking distance warning system. The OPS switches on automatically.
Switching the display off manually:	Press the  button on the Portable Navigation System.
Switching the display off manually:	release reverse gear.

Zones explored

Behind the vehicle ⇒ Fig. 94 (C), the zone analysed reaches a distance of up to 150 cm and around 60 cm to the sides.

Screen display

The image displayed represents the supervised zones in several segments. As the vehicle moves closer to an obstacle, the segment moves closer to the vehicle displayed (A) or (B). When the penultimate segment is displayed, this means that the vehicle has reached the collision zone. **Stop the vehicle!**

Distance from the vehicle to the obstacle	Audible warning	Displayed in colour on the screen: colour of the segment if an obstacle is recognised
behind: approx. 31-150 cm	beeping sound	yellow
behind: approx. 0-30 cm	permanent sound	red

 WARNING
Do not be distracted from the traffic when looking at the screen.



Note

SEAT recommends practising using parking distance warning system in a traffic free zone or in a car park to familiarise yourself with the system and its operation.



Note

Representation of the registered area on the screen of the portable navigation system may take up to 5 seconds.



Note

Note the Instruction Manual provided for the device of the additional information relating to the Portable Navigation System (supplied by SEAT) ⇒ page 222.

Cruise control* (Cruise control system - CCS)

Introduction

The cruise control system (CCS) is able to individually maintain the set speed when driving forwards from approx. 20 km/h (12 mph).

The CCS only slows down by reducing the accelerator but not by braking ⇒ ⚠.

Additional information and warnings:

- Changing gear ⇒ page 124
- Accessories, parts replacement, repairs and modifications ⇒ page 222




WARNING

Use of the cruise control could cause accidents and severe injuries if it is not possible to drive at a constant speed maintaining the safety distance.

- Do not use the cruise control in heavy traffic, if the distance from the vehicle in front is insufficient, on steep roads, with several bends or in slippery circumstances (snow, ice, rain or loose gravel), or on flooded roads.
- Never use the CCS when driving off-road or on unpaved roads.
- Always adapt your speed and the distance to the vehicles ahead in line with visibility, weather conditions, the condition of the road and the traffic situation.
- To avoid unexpected operation of the cruise control system, turn it off every time you finish using it.
- It is dangerous to use a set speed which is too high for the prevailing road, traffic or weather conditions.
- When travelling down hills, the CCS cannot maintain a constant speed. The vehicle tends to accelerate under its own weight. Select a lower gear or use the brake pedal to slow the vehicle.

Control lamp

lights up	Possible cause
	This cruise control system maintains the set speed of the vehicle.

Several warning and control lamps light up for a few seconds when the ignition is switched on while a test of the function is being carried out. They will switch off after a few seconds.



WARNING

If the warning lamps are ignored, the vehicle may stall in traffic, or may cause accidents and severe injuries.

- Never ignore the warning lamps.



CAUTION

Failure to heed the warning lamps when they appear may result in faults in the vehicle.

Cruise control system operation

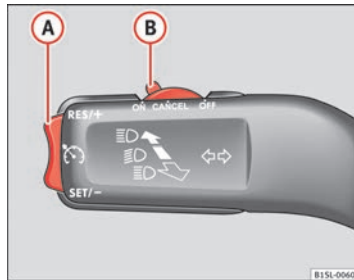


Fig. 95 Turn signal and main beam headlights lever on the left of the steering column: CCS buttons and controls

Function	Control position, control operations ⇒ Fig. 95	Action
Switching on the cruise control system.	Control (B) in the position ON .	The system is switched on. After switching on, no speeds are stored and no regulator has yet been placed.
Switching on the cruise control system.	Press button (A) in the area SET/- .	The current speed is stored and maintained.
Temporarily switching off the cruise control system.	Place control (B) in the position CANCEL . OR.: Press the brake or clutch pedal.	The cruise control system is switched off temporarily. The speed setting will remain stored.
Switching the speed setting back on.	Press button (A) in the area RES/+ .	The stored speed is reached again and maintained.

Function	Control position, control operations ⇒ Fig. 95	Action
Increasing the stored speed (during CCS setting).	Press the button (A) in the area RES/+ <i>briefly</i> to increase speed in shot measures of about. 1 km/h (1 mph) and store. Keep button (A) pressed in the area RES/+ for a <i>long time</i> to continually increase speed until releasing and storing.	The vehicle accelerates actively until it reaches the new stored speed.
Reducing the stored speed (during CCS setting).	Press the button (A) in the area SET/- <i>briefly</i> to reduce the stored speed in shot measures of about. 1 km/h (1 mph) and store. Keep button (A) pressed in the area SET/- for a <i>long time</i> to continually decrease stored speed until releasing and storing.	Reduce speed <i>without</i> braking, by interrupting the accelerator until reaching the new stored speed.
Switching off the cruise control system.	Control (B) in the position OFF .	The system is switched off. The stored speed is deleted.

Travelling down hills with the CCS

When travelling down hills the CCS cannot maintain a constant speed. Slow the vehicle down using the brake pedal and reduce gears if required.

Automatic off

The cruise control system (CCS) is switched off automatically or temporarily: ►

Vehicle diagram

Prior to a journey...

While driving

Care, cleaning and maintenance

If and when


Technical Data

- If the system detects a fault that could affect the working order of the CCS.
- If you increase the stored speed by pressing the accelerator pedal for a certain time.
- If the brake or clutch pedal is depressed.
- If the gear is changed with the manual gearbox.
- If the airbag is triggered. ■

Safety Assist* (City Safety Assist function)

Introduction

The City Safety Assist function covers driving situations at a distance of about 10 metres in front of the vehicle, in a speed range of approximately 5-30 km/h (3-19 mph).

When the system detects a possible collision with a vehicle in front, the vehicle prepares for a possible emergency braking ⇒ .

If the driver does not react to an imminent collision, the system can automatically brake the vehicle in order to reduce speed faced with a possible collision. The system can help to reduce the consequences of an accident.

If the City Safety Assist function determines that the driver braked insufficiently faced with an imminent collision, the system can increase the brake force in order to reduce speed. The system can help to reduce the consequences of an accident.

Additional information and warnings:

- Exterior detail ⇒ page 6
- Centre console, lower section ⇒ page 12
- Instrument panel ⇒ page 15
- Accessories, parts replacement, repairs and modifications ⇒ page 222

WARNING

The intelligent technology in the City Safety Assist system cannot change the limits imposed by the laws of physics and by the system itself. The increased comfort offered by the City Safety Assist system should never prompt you to take risks. The driver always assumes the responsibility of braking in time.

- The City Safety Assist function can not individually prevent accidents, nor serious injury.
- The City Safety Assist system may carry out unwanted brake interventions in complex driving situations i.e. when a vehicle crosses at a short distance.

WARNING

Including the role of the City Safety Assist system in driving conduct may cause accidents and serious injury. The system is not a replacement for driver awareness.

- Always adapt your speed and the distance to the vehicles ahead in line with visibility, weather conditions, the condition of the road and the traffic situation.
- The City Safety Assist function does not react to people, animals or vehicles that cross or move in the opposite direction in the same lane.
- If after switching on the City Safety Assist function the vehicle begins to move, slow the vehicle with the foot brake.

CAUTION

If you suspect that the laser sensor of the City Safety Assist function is damaged, switch off the City Safety Assist function. This will avoid additional damage.

- Any reparation of the laser sensor requires specialist knowledge. SEAT recommends visiting a Technical Service. ►

Vehicle diagram

Prior to a journey...

While driving

Care, cleaning and maintenance

If and when

Technical Data

**Note**

If the City Safety Assist function activates a brake, the brake pedal range is reduced. This makes the brake pedal seem “harder”.

**Note**

Automatic brake intervention by the City Safety Assist function can be cancelled by pressing the clutch pedal, the accelerator pedal or by a corrective intervention.



**Note**






During the automatic braking by the City Safety Assist function you may hear unusual noises. This is normal and is produced in the brakes system. ■

Warning and control lamps

The City Safety Assist function is switched on every time the ignition is switched on. No special indication is produced.

If the City Safety Assist function is switched off, functions or there is an error in the system, this will be shown by a control lamp on the instrument panel display.

lights up	Possible cause ⇒ ⚠	Solution
 On	The City Safety Assist function has been switched on manually using the button  ⇒ Fig. 98.	The control lamp turns off after about 5 seconds.

flashes	Possible cause ⇒ ⚠	Solution
	<i>fast</i> : The City Safety Assist system function brakes automatically or has braked automatically.	Control lamp turns off automatically.
	<i>slow</i> : City Safety Assist function is not currently available.	If the vehicle is stopped, switch off the engine and switch it on again. If necessary, inspect the laser sensor (dirt, frozen) ⇒ ⚠ in Laser sensor on page 157. If it still does not function, refer to a Specialised workshop to have the system inspected.
 OFF	<i>within the operating area of 5-30- km/h (3-19 mph)</i> : The City Safety Assist function has been switched off manually using the button  ⇒ Fig. 98.	Switch on the City Safety Assist function manually using the button  ⇒ Fig. 98.

Several warning and control lamps light up for a few seconds when the ignition is switched on while a test of the function is being carried out. They will switch off after a few seconds.

**WARNING**

If the warning lamps are ignored, the vehicle may stall in traffic, or may cause accidents and severe injuries.

- Never ignore the warning lamps.
- Stop the vehicle safely as soon as possible.

**CAUTION**

Failure to heed the warning lamps when they appear may result in faults in the vehicle. ■

Laser sensor

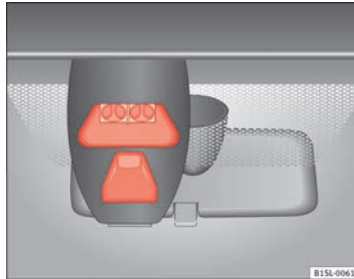


Fig. 96 On the windshield: City Safety Assist function laser sensor

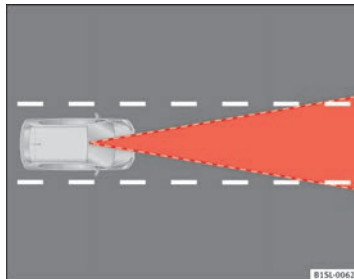


Fig. 97 Laser sensor detection area

A laser sensor on the windshield → Fig. 96 allows the system to detect driving situations in front of the vehicle.

Vehicles ahead can be detected up to a distance of about 10 m.

⚠ WARNING

The laser beam on the laser sensor can produce serious injuries to the eyes.

- Never focus optical devices, i.e. a camera, a microscope or a magnifying glass closer than 100 mm from the laser sensor.
- Note that the laser beam can stay active when the City Safety Assist system is switched off or unavailable. The laser beam is not visible to the human eye.

⚠ CAUTION

If the windshield is dirty or frozen in the area of the laser sensor, i.e. due to rain, mist or snow, the City Safety Assist system may subsequently fail to operate.

- Always keep the laser sensor area free of dirt and freezing.
- Use a small brush to remove snow and a de-icer spray to remove ice.

⚠ CAUTION

A damaged windshield in the laser sensor area may cause the City Safety Assist function to fail to operate.

- Replace the windshield if it is scratched, cracked or chipped by stones in the laser sensor area. Only use a windshield authorised by SEAT. Carrying out repairs is not permitted (i.e. in the case of damage suffered in an impact from a stone).
- When replacing the windshield wipers, only use windshield wipers authorised by SEAT.
- Do not paint the laser sensor area on the windshield, or cover it with adhesives, or sedimentation, etc.

Vehicle diagram

Prior to a journey...

While driving

Care, cleaning and maintenance

If and when

Technical Data


Function




Fig. 98 In the lower part of the centre console: Button for the City Safety Assist function

Switching on and off the City Safety Assist function

- Press the ⇒ Fig. 98 button on the centre console.

When the City Safety Assist function is switched on, the control lamp  OFF lights up on the instrument panel within the operational range, i.e. for speeds between 5-30 km/h (3-19 mph).

Switch off the City Safety Assist function in the following situations

Switching off the City Safety Assist function is recommended in the following situations ⇒ :

- While the vehicle is being towed.
- If the vehicle has been taken to an automatic car wash.
- If the vehicle is above a test bed.
- If the laser sensor is faulty.
- After the laser sensor has been involved in a collision.
- When driving off road (overhanging branches).
- If objects are protruding above the bonnet, i.e. a load carried on the roof that protrudes at the front.
- If the windscreen is damaged in the laser sensor area.



WARNING

Failure to switch off the City Safety Assist function in the above situations, may result in accidents and serious injury.

- Switch off the City Safety Assist function in critical situations. ■

Special driving situations

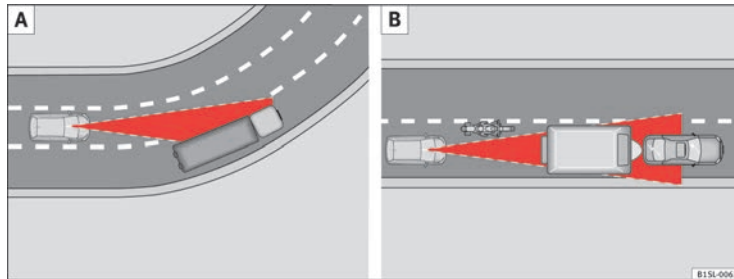


Fig. 99 A: Vehicle on a bend. B: Motorcyclist driving ahead out of range of the laser sensor

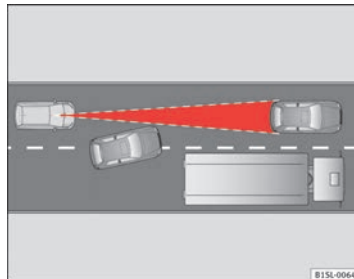


Fig. 100 Other vehicles changing lanes

The City Safety Assist function has physical limits, and has limits determined by the system itself. In certain circumstances, this may produce reactions from the City Safety Assist system, that are late or unexpected by the driver. For this reason, always pay due attention and if necessary, intervene.

For example, the following driving situations require special attention:

Driving through a bend

When entering or leaving a “long” bend, the vehicle may decelerate when the laser sensor detects a vehicle travelling in the opposite lane ⇒ Fig. 99 A. To interrupt the deceleration you can accelerate, turn the steering wheel or press the clutch.

Narrow vehicles in front

The laser sensor will only detect narrow vehicles in front if they are in the sensor detection zone ⇒ Fig. 99 B. This applies especially to narrow vehicles such as motorbikes.

Other vehicles changing lanes

Vehicles changing lane in close proximity can cause an unexpected brake from the City Safety Assist system ⇒ Fig. 100. To interrupt the deceleration you can accelerate, turn the steering wheel or press the clutch. ▶

Vehicle diagram

Prior to a journey...


While driving


Care, cleaning and maintenance

If and when

Technical Data

Malfunction in the laser sensor

If the laser sensor operation is impaired, for example due to heavy rain, spray, snow or dirt, the City Safety Assist system function is temporarily switched off. On the instrument panel display the control lamp  flashes.

When the fault in the laser sensor has been rectified, the City Safety Assist system function automatically becomes available. The control lamp  switches off.

The following conditions could prevent the City Safety Assist system from functioning:

- Tight bends.
- Accelerator pressed all the way down to the floor.
- If the City Safety Assist system is switched off or there is a fault ⇒ page 156.
- If the laser sensor is dirty, covered or overheated ⇒ page 157.
- In the event of snow, heavy rain or dense fog.
- If there are vehicles in front.
- Vehicles changing lanes.
- Vehicles moving in the opposite direction in the same lane.
- Very dirty vehicles with a low degree of reflection.
- Presence of thick dust.

Hill hold

Introduction

Additional information and warnings:

- SEAT information system ⇒ page 22
- Braking, stopping and parking ⇒ page 134

- Vehicle battery ⇒ page 193
- Wheels and tyres ⇒ page 210
- Accessories, parts replacement, repairs and modifications ⇒ page 222
- Hill hold ⇒ page 273






WARNING

The smart technology included in the hill hold cannot change the laws of physics. Do not let the extra convenience afforded by the hill hold tempt you into taking any risks when driving.

- Any accidental movement of the vehicle could result in serious injury.
- The hill hold is not a replacement for driver awareness.
- Adjust your speed and driving style to visibility, weather, road and traffic conditions.
- The hill hold cannot always keep the vehicle at a standstill on a slope or brake sufficiently when travelling downhill (e.g. on slippery or frozen surfaces).

Warning lamps

lights up	Possible cause	Solution
	The Start-Stop system is enabled.	
	The Start-Stop system is enabled but the engine cannot be automatically stopped.	Contact a Specialised workshop.
	The Start-Stop system cannot start the engine.	Start the engine by hand using the vehicle's key ⇒ page 120.
	There is a fault in the alternator.	⇒ page 193

flashes	Possible cause	Solution
(A)	The Start-Stop system is not available.	Contact a Specialised workshop.

Some warning and control lamps will light up briefly when the ignition is switched on to check certain functions. They will switch off after a few seconds.

WARNING

If the warning lamps are ignored when they light up, the vehicle may stall in traffic and cause accidents and severe injuries.

- Never ignore the warning lamps.
- Stop the vehicle at the next opportunity.

CAUTION

Failure to heed the control lamps when they light up may result in damage to the vehicle.

Start-Stop system

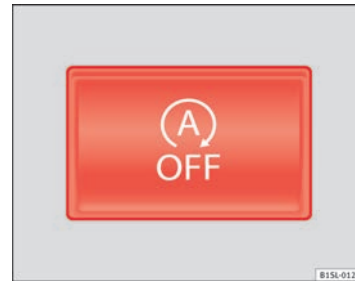


Fig. 101 At the top of the centre console: Start-Stop system button

With the Start-Stop system enabled, the engine is automatically stopped when the vehicle is at a standstill. It will start again automatically as required.

This function remains enabled while the ignition is switched on. The instrument panel display shows information on the current status ⇒ page 160.

Disconnect the Start-Stop system by hand whenever crossing water.

Vehicles with a manual gearbox

- When the vehicle is stopped, put it into neutral and release the clutch pedal. The engine will stop.
- To restart, simply engage the clutch.

Vehicles with an automatic gearbox

- When the vehicle is at a standstill, depress the brake or keep it pressed down. The engine switches off.
- The engine will start again as soon as you release the brake pedal.
- With the gear lever set to position **P**, the engine will not start until a range of gears is selected or the accelerator pedal is depressed.

Important conditions for the engine to stop automatically

- The driver's seat belt must be fastened.
- The driver door must be closed.
- The bonnet must be closed.
- The engine must have reached a minimum temperature.
- The vehicle must have moved since the last time the engine was stopped.
- The vehicle's battery must be sufficiently charged.
- The battery temperature must not be too low or too high.
- The vehicle must not be on a very steep slope.

Conditions for the engine to restart automatically

The engine can be automatically restarted in the following cases:


- If the vehicle starts to move.
- If the battery voltage drops.

Conditions requiring engine start-up using the key

The engine must be started by hand using the vehicle's key in the following cases:

- If the driver unbuckles his/her seat belt.
- If the driver door is opened.
- If the bonnet is opened.

Switching the Start-Stop system on and off

- Press the button  situated in the centre console ⇒ Fig. 101.
- The button will light up when the Start-Stop system is switched off.

The engine will start immediately if the vehicle is in Stop mode when the system is switched off by hand.



WARNING

The brake servo and the electromechanical steering do not work when the engine is switched off.

- **The vehicle must never be allowed to move with the engine switched off.**
- **Disconnect the Start-Stop system before working in the engine compartment.**



CAUTION

The vehicle's battery could be damaged if the vehicle is used for long periods at very high outside temperatures.



Note

In some cases, it may be necessary to start the engine by hand using the key. Refer to the corresponding control lamp on the instrument panel. ■

Hill-start aid*

This function is only included in vehicles with ESC.

This device helps when starting uphill. ▶

These are the basic operation conditions: doors closed, brake pedal pressed down and vehicle in neutral. The system gets activated on engaging gear.

After removing your foot from the brake pedal, the braking force is maintained for a few seconds to prevent the vehicle from moving backward when putting into gear. This short space of time is enough to start the vehicle with ease.

This system also works when reversing uphill.

**WARNING**

- If you do not start the vehicle immediately after taking your foot off the brake pedal, the vehicle may start to roll back under certain conditions. Depress the brake pedal or use the hand brake immediately.
- If the engine stalls, depress the brake pedal or use the hand brake immediately.
- When following a line of traffic uphill, if you want to prevent the vehicle from rolling back accidentally when starting off, hold the brake pedal down for a few seconds before starting off.

**Note**

The Official Service or a specialist workshop can tell you if your vehicle is equipped with this system. ■

Air control

Heating, Ventilation and Air conditioning system

Introduction

Dust and pollen filter

The dust and pollen filter with its activated charcoal cartridge serves as a barrier against impurities in the interior ambient air.

For the air conditioner to work with maximum efficiency, the dust and pollen filter must be replaced at the intervals specified in the Maintenance Programme.

If the filter loses efficiency prematurely due to use in areas with very high levels of air pollution, the filter must be changed more frequently than stated in the Service Schedule.

Additional information and warnings:

- SEAT information system ⇒ page 22
- Windscreen wash system ⇒ page 91
- Caring for and cleaning the vehicle exterior ⇒ page 197



WARNING

Reduced visibility through the windows increases the risk of serious accidents.

- Ensure that all windows are free of ice and snow and that they are not fogged up preventing a clear view of everything outside.



WARNING (Continued)

- The maximum heat output required to defrost windows as quickly as possible is only available when the engine has reached its normal running temperature. Only drive when you have good visibility.
- Always ensure that you use the heating system, ventilation, air conditioner and the heated rear window to maintain good visibility.
- Never leave the air recirculation on for a long period of time. If the cooling system mode is switched off and air recirculation mode switched on, the windows can mist over very quickly, considerably limiting visibility.
- Switch air recirculation mode off when it is not required.



WARNING

Stuffy or used air will increase fatigue and reduce driver concentration possibly resulting in a serious accident.


- Never leave the air fan turned off or use the air recirculation for long periods of time; the air inside the interior will not be refreshed.



CAUTION

- Switch the air conditioner off if you think it may be broken. This will avoid additional damage. Have the air conditioner checked by a specialised workshop.
- Repairs to the climate air conditioner specialist knowledge and special tools. SEAT recommends visiting a Technical Service. ▶

 **Note**

When the cooling system is turned off, air coming from the outside will not be dehumidified. To avoid fogging up the windows, SEAT recommends leaving the cooler (compressor) on. To do this, press the  button. The button indicator should light up.

 **Note**

The maximum heat output required to defrost windows as quickly as possible is only available when the engine has reached its normal running temperature.

 **Note**

Keep the air vents in front of the windscreen free of snow, ice and leaves to ensure heating and cooling are not impaired and to prevent the windows from misting over. ■

Controls

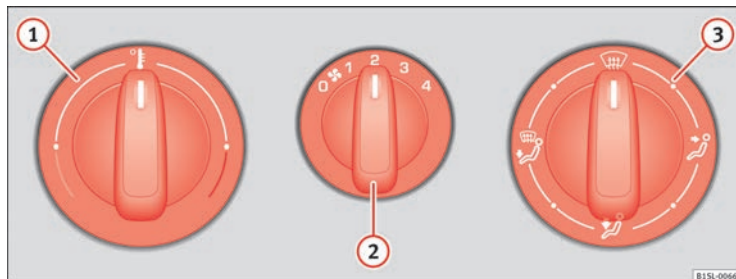


Fig. 102 In the centre console: Heating and ventilation system rotary control

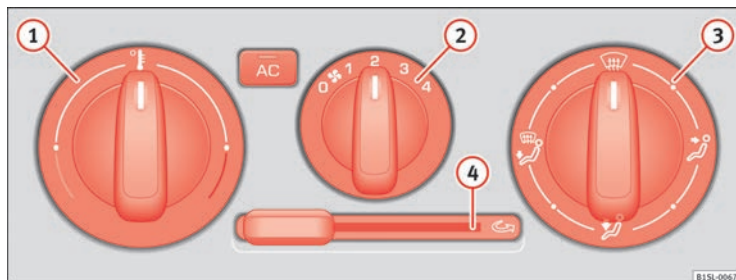













Fig. 103 In the centre console: Air conditioning system controls

Control button	Additional information. Heating and ventilation system ⇒ Fig. 102 and air conditioning system ⇒ Fig. 103.
	Temperature. Rotate the control to adjust the temperature accordingly.
	Air fan. setting 0: Air fan and air conditioning system switched off, setting 4: Air fan maximum setting.
	Air distribution. Rotate the continuous control to direct the airflow to the desired area.
	Heating and ventilation system: defrost function. Distribution of air to the windscreen and the side windows in the exterior rear vision mirror area. Air conditioning system: defrost function. Distribution of air to the windscreen and the side windows in the exterior rear vision mirror area. Press the  button, increase the air fan speed and switch on the air recirculation ⇒ page 169 to clear the windscreen of condensation as soon as possible.
	Air distribution towards the body.
	Air distribution towards the footwell.
	Air distribution towards the windscreen and the footwell.
AC	Air conditioner: press the button to turn off/on the cooling system ⇒ page 167.
	Air conditioner: sliding control for air recirculation ⇒ page 169.
	Switch off Turn the air fan switch  to position 0.

Heated rear window

The heated rear window button  is located on the centre console. The heated rear window only works when the engine is running and switches off automatically after a maximum of 10 minutes.



WARNING

Never turn off the air fan for a long time or the air in the interior will not be refreshed.




- **Stuffy or used air will increase fatigue and reduce driver and passenger concentration possibly resulting in a serious accident.**

Heating and ventilation system user instructions

Temperature

The desired temperature for the interior cannot be lower than that of the exterior air temperature, as the heating and ventilation system cannot cool or dehumidify the air.

Setting for conditions of optimal visibility

- Set the fan ⇒ Fig. 102  to setting 1 or 2.
- Turn the temperature control ⇒ Fig. 102  to the centre position.
- Open and direct the air outlets in the dash panel ⇒ page 169.
- Turn the air distribution control ⇒ Fig. 102  to the required position.


User instructions for the air conditioner*

The interior cooling system only works when the engine is running and fan is switched on.

The air conditioning operates most effectively with the windows closed. However, if the vehicle has heated up after standing in the sun for some time, the air inside can be cooled more quickly by opening the windows briefly.

Setting for conditions of optimal visibility

When the air conditioning system is switched on, the temperature and the air humidity in the vehicle interior drop. Hence, when the outside air humidity is high, the windows do not mist over and comfort for the vehicle occupants is improved:

- Disable air recirculation mode ⇒ page 169.
- Set the fan to the required setting.
- Turn the temperature control to the centre position.
- Open and direct the air outlets in the dash panel ⇒ page 169.
- Turn the air distribution control to the defrost position.
- Press the  button to turn on cooling. The button will light up.

The cooling system does not switch on

If the air conditioning system cannot be switched on, this may be caused by the following:

- The engine is not running.
- The fan is switched off.
- The air conditioner fuse has blown.
- The outside temperature is lower than approximately +2 °C (+36 °F).
- The air conditioner compressor has been temporarily switched off because the engine coolant temperature is too high.
- Another fault in the vehicle. Have the air conditioner checked by a specialised workshop.

Things to note

If the humidity and temperature outside the vehicle are high, **condensation** can drip off the evaporator in the cooling system and form a pool underneath the vehicle. This is normal and does not indicate a leak!



Note

After starting it, any residual humidity in the air conditioner could mist over the windscreen. Switch on the defrost function as soon as possible to clear the windscreen of condensation. ■

Air vents



Fig. 104 Dash panel: Air vents

Air vents

Never close the air vents ⇒ Fig. 104 **A** completely to ensure heating, cooling and ventilation inside the vehicle.

- To open the air vents press the recess with one slat.
- Change the air direction by turning the slats.
- To close the air vents, fold the slats.

There are additional air vents in the centre of the dash panel and in the foot-well area.



CAUTION

Never place food, medicines or other heat-sensitive objects close to the air vents. Food, medicines and other heat-sensitive objects may be damaged or made unsuitable for use by the air coming from the air vents. ■

Air recirculation

Important

Air recirculation mode prevents the ambient air from entering the interior.

When the outside temperature is very high or very low, selecting manual air recirculation mode for a short period refreshes or heats the interior more quickly.

- Switch off air recirculation mode by turning the air distribution control to the ⇒ position.

Switching the air recirculation mode on and off

Switching on: Move the sliding control ⇒ Fig. 103 **4** to the right to maximum.

Switching off: Move the sliding control ⇒ Fig. 103 **4** as far left as possible. ▶

**WARNING**

Stuffy or used air will increase fatigue and reduce driver concentration possibly resulting in a serious accident.

- Never use recirculation mode for long periods as it does not refresh the air inside the vehicle.
- If the cooling system mode is switched off and air recirculation mode switched on, the windows can mist over very quickly, considerably limiting visibility.
- Switch air recirculation mode off when it is not required.

**CAUTION**

Do not smoke when the air recirculation is activated. The smoke taken in could lie on the cooling system vaporiser and on the dust and pollen filter, leading to a permanently unpleasant smell. ■

At the filling station

Refuelling

Introduction

The fuel tank plug is on the rear right of the vehicle.

Additional information and warnings:

- Exterior detail → page 6
- Fuel → page 177
- Working in the engine compartment → page 180

WARNING

Refuelling or handling fuel carelessly can cause an explosion or fire resulting in serious burns and injuries.

- Always make sure that you correctly close the fuel tank flap to avoid evaporation and fuel spillage.
- Fuels are highly explosive and inflammable substances that can cause serious burns and injuries.
- Fuel could leak out or be spilt if the engine is not switched off or if the filler fuel nozzle is not fully inserted into the tank filler mouth when refuelling. This could lead to a fire, explosion and severe injuries.
- When refuelling, turn off the engine and turn off the ignition for safety reasons.
- Always turn off mobile telephones, radio system apparatus and other radio wave emitting equipment before refuelling. Electromagnetic waves could cause sparks and lead to a fire.

WARNING (Continued)

- Never enter the vehicle while refuelling. If it is absolutely necessary to enter the vehicle, close the door and touch a metal surface before touching the filler nozzle again. This will prevent the generation of static electricity. Sparks could cause a fire when refuelling.
- Never handle fuel close to open flames, sparks or objects with slow combustion (e.g. cigarettes).
- Avoid static electricity and electro-magnetic radiation when refuelling.
- Observe the safety regulations of the service station.
- Never spill fuel on the vehicle or in the luggage compartment.

WARNING

For safety reasons, SEAT does not recommend carrying a spare fuel canister in the vehicle. Fuel could be spilled and catch fire, above all in case of an accident and this applies to a full container as well as empty containers. This could lead to explosions, fires and injuries.

- Observe the following if you exceptionally have to carry fuel in a canister:
 - Never place a fuel container, to fill it, inside the vehicle or on the vehicle, for example, in the luggage compartment. Filling in these circumstances could create an electrostatic charge and spark that could ignite fuel fumes.
 - Always place the canister on the ground to fill it.
 - Insert the fuel nozzle into the mouth of the canister as far as possible.

⚠ WARNING (Continued)

- If you are using a metal fuel canister, the nozzle must always touch the canister while it is being filled to avoid static electricity.
- Follow the legal requirements for the use, storage and transport of spare fuel canisters.
- Insure that the fuel container complies with manufacturing standards, for example, ANSI or ASTM F852-86.

! CAUTION

- Always remove any fuel spilled anywhere on the vehicle to avoid damage to the wheel housing, the tyre and vehicle paintwork.
- Refuelling a petrol engine with diesel can cause serious engine and fuel system damage; the resulting malfunctions are not covered by the SEAT warranty. If you refuel with the wrong type of fuel, never start the engine. This applies to even the smallest amount of the wrong fuel. You should obtain professional assistance. With the engine running, the composition of the wrong fuel could significantly damage the fuel system and the engine itself.

**For the sake of the environment**

Fuels can contaminate the environment. Collect any spilt service fluids and allow a professional to dispose of them. ■

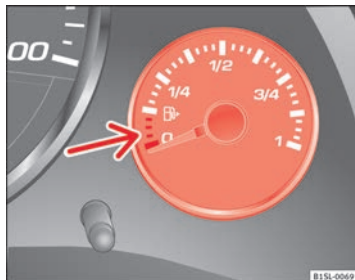
Control lamps and fuel gauge

Fig. 105 On the instrument panel: fuel gauge for petrol

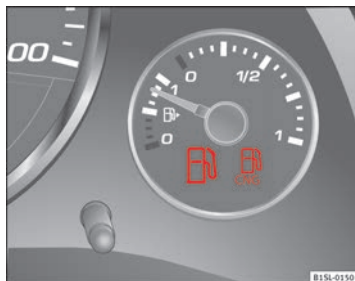






Fig. 106 On the instrument panel: fuel gauge for petrol

The fuel gauge can vary depending on the vehicle equipment ⇒ Fig. 105 or ⇒ Fig. 106. ►

lights up	Gauge position ⇒ Fig. 105	Possible cause ⇒ ⚠	Solution
 a)	Red mark (arrow)	The fuel tank is almost empty. The reserve tank is being used ⇒ page 290.	Refuel as soon as possible ⇒ Ⓞ.
	–	The vehicle is running in natural gas operating mode.	–


a) This only applies to vehicles with the fuel gauge on the instrument panel ⇒ Fig. 105.


flashes for about 10 seconds	State of the bars	Possible cause ⇒ ⚠	Solution
 and the segments remaining ^{a)}	Reserve zone (four small segments)	The fuel tank is almost empty. The reserve tank is being used ⇒ page 290.	Refuel as soon as possible ⇒ Ⓞ.
	–	The vehicle is running in natural gas operating mode.	–


a) This only applies to vehicles with the fuel gauge on the instrument panel display.

Several warning and control lamps light up for a few seconds when the ignition is switched on while a test of the function is being carried out. They will switch off after a few seconds.

In natural gas engines

The warning lamp  lights up when both fuel types (petrol and natural gas) have reached reserve level.

The warning lamp  lights up when the vehicle is running in natural gas operating mode.

The warning lamp  switches off when the natural gas is exhausted. The engine changes to operate with petrol.

Problem: If the vehicle is left parked for a long time immediately after refuelling, the gas level indicator does not accurately indicate the same level shown after refuelling when the vehicle is started up again. This is not due to a leak in the system, but to a drop in pressure in the gas tank for technical reasons after a cooling phase immediately after refuelling.

⚠ WARNING

Driving with insufficient fuel reserve could result in the vehicle breaking down in traffic and a serious accident.

- If the fuel level is too low then the fuel supply to the engine can become irregular especially on slopes.
- If the engine “is choked” or stalls due to lack of or irregularity of the fuel supply, the power steering as well as all of the driver assistance systems including braking assistance will stop working.
- Always refuel when there is only one quarter of the fuel tank left to avoid running out of fuel.

ⓘ CAUTION

- Always pay attention to any lit lamps and to the corresponding descriptions and instructions to avoid damage to the vehicle.
- Never run the fuel tank completely dry. An irregular fuel supply may lead to ignition faults and unburnt fuel could enter the exhaust system. This could damage the catalytic converter.

ⓘ Note

The arrow next to the fuel pump symbol on the instrument panel ⇒ Fig. 105 indicates the side of the vehicle on which the fuel tank plug is located. ■

Refuelling with petrol

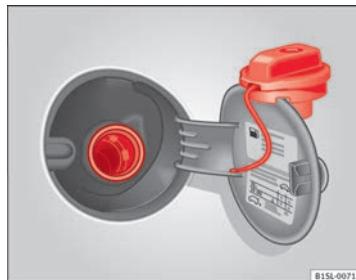


Fig. 107 Open fuel tank flap with tank plug attached to the holder

Before refuelling, always turn off the engine, the ignition, mobile telephones, auxiliary heating and keep them off during refuelling.

Opening the fuel tank flap

- The fuel tank plug is at the rear of the vehicle on the right.
- Pull the rear zone of the fuel tank flap to open.
- Unfold the key shaft if necessary ⇒ page 28.
- Insert the vehicle key into the lock cylinder of the fuel tank plug and turn the key in an anticlockwise direction.
- Take out the fuel tank plug by turning it in an anticlockwise direction and rest it on the upper part of the fuel tank flap ⇒ Fig. 107.

Refuelling

The correct petrol type for the vehicle is located on a sticker inside the fuel tank flap ⇒ page 177.

- If the automatic filler nozzle is operated correctly, it will switch itself off as soon as the fuel tank is *full* ⇒ ⚠.
- Do not continue to refuel if it is turned off! Otherwise, this will fill the expansion chamber and fuel may leak out if the ambient conditions are warm.

Closing the fuel tank flap

- Screw on the fuel tank filler plug in a clockwise direction until it is fully inserted with a click.
- Insert the vehicle key into the lock cylinder of the fuel tank plug, turn the key in a clockwise direction and remove the key.
- Press the tank flap until it clicks into place. The fuel tank flap must be flush with the body contour.



WARNING

Do not continue refuelling once the fuel nozzle has switched itself off. The fuel tank may be filled too much. As a result, fuel may spurt out and spill. This could lead to a fire, explosion and severe injuries.



CAUTION

- Always remove any fuel spilled anywhere on the vehicle to avoid damage to the wheel housing, the tyre and vehicle paintwork.



For the sake of the environment

Fuels can contaminate the environment. Collect any spilt service fluids and allow a professional to dispose of them. ■

Refuelling with natural gas

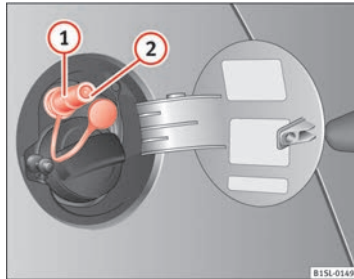


Fig. 108 Tank flap open:
gas filler mouth ①, filler
mouth retainer ②


Before refuelling, the engine and the ignition, mobile telephone and heating must be switched off separately ⇒ ⚠.

It is also essential to carefully read the instructions for the natural gas pump.

The vehicle is not prepared for refuelling with liquefied natural gas (LNG) ⇒ ⚠. Before refuelling with natural gas, make sure to add the appropriate type of fuel.

Opening the fuel tank cap

The natural gas filler mouth is behind the fuel tank cap, next to the petrol filler mouth.

- Unlock the vehicle with the key or with the central locking button  situated on the driver door ⇒ page 36.
- Press on the rear area of the flap and open it.

Refuelling

Problem: If the ambient temperature is very high, the natural gas pump protection against overheating disconnects this automatically.

- Remove the plug from the gas filler mouth ⇒ Fig. 108 ①.
- Connect the pump filling nozzle to the gas filler mouth.
- The fuel tank will be *full* when the pump compressor automatically cuts the supply.
- If you wish to finish refuelling in advance, press the button on the pump to stop the flow.

Closing the fuel tank flap

- Check that the gas filler mouth retainer ② is not trapped with the filler nozzle. If necessary, place it in the filler mouth again.
- Insert the plug in the filler mouth.
- Close the tank flap. Make sure you hear it click into place.

WARNING

Natural gas is a highly explosive, easily flammable substance. Incorrect handling of the natural gas can cause accidents serious burns and other injuries.

- Before refuelling with natural gas, the filling mouth must be correctly engaged. If you can smell gas, stop refuelling immediately.

WARNING

The vehicle is not prepared to use liquefied natural gas (LNG) and this fuel must not be added under any circumstances. Liquefied natural gas can cause the natural gas tank to explode resulting in serious injury. ▶

**Note**

- The filling nozzles of natural gas pumps can differ in the way they are operated. If you are unacquainted with the pump, it is advisable that a member of staff of the service station performs the refuelling operation.
- Noises heard when refuelling are normal and do not indicate the presence of a fault in the system.
- The vehicle natural gas system is prepared both for refuelling with a small compressor (slow refuel) and a large compressor (fast refuel) in natural gas service stations.

Information on bulb replacement ⇒ page 264.

Refuelling precautions

Checklist

Never work on the engine or in the engine compartment if you are not familiar with the operations to be carried out, the applicable safety standards and if you do not have the instruments, liquids and tools necessary ⇒ page 180, Working in the engine compartment! In such a case, have any work carried out by a Specialised workshop. Check the following regularly, preferably when you refuel:

- ✓ Windscreen washer fluid level ⇒ page 91
 - ✓ Engine oil level ⇒ page 185
 - ✓ Engine coolant level ⇒ page 189
 - ✓ Brake fluid level ⇒ page 134
 - ✓ Tyre pressure ⇒ page 210
 - ✓ Vehicle lighting required to guarantee road safety:
 - Turn signals
 - Side lights, dipped beam and main beam headlights
 - Rear lights
 - Brake lights
 - Rear fog light ⇒ page 84
-


Fuel

Introduction

You will find a factory-fitted sticker containing information on the type of fuel for your vehicle on the inside of the fuel tank flap.

Additional information and warnings:

- ⇒ Booklet Maintenance Programme
- Refuelling ⇒ page 171
- Electronic power control and exhaust gases purification system ⇒ page 236

 WARNING	
Refuelling or handling fuel carelessly can cause an explosion or fire resulting in serious burns and injuries.	
<ul style="list-style-type: none"> • Fuel is a highly explosive, easily flammable substance. • Observe current safety instructions and local regulations concerning the handling of fuel. 	

Types of fuel

The type of fuel to use when refilling will depend on the vehicle's engine. You will find a factory-fitted sticker containing information on the type of fuel for your vehicle on the inside of the fuel tank flap.


SEAT recommends the use of sulphur-free or low sulphur fuel to reduce consumption and prevent engine damage.

Possible types of fuel	Alternative names	Further information
91 ^{a)} RON	Normal petrol, normal unleaded petrol	⇒ page 177
95 ^{a)} RON	Premium unleaded petrol (95 RON)	
98 ^{a)} RON	Premium unleaded petrol (98 RON)	

^{a)} RON = Regulation Octane Number

Petrol

Petrol types


Vehicles with petrol engines must refuel using unleaded petrol according to European norm EN 228 ⇒ .

Petrol types are categorised according to their octane number (e.g. 91, 95, 98 or 99 RON (RON = "Research Octane Number"). You may use petrol with a high octane number than the one recommended for your engine. However, this has no advantage in terms of fuel consumption and engine power.

SEAT recommends refuelling with a low sulphur content or sulphur-free fuel to reduce fuel consumption for petrol engines.

Petrol additives

The quality of the fuel influences running behaviour, performance and service life of the engine. Therefore, it is recommended to refuel with good quality petrol containing the corresponding petrol additives. These additives will help to prevent corrosion, keep the fuel system clean and prevent deposits from building up in the engine.

If good quality petrol with additives are not available or engine problems arise, the necessary additives must be added when refuelling ⇒ .

Not all petrol additives have been shown to be effective. The use of unsuitable petrol additives could seriously damage the engine and the catalytic converter. Petrol additives with metal additives must never be used.

Available petrol additives for improvements in Anti-detonation ratings or octane ratings may contain metal additives ⇒ Ⓞ.

SEAT recommends "Genuine SEAT Additives for petrol engines". These additives are available from Specialised workshops, who will inform you of their application.

⚠ CAUTION

- Only use fuel with an octane rating that is in line with the norm EN 228, otherwise significant damage could be caused to the engine and fuel system. Furthermore, it could lead to a loss of performance with the consequent engine fault.
- The use of unsuitable petrol additives could seriously damage the engine and the catalytic converter.
- If, in exceptional circumstances, petrol with a lower octane rating to that recommended is used, only use moderate engine speeds and a light throttle. Avoid using full throttle and overloading the engine. Otherwise engine damage may occur. Fill up with fuel of a suitable octane rating as soon as possible.
- Do not refuel if the filler indicates that the fuel contains metal. LRP (lead replacement petrol) fuels also contain high concentrations of metal additives. This could damage the engine!
- Just filling one full tank of leaded fuel or with other metal additives would seriously impair the efficiency of the catalytic converter and could damage it.

Natural gas

Natural gas, in addition to others, can be in liquid form.

Liquefied natural gas (LNG) is the result of heavy cooling of natural gas. Therefore its volume is considerably reduced compared with compressed natural gas (CNG). In vehicles with a natural gas engine, liquefied natural gas cannot be directly refilled, given that the gas would expand excessively in the vehicle gas tank.

Therefore, vehicles with a natural gas engine must only be refuelled using compressed natural gas ⇒ ⚠.

Natural gas quality and consumption

Natural gas is divided into the groups H and L depending on its quality.

Gas type H has a superior heating power and inferior nitrogen and carbon dioxide content than type L. The higher the heating power of the natural gas, the lower the consumption will be.

However, the heating power and the proportion of nitrogen and carbon dioxide can fluctuate within the quality groups. Therefore, vehicle consumption can also vary when using one type of gas only.

The engine management automatically adapts to the natural gas used according to its quality. Therefore, different quality gases can be mixed in the tank, without the need for comprehensive draining before applying a different quality gas.

Natural gas and safety

If you can smell gas or suspect that there is a leak ⇒ ⚠:

- Stop the vehicle immediately.
- Switch the ignition off.
- Open the doors to appropriately ventilate the vehicle.
- Immediately extinguish cigarettes.
- Move away from the vehicle or switch off objects that may cause sparks or a fire.
- If you continue to smell gas, do not continue driving!
- You should obtain professional assistance. Have the fault repaired. ▶

**WARNING**

Failure to act when you can smell gas in the vehicle or when refuelling can cause serious injuries.

- Carry out the necessary operations.
- Leave the danger zone.
- If necessary, warn the emergency services.

**WARNING**

The vehicle is not prepared to use liquefied natural gas (LNG) and this fuel must not be added under any circumstances. Liquefied natural gas can cause the natural gas tank to explode resulting in serious injury.

**Note**

The natural gas system must be subject to regular inspections at a specialised workshop in accordance with the Service Plan. ■

Care, cleaning and maintenance

In the engine compartment

Working in the engine compartment

Introduction

Before working in the engine compartment, make sure that the vehicle is parked on horizontal and firm ground.

The engine compartment of the vehicle is a hazardous area. Never work on the engine or in the engine compartment if you are not familiar with the operations to be carried out, the applicable safety standards and especially if you do not have the instruments, liquids and tools necessary ⇒ ⚠! In such a case, have any work carried out by a Specialised workshop. Negligent work can cause serious injury.

Additional information and warnings:

- Exterior detail ⇒ page 6
- Windscreen wash system ⇒ page 91
- Start and stop the engine ⇒ page 119
- Brake fluid ⇒ page 134
- Checks when filling up ⇒ page 171
- Engine oil ⇒ page 185
- Engine coolant ⇒ page 189
- Vehicle battery ⇒ page 193
- Accessories, parts replacement, repairs and modifications ⇒ page 222



WARNING

If the vehicle moves unexpectedly, this could cause serious injury.


- Never work underneath the vehicle if it is not secured against moving. If you must work underneath the vehicle with the wheels in contact with the ground then it should be parked on flat ground, the wheels should be prevented from moving and the key must be removed from the ignition.
- If you have to work underneath the vehicle, you must use suitable stands additionally to support the vehicle, there is a risk of accident!. The jack is not intended for this kind of work and its failure could lead to severe injuries.
- Disconnect the Start-Stop system.



WARNING

The engine compartment is a dangerous area capable of causing serious injury.

- For all type of work, always take the utmost precautions, work carefully and note the general safety standards in force. Never take personal risks.
- Never work on the engine or in the engine compartment if you are not familiar with the necessary operations. If you are not sure about procedures then visit a Specialised workshop to carry out the necessary work. Incorrect work can cause serious injuries.

 **WARNING (Continued)**

- Never open the bonnet if you see steam or coolant escaping from the engine compartment. Hot vapours and coolant can cause serious burns. Always wait until you cannot see or hear the sound of steam or coolant coming from the engine compartment.
- Always allow the engine to cool down before opening the bonnet.
- Contact with hot elements of the engine and the exhaust system can cause burns.
- Once the engine has cooled, follow the instructions below before opening the bonnet:
 - Engage the handbrake and place the gear selector lever in P or the gear stick in neutral.
 - Remove the key from the ignition.
 - Keep children away from the engine compartment and never leave them unsupervised.
- When the engine is warm or hot, the cooling system is pressurised. Do not unscrew the cap on the coolant expansion tank when the engine is hot. Otherwise, coolant may spray out under pressure causing burns and serious injury.
 - After cooling, carefully and slowly unscrew the cap anticlockwise, gently pressing down on it.
 - Always protect your face, hands and arms from hot coolant and steam using a large, thick cloth.
- When refilling liquids, avoid spilling them on parts of the engine and the exhaust system. Spilled liquids could cause a fire.

 **WARNING**

The high voltages of the electrical system can give electric shocks as well as causing burns and serious injury and possibly even death!

- Never cause short circuits in the electrical system. The battery could explode.
- To minimise the risk of electric shock and serious consequences while the engine is running or starting the engine, note the following:
 - Never touch the electrical wiring of the ignition system.

 **WARNING**

In the engine compartment, there are rotating parts that could cause serious injury.

- Never place your hands directly on or near the radiator fan. Touching the rotor blades could seriously harm you. The ventilator works according to the engine temperature and could start suddenly even when the ignition is turned off and the key is removed.
- If any work has to be performed when the engine is started or with the engine running, there is an additional, potentially fatal, safety risk from the rotating parts, such as the drive belts, alternator, radiator fan etc as well as from the high-voltage ignition system. Always work with the utmost caution.
 - Always make sure that no parts of your body, jewellery, ties, loose clothing and long hair can be trapped by the rotating parts of the engine. Before any work, remove ties and jewellery (necklaces, etc), tie longhair back and tie all items of loose clothing to your body to make sure that they cannot be trapped by engine components.
 - Take extreme caution when operating the accelerator and remain attentive. The vehicle could move, even if the handbrake is applied.
- Always make sure you have not left any objects, such as cloths or tools, in the engine compartment. If any object is left in the engine compartment, this could cause malfunctions, engine faults and even a fire. ▶

**WARNING**

Refill liquids and certain materials can catch fire easily in the engine compartment, causing a fire and serious injury!

- Never smoke.
- Never work close to places exposed to flames or sparks.
- Never pour service fluids over the engine. These fluid may ignite hot engine parts and cause injuries.
- If it is necessary to work on the fuel system or the electrical system, please follow the instructions below:
 - Always disconnect the vehicle battery.
 - Never work close to heaters, heat sources or places exposed to flames or sparks.
- Always keep a recently serviced and perfectly working fire extinguisher close by.

**CAUTION**

When refilling or changing service liquids, ensure that you put the liquids into the right tank. Making a mistake when refilling could cause serious malfunctions and damage the engine!

**For the sake of the environment**

Service fluids leaks are harmful to the environment. For this reason you should make regular checks on the ground underneath your vehicle. Take the vehicle to a Specialised workshop to be checked if you see stains, oil or other fluids on the ground. Collect any spilt service fluids and allow a professional to dispose of them. ■

Preparing the vehicle for work in the engine compartment**Checklist**

Carry out the operations below in the order indicated before starting work in the engine compartment ⇒ ⚠:

- ✓ Park the vehicle on an even and solid surface.
- ✓ Press and hold the brake pedal until the vehicle comes to a standstill.
- ✓ Apply the handbrake firmly ⇒ page 134.
- ✓ Move the gear lever into the neutral position ⇒ page 124.
- ✓ Stop the engine and remove the key from the ignition ⇒ page 119.
- ✓ Wait for the engine to cool down.
- ✓ Always keep children and other people far from the engine compartment.
- ✓ Ensure that the vehicle can not move off unexpectedly.

**WARNING**

Always complete the operations given in the checklist and observe the general rules of safety.

- Ignoring this checklist, drawn up for your own safety, could result in serious injury. ■

Opening and closing the bonnet

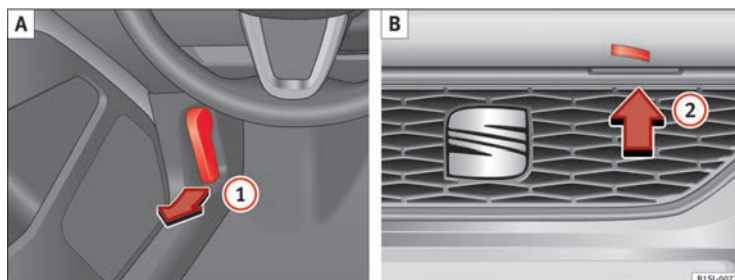


Fig. 109 A: Release lever in the footwell on the driver side B: Release lever on the bonnet

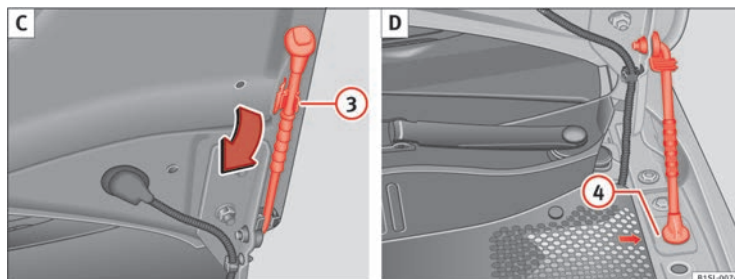


Fig. 110 C: Bonnet securing rod in the bonnet. D: Bonnet supported by the bonnet securing rod

Vehicle diagram

Prior to a journey...

While driving

Care, cleaning and maintenance

If and when

Technical Data

Opening the bonnet

- Before opening the bonnet, make sure that the windscreen wiper arms are in place against the windscreen ⇒ ①.
- Pull the release lever ① in the direction of the arrow ⇒ Fig. 109 A. The bonnet is released from the lock carrier by a spring mechanism ⇒ ⚠.
- Lift the bonnet up slightly while pressing the release lever ② B in the direction of the arrow to completely open the bonnet.
- Take out the bonnet support rod from its clip in the direction of the arrow ③ C and place it in the corresponding open position ④ D (arrow).

Closing the bonnet

- Slightly lift the bonnet ⇒ ⚠.
- Take out the bonnet support rod from the opening catch ④ D and insert it into its clip ③ C in the opening catch.
- Let the bonnet fall from a height of 30 cm into its clip; Do *not* apply pressure!

If the bonnet is not correctly closed, open it once again and close it correctly.

The bonnet is correctly closed when it is flush with the corresponding parts on the bodywork.

**WARNING**

If the bonnet is not correctly closed, it could suddenly open while driving leaving the driver without visibility. This could result in serious accident.

- After closing the bonnet, always check that it is properly secured by the locking mechanism in the lock carrier piece. The bonnet must be flush with the surrounding body panels.
- While driving, if you notice that the bonnet is not correctly closed then stop immediately and close it correctly.
- Only open and close the bonnet when there is nobody within its range.

**CAUTION**

- To avoid damage to the bonnet and to the windscreen wiper arms, only open the bonnet when the windscreen wipers are in place against the windscreen.
- Before driving, always lower the windscreen wiper arms. ■

Engine oil

Introduction

Additional information and warnings:

- ⇒ Booklet Maintenance Programme
- Working in the engine compartment ⇒ page 180
- Accessories, parts replacement, repairs and modifications ⇒ page 222

WARNING

Incorrectly handling engine oil can cause injury and serious burns.



- Always protect your eyes when handling engine oil.
- Oil is toxic and must be kept out of the reach of children.
- Engine oil must only be kept closed in its original container. The same applies to use oil until it has been disposed of.
- Never store engine oil in empty food containers or bottles as other people may accidentally drink it.
- Regular contact with engine oil can be bad for the skin. If you come into contact with engine oil, wash your skin with soap and water.
- With the engine running, the engine oil gets extremely hot and can cause severe skin burns. Always wait until the engine has fully cooled.



For the sake of the environment

Similar to the other service liquids, spilled engine oil can be bad for the environment. Collect any spilt fluids in suitable containers and dispose of in accordance with legislation and with the utmost respect for the environment.

Warning and control lamps

flashes	Possible cause	Solution
	Engine oil pressure too low.	<p> Stop the vehicle! Switch off the engine. Check the engine oil level, and if necessary, refill with ⇒ page 186. engine oil - If the warning indicator flashes although the oil level is correct, do <i>not</i> continue driving or leave the engine running. Otherwise, the engine could be damaged. You should obtain professional assistance.</p>

WARNING

If the warning lamps are ignored, the vehicle may stall in traffic, or may cause accidents and severe injuries.

- Never ignore the warning lamps.
- Stop the vehicle safely as soon as possible.

CAUTION

Failure to heed the warning lamps when they appear may result in faults in the vehicle.

Engine oil specifications

Replacement engine oil must strictly comply with the specifications. ▶

The correct oil must be used to ensure the correct operation and long service life of the engine. The engine comes with a high-quality multigrade oil that can generally be used all year round.

Only use an engine oil that complies to SEAT standards whenever possible ⇒ ①. Only refill engine oil using approved engine oil in accordance with the corresponding SEAT standard (⇒ table on page 186). All oils indicated are **synthetic multigrade oils**.

Engine oils are being continuously further developed. Technical Services are permanently informed of any modifications. SEAT therefore recommends that you have the engine oil changed by a Technical Service.

Engines	Specifications of engine oil with a service dependent on time/distance travelled
44 kW - 55 kW Petrol engines	VW 504 00, VW 502 00

⚠ CAUTION

- Only use engine oils whose specifications are expressly approved by SEAT. The use of any other type of engine oil could cause engine damage!
- No additives should be used with engine oil. Any damage caused by the use of such additives would not be covered by the factory warranty. ■

Checking the engine oil level and topping up

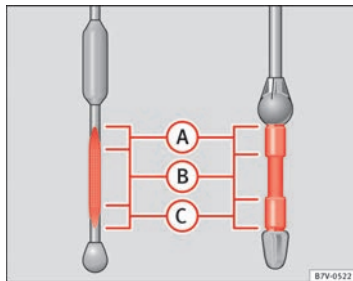




Fig. 111 Marked engine oil dipstick



Fig. 112 In the engine compartment: Engine oil filler cap

Preparations






- Park the vehicle on flat ground so that the engine oil reading is correct.
- The engine must be hot to be able to check the engine oil level. Stop the engine and wait a few minutes for the oil to drain back into the sump. ▶

- Open the bonnet  ⇒ page 180.
- The engine oil filler mouth can be recognised by the symbol  on the cap ⇒ Fig. 112 and the dipstick by its coloured handle.

Check the engine oil level


- Pull out the dipstick and wipe it on a clean cloth.
- Replace the dipstick, pushing it in as far as it will go. If the dipstick to measure engine oil has a mark, when you reintroduce it this mark should slot into the corresponding groove located on the upper end of the tube.
- Remove the dipstick again and check the engine oil level ⇒ table on page 187.
- After reading the oil level, replace the dipstick in the tube completely.


Engine oil topping up ranges

Fig. 111	Operations required depending on the engine oil topping up level:
Area 	Do not top up oil ⇒  .
Area 	You can add oil, but keep the level in this zone.
Area 	Oil must be added. After topping up the oil level should be in area  .

Adding oil after checking the level

Only add engine oil in small quantities and in steps.

- Unscrew the cap from engine oil filler mouth on the cylinder head ⇒ Fig. 112. If you are not sure where the cap is, request help from a specialist.
- Only refill using approved SEAT engine oil in small quantities (no more than 0.5 ltr) ⇒ page 185.
- To avoid adding too much oil, each time you add a quantity, wait until the oil has flowed into the crankcase so that it can be measured with the dipstick.
- Check the oil level before adding any more oil. Do not top up with too much engine oil ⇒ .


- When the oil level is in at least the ⇒ Fig. 111  zone, insert the dipstick into the tube fully to avoid engine oil escaping when the engine is running.
- After topping up the oil, ensure that the cap is screwed on to the filler mouth correctly.

WARNING

Oil could catch fire if it comes into contact with hot engine components. This could lead to a fire, explosion and severe injuries.


- **Always ensure that after topping of oil, the engine oil filler cap is correctly tightened. This will avoid engine oil spilling onto hot engine parts when the engine is running.**

CAUTION

- If the engine oil level is above the area  do not start the engine. You should obtain professional assistance. Otherwise catalytic converter and engine damage may occur.
- When refilling or changing service liquids, ensure that you put the liquids into the right tank. Making a mistake when refilling could cause serious malfunctions and damage the engine!




For the sake of the environment

The oil level must never be above area . Otherwise oil can be drawn in through the crankcase breather and escape into the atmosphere via the exhaust system. ■

Engine oil consumption

The consumption of engine oil can be different from one engine to another and can vary during the useful life of the engine. ▶

Depending on how you drive and the conditions in which the vehicle is used, oil consumption can be up to 1 ltr./2000 km. In the case of new vehicles, the consumption can exceed this figure over 5000 kilometres. For this reason the engine oil level must be checked at regular intervals, preferably when filling the tank and before a journey.

When the engine is working hard, for instance during sustained high-speed motorway cruising in summer, or when climbing mountain passes, the oil level should preferably be kept within area ⇒ Fig. 111 .

Changing the engine oil

The engine oil must be changed regularly according to the specifications of the Maintenance Programme.

Due to the problems linked with disposing of used oil and the need for suitable tools and special knowledge, always visit a Specialised workshop to have the engine oil and filter changed. SEAT recommends visiting a Technical Service.

Detailed information on the service intervals are shown in the Maintenance Programme.

Engine oil additives make new oil darker after the engine has been running for a short period. This is normal and does not mean more frequent oil changes are required.



WARNING

If, in exceptional circumstances, you must change the engine oil yourself, please note the following:

- Wear eye protection.



WARNING (Continued)

- Always wait until the engine has completely cooled to avoid being burned.
- Always keep your arms horizontal when unscrewing the oil drainage bolt so that the oil does not run down your arms when it begins to drain.
- Use a suitable and large enough container to collect all of the used oil in the engine.
- Never collect engine oil in empty food containers, cans, bottles and other containers as not all people are able to identify engine oil.
- Oil is toxic and must be kept out of the reach of children.



For the sake of the environment

Before changing the engine oil, find a suitable location or service for proper disposal.




For the sake of the environment

Always dispose of engine oil with the utmost respect for the environment. Never dispose of used engine oil in places such as a garden, woods, drains, roads, paths, rivers and drainage systems.

Engine coolant

Introduction

Never work on the engine cooling system or if you are not familiar with the operations to be carried out, the applicable safety standards and especially if you do not have the instruments, liquids and tools necessary ⇒ ! In such a case, have any work carried out by a Specialised workshop. SEAT recommends visiting a Technical Service.

Negligent work can cause serious injury.

Additional information and warnings:

- Working in the engine compartment ⇒ page 180
- Accessories, parts replacement, repairs and modifications ⇒ page 222

WARNING

Engine coolant is toxic!

- Only keep engine coolant in its original container, tightly shut and in a safe place.
- Never store engine coolant in empty food containers or bottles as other people may accidentally drink it.
- Always keep engine coolant out of reach of children.
- Ensure that the proportion of engine coolant additive corresponds to the lowest outside temperature to which the vehicle will be exposed.
- If the outside temperature is extremely low, the engine coolant could freeze causing the vehicle to stop. As this would also cause the heating to stop working, vehicle occupants without sufficient clothing could freeze.







For the sake of the environment

Coolants and additives can contaminate the environment. Collect any spill fluids in suitable containers and dispose of in accordance with legislation and with the utmost respect for the environment. ■

Coolant warning lamp

Several warning and control lamps light up for a few seconds when the ignition is switched on while a test of the function is being carried out. They will switch off after a few seconds.

lights up	Possible cause	Solution
	Excessive engine coolant temperature.	 Stop the vehicle! Stop the vehicle safely as soon as possible. Switch off the engine and let it cool.
	Insufficient engine coolant level.	 Stop the vehicle! Check the engine coolant when the engine has cooled and, if it is low, refill with engine coolant ⇒ page 191.
flash-es	Engine coolant system faulty.	 Do not drive any further. Obtain professional assistance.
	Engine coolant system faulty.	You should obtain professional assistance. ▶

**WARNING**

If the warning lamps are ignored, the vehicle may stall in traffic, or may cause accidents and severe injuries.

- Always observe any lit warning lamps.
- Never ignore the warning lamps.
- Stop the vehicle safely as soon as possible.

**CAUTION**

Failure to heed the warning lamps when they appear may result in faults in the vehicle.

**Note**

On the display of the Portable Navigation System (supplied by SEAT) ⇒ page 222 an engine coolant temperature gauge can be seen.

Engine coolant specifications

The engine cooling system is supplied from the factory with a specially treated mixture of water and, at least, 40 % of the additive **G 13** (TLVW 774). The engine coolant additive is recognisable by its purple colour. This mixture of water and additive gives the necessary frost protection down to -25 °C (-13 °F) and protects the light alloy parts of the cooling system against corrosion. It also prevents scaling and considerably raises the boiling point of the coolant.

To protect the engine cooling system, the percentage of additive must always be at least 40 %, even in warm climates where anti-freeze protection is not required.

If greater frost protection is required in very cold climates, the proportion of additive can be increased. However, the percentage of additive should not

exceed 60 %, as this would reduce the frost protection and, in turn, decrease the cooling capacity.

When the coolant is topped up, use a mixture of **distilled water** and, at least, 40 % of the G 13 or G 12 plus-plus (TL-VW 774 G) additive (both are purple) to obtain an optimum anticorrosion protection ⇒ ①. The mixture of G 13 with G 12 plus (TL-VW 774 F), G 12 (red) or G 11 (green-blue) engine coolants will significantly reduce the anticorrosion protection and should, therefore be avoided ⇒ ①.

**WARNING**

If there is not enough anti-freeze in the coolant system, the engine may fail leading to serious damage.

- Please make sure that the percentage of additive is correct with respect to the lowest expected ambient temperature in the zone in which the vehicle is to be used.
- When the outside temperature is very low, the coolant could freeze and the vehicle would be immobilised. In this case, the heating would not work either and inadequately dressed passengers could die of cold.

**CAUTION**

The original additives should never be mixed with coolants which are not approved by SEAT. Otherwise, you run the risk of causing severe damage to the engine and the engine cooling system.

- If the fluid in the expansion tank is not purple but is, for example, brown, this indicates that the G 13 additive has been mixed with an inadequate coolant. The coolant must be changed as soon as possible if this is the case! This could result in serious faults and engine damage.

**For the sake of the environment**

Coolants and additives can contaminate the environment. If any fluids are spilled, they should be collected and correctly disposed of, with respect to the environment.

Checking the engine coolant level and refilling

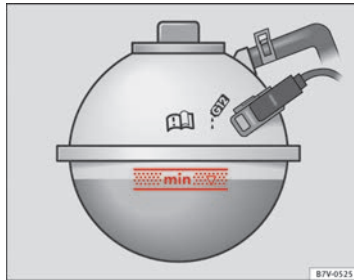





Fig. 113 In the engine compartment: Marking on coolant expansion tank



Fig. 114 In the engine compartment: Coolant expansion tank cap

If the coolant level is low, the coolant warning indicator will light.





Preparations

- Park the vehicle on even, flat and firm ground.
- Allow the engine to cool ⇒ .
- Open the bonnet  ⇒ page 180.
- The coolant expansion tank is easily recognisable because of the symbol  on the cap ⇒ Fig. 114.

Checking the engine coolant level

- When the engine is cold, check the coolant level using the side marking on the expansion tank ⇒ Fig. 113.
- If the level is below the "MIN" mark, top up with coolant. When the engine is hot it may be slightly above the marked area.

Topping up the engine coolant level

- Always protect your face, hands and arms from hot coolant and steam using a large, thick cloth over the coolant expansion tank cap.
- Remove the cap very carefully ⇒ .
- Only refill using **new** engine coolant according to SEAT specifications (⇒ page 190) ⇒ .
- The engine coolant level should be between the marks on the coolant expansion tank ⇒ Fig. 113. **Do not exceed the top level of the marked area** ⇒ .
- Screw on the cap tightly.
- If, the event of an emergency, you have no coolant that is compliant to the required specifications (⇒ page 190), never use another type of additive. Instead, first top up with **distilled water** ⇒  only. Then re-establish the correct proportion of the mixture with the correct additive as soon as possible ⇒ page 190.

**WARNING**

Hot vapours and coolant can cause serious burns.

- **Never open the coolant expansion tank if steam or coolant is coming from the engine compartment. Wait until you cannot see or hear any steam or coolant escaping.**
- **Always wait until the engine has completely cooled before very carefully opening the expansion tank cap. Contact with hot elements of the engine can cause skin burns.**
- **Once the engine has cooled, follow the instructions below before opening the bonnet:**
 - Engage the handbrake and place the gear selector lever in P or the gear stick in neutral.
 - Remove the key from the ignition.
 - Keep children away from the engine compartment and never leave them unsupervised.
- **When the engine is warm or hot, the cooling system is pressurised. Do not unscrew the cap on the coolant expansion tank when the engine is hot. Otherwise, coolant may spray out under pressure causing burns and serious injury.**
 - Carefully and slowly unscrew the cap anticlockwise, gently pressing down on it.
 - Always protect your face, hands and arms from hot coolant and steam using a large, thick cloth.
- **When refilling liquids, avoid spilling them on parts of the engine and the exhaust system. Spilled liquids could cause a fire. Under specific circumstances, the ethylene glycol can catch fire.**

**CAUTION**

- Top up with distilled water only. Any other type of water may lead to considerable rusting in the engine due to its chemical components. This could consequently damage the engine. If you have not used distilled water but another type of water to top up the coolant, a Specialised workshop must immediately replace all of the fluid in the engine cooling system.
- Only top up coolant to the top level of the marked area ⇒ Fig. 113. Otherwise the excess coolant will be forced out of the cooling system when the engine is hot, causing damage.
- If a lot of liquid coolant has been lost, wait for the engine to *cool down completely* before adding coolant. Extensive coolant loss is an indication of leaks in the engine cooling system. Have the engine cooling system inspected immediately by a Specialised workshop. Otherwise engine damage may occur.
- When refilling or changing service liquids, ensure that you put the liquids into the right tank. Making a mistake when refilling could cause serious malfunctions and damage the engine! ■

Vehicle battery

Introduction






The battery is a component of the vehicle's electrical system.

Never work on the electrical system without fully understanding the operations required, the applicable safety standards and without the correct tools ⇒ ⚠! In such a case, have any work carried out by a Specialised workshop. SEAT recommends visiting a Technical Service. Negligent work can cause serious injury.

Location of the vehicle battery

The battery is located in the engine compartment.

Explanation of the warning indications on the vehicle's battery

Symbol	Meaning
	Wear eye protection!
	Battery acid is very corrosive and caustic. Always wear protective gloves and eye protection!
	Fires, sparks, open flames and smoking are prohibited.
	A highly explosive mixture of gases is released when the battery is under charge.
	Keep children away from acid and batteries!

Additional information and warnings:

- ⇒ Booklet Maintenance Programme
- Working in the engine compartment ⇒ page 180
- Accessories, parts replacement, repairs and modifications ⇒ page 222

WARNING

Working on the vehicle battery and the electrical system can cause corrosion, fire and electric shocks. Always read and take into account the following warnings and safety standards before carrying out any work:

- Before working on the battery, switch off the engine, the ignition and all electrical devices then disconnect the negative connection on the battery.
- Keep children away from acid and the battery itself!
- Wear eye protection.
- Battery acid is very corrosive and caustic. It can burn skin and cause blindness. When handling the battery, protect yourself from splashes of acids, above all your hands, arms and face.
- Do not smoke and never work close to places exposed to flames or sparks.
- Avoid sparks and electrostatic discharges when working with cables and electrical devices.
- Never short the battery terminals.
- Never use a damaged battery. It can explode. Replace a damaged battery immediately.
- Replaced damaged or frozen batteries as soon as possible. A flat battery can also freeze at temperatures close to 0 °C (+32 °F).

CAUTION

- Never disconnect the battery if the ignition is switched on or if the engine is running. This could damage the electrical system or electronic components.
- Do not expose the battery to direct sunlight over a long period of time, as the intense ultraviolet radiation can damage the battery housing.
- If the vehicle is left standing for long periods, protect the battery from extreme cold temperature so that it does not "freeze up" and become damaged.

Vehicle diagram

Prior to a journey...


While driving

Care, cleaning and maintenance

If and when

Technical Data

Warning lamp

lights up	Possible cause	Solution
	Faulty generator.	Contact a Specialised workshop. Have the electrical system checked. Disconnect any unnecessary electrical consumers. The generator does not charge the battery while the vehicle is in motion.

Several warning and control lamps light up for a few seconds when the ignition is switched on while a test of the function is being carried out. They will switch off after a few seconds.



WARNING

If the warning lamps are ignored, the vehicle may stall in traffic, or may cause accidents and severe injuries.

- Never ignore the warning lamps.
- Stop the vehicle safely as soon as possible.



CAUTION

Failure to heed the warning lamps when they appear may result in faults in the vehicle.

Checking the electrolyte level of the vehicle battery

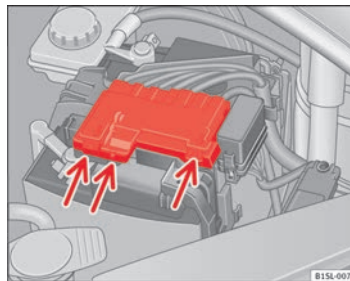



Fig. 115 In the engine compartment: Remove the cover from the vehicle's battery

The battery's electrolyte level should be checked regularly in high-mileage vehicles, in hot countries and in older batteries. Other batteries do not require maintenance.

Vehicles fitted with the Start-Stop system are equipped with special batteries. For technical reasons, the electrolyte level cannot be checked in these batteries.

Preparations

- Prepare the vehicle for work in the engine compartment ⇒ page 180
- Open the bonnet  ⇒ page 180.
- Press on the tabs ⇒ Fig. 115 (arrows) in the direction of the arrows and lift the battery cover up.

Checking the battery electrolyte level

- Make sure there is sufficient lighting to clearly recognise the colours. Never use open flames or sparklers as a light source.
- Depending on the level of acid, the Magic eye on the top of the battery will change colour. ▶

Colour indicator	Necessary operations
<i>light yellow or colourless</i>	The electrolyte level of the vehicle's battery is too low. Have the battery checked and, where applicable, replaced by a Specialised workshop.
<i>black</i>	The electrolyte level of the vehicle's battery is correct.


WARNING

Working with the vehicle battery involves a risk of corrosion, explosions and electric shock.

- Always wear protective gloves and eye protection.
- Battery acid is very corrosive and caustic. It can burn skin and cause blindness. When handling the battery, protect yourself from splashes of acids, above all your hands, arms and face.
- Never tilt the vehicle battery. Battery acid could spill out of the openings to release gases and cause corrosion damage.
- Never open the vehicle battery.
- If battery acid splashes on you, immediately rinse your eyes and skin abundantly with water for several minutes. Then seek medical care immediately.
- If acid is swallowed by mistake, consult a doctor immediately.

Charging, replacing and connecting or disconnecting the battery

Charging the battery

The vehicle battery should be charged by a specialised workshop only, as batteries using special technology have been installed and they must be charged in a controlled environment ⇒ . SEAT recommends visiting a Technical Service.

Replacing a vehicle battery


The battery has been developed to suit the conditions of its location and has special safety features. If the battery must be replaced, consult a Technical Service for information on electromagnetic compatibility, the size and maintenance, performance and safety requirements of the new battery in your vehicle before you purchase one. SEAT recommends you have the battery replaced by a Technical Service.

Use only maintenance-free genuine batteries conforming to TL 825 06 and VW 7 50 73 Standards. These standards must be dated April 2008 or later.


Vehicles fitted with the Start-Stop system are equipped with a special battery. Therefore, this battery must only be replaced by another of the same specifications.

Disconnecting the vehicle's battery

If you must disconnect the battery from the electrical system, please note the following:

- Switch off the ignition and all electrical equipment.
- The vehicle must be unlocked before disconnecting the battery, otherwise the alarm will be triggered.
- First disconnect the negative cable and then the positive ⇒ .

Connecting the vehicle's battery

- Before reconnecting the battery, switch off the engine, the ignition and electric devices.
- First reconnect the positive cable and then the negative ⇒ .

Different control lamps may light up after connecting the battery and switching the ignition on. They will be turned off after a short trip at a speed of between 15 - 20 km/h (10 - 12 mph). If the warning indicators remain lit, please visit a specialised workshop to have the vehicle checked.

If the battery has been disconnected for a long time, it is possible that the next service date is not displayed or calculated correctly ⇒ page 17. Respect ►

the maximum service intervals permitted ⇒ Booklet Maintenance Programme.

Automatic consumer disconnection

The intelligent vehicle electrical system automatically implements a range of measures to prevent the battery from discharging when high demands are made on it:

- the idling speed is increased so that the alternator provides more electricity.
- where necessary, the power of the most powerful consumers is reduced or even completely disconnected.
- On starting the engine, the power supply from the 12-volt socket and the cigarette lighter may be interrupted for a short time.

The on-board management program cannot always prevent the battery from running flat. For example, if the ignition is left on for a long period with the engine off or if the side lights or parking lights are left on while the vehicle is stationary.

Why the battery runs flat:

- When stationary for a long time without starting the engine, particularly if the ignition is switched on.
- Use of electrical consumers with the engine switched off.

WARNING

Incorrectly securing the battery or using the wrong battery can cause short-circuits, fire and serious injuries.

- **Always use only maintenance free batteries, protected to prevent a leak, and whose properties, specifications and size correspond to the standard battery.**

WARNING

A highly explosive mixture of gases is released when the battery is under charge.

- **The batteries should be charged in a well-ventilated room only.**
- **Never charge a frozen or recently thawed battery. A flat battery can also freeze at temperatures close to 0 °C (+32 °F).**
- **Always replace a battery which has frozen.**
- **Battery cables not correctly connected may cause a short circuit. Reconnect first the positive cable and then the negative cable.**

CAUTION

- Never disconnect the battery if the ignition is switched on or if the engine is running. This could damage the electrical system or electronic components.
- Never plug accessories supply current, such as solar panels or a battery charger, to the 12-volt socket or the cigarette lighter. This could damage the vehicle's electrical system.



For the sake of the environment

Dispose of the battery in an environment-friendly manner. Batteries contain toxic substances such as sulphuric acid and lead.



For the sake of the environment

Battery acid can contaminate the environment. Collect any spilt service fluids and allow a dispose of them correctly. ■

Vehicle care and maintenance

Care and cleaning the vehicle exterior

Introduction

Regular maintenance and washing help to **maintain the value** of the vehicle. This may also be one of the requirements for acknowledging warranty claims in the event of bodywork corrosion or paint defects.

Products suitable for the care of your vehicle are available at any Technical Service.

Additional information and warnings:

- Working in the engine compartment ⇒ page 180
- Care and cleaning of the vehicle interior ⇒ page 205
- Accessories, parts replacement, repairs and modifications ⇒ page 222

WARNING

Vehicle care products may be toxic and hazardous. If vehicle care products are not suitable or are used inappropriately, this could result in accident, serious injury, burns or intoxication.

- Vehicle care products must always be stored in the original container which should be kept closed.
- Observe information provided by the manufacturer.
- To prevent confusion, never store vehicle care products in empty food cans, bottles or other containers.
- Keep all care products out of reach of children.

WARNING (Continued)

- Harmful vapours may be produced when using vehicle care products. Therefore, care products should only be used in well-ventilated spaces or in the open air.
- Never use fuel, turpentine, engine oil, acetone or any other volatile liquid to wash, clean or care for the vehicle. These are toxic and highly flammable.

WARNING

Inappropriate care and cleaning of vehicle components may effect the vehicle safety equipment, increasing the risk of severe injury.

- Vehicle components should only be cleaned and maintained in accordance with the manufacturer's instructions.
- Only use approved or recommended care products.

CAUTION

Cleaning products which contain solvents will damage the material.

For the sake of the environment

Only wash the vehicle in areas allocated for this purpose, to prevent dirty water which may be contaminated by oil, grease or fuel, from entering the drains. In some districts, washing vehicles outside wash bays is prohibited.

For the sake of the environment

Where possible, always use products which respect the environment. ▶



For the sake of the environment

The remains of vehicle care products should not be disposed of with ordinary household waste. Observe information provided by the manufacturer. ■

Washing the vehicle

The longer substances such as insects, bird droppings, resinous tree sap, road dirt, industrial deposits, tar, soot or road salt and other aggressive materials remain on the vehicle, the more damage they do to the paintwork. High temperatures (for instance due to strong sunlight) further intensify the corrosive effect. The vehicle **undercarriage** should also be thoroughly washed at regular intervals.

Automatic car washes

Always observe the instructions provided at the automatic car wash. The standard precautionary measures prior to entering the car wash should be taken to avoid damage to the vehicle (close all windows, fold in exterior mirrors). If the vehicle is fitted with additional components (spoiler, roof-rack, aerial...), check with the car wash supervisor whether these can enter the car wash ⇒ ①.

The vehicle paintwork is so durable that the vehicle can normally be washed without problems in an automatic car washing tunnel. However, wear and damage to the paintwork will depend on the type of car wash used. SEAT recommends the use of car washes without brushes.

To remove traces of wax on windows and to prevent wiper blades from scratching, please observe the following ⇒ page 200, Cleaning windows and exterior mirrors.

Washing the vehicle by hand

When washing the vehicle by hand, use plenty of water to soften the dirt first, and rinse off as well as possible.

Then clean the vehicle with a soft **sponge, glove or brush** using only slight pressure. Start at the roof and work downwards. Special **vehicle shampoo** should only be used for very persistent dirt.

Rinse the sponge or glove thoroughly and often.

Wheels, sills and similar should be cleaned last. Use a second sponge for this.



WARNING

Sharp components on the vehicle may cause injury.

- **Protect arms and hands from sharp edges when cleaning the vehicle undercarriage or the interior of the wheel hubs.**



WARNING

After the vehicle has been washed, the braking effect will be reduced (and the braking distance increased) due to moisture (and ice in winter) on the brakes.

- **“Dry the brakes and remove ice” by braking carefully. Ensure that you are not endangering other road-users or breaking traffic regulations in the process.**



CAUTION

- The temperature of the water must not exceed +60 °C (+140 °F).
- To avoid damage to the paintwork, do not wash the vehicle in full sun.
- Do not use rough sponges or similar which could damage the surface to clean away the traces of insects.
- Never wipe the headlights with a dry cloth or sponge, always moisten first. It is best to use soapy water.
- Washing the vehicle in low temperatures: When washing the vehicle with a hose, do not direct water into the lock cylinders or the gaps around the doors, rear lid, or sunroof. Locks and seals could freeze! ▶

⚠ CAUTION

To prevent damage to the vehicle, please observe the following before entering an **automatic car wash**:

- Compare the distance between the vehicle wheels and the distance between the guide-rails of the car wash to prevent damage to the wheels and tyres!
- Switch off the rain sensor before taking the vehicle to an automatic car wash.
- Compare the height and width of your vehicle with the available height and width when entering and driving through the car wash!
- Fold in exterior mirrors Electrically retractable exterior mirrors must NOT be folded in or out by hand. Always use the electrical power control.
- To avoid damaging the bonnet paintwork, rest the windscreen wipers on the windscreen after drying the wiper blades. Do not let them fall!
- Lock the rear lid to prevent it from opening unexpectedly while inside the car wash. ■

Washing the vehicle with high pressure cleaning apparatus

When cleaning the vehicle with a high-pressure cleaner, always follow the operating instructions for the equipment. Pay special attention to the required **pressure** of the jet and the **distance** between the jet and the vehicle ⇒ ⚠.

Keep a suitable distance from soft materials, such as rubber hoses or insulating material, and from the parking distance warning system sensors. The sensors of the parking distance warning system are situated on the rear bumper ⇒ Ⓞ.

Do not use a nozzle that sprays the water out in a **direct stream** or one that has a **rotating jet** for forcing off dirt ⇒ ⚠.

⚠ WARNING

The incorrect use of high pressure cleaning equipment could result in permanent damage, visible or invisible, to the tyres or other materials. This could result in serious accident.

- Ensure there is a suitable distance between the nozzle and the tyres.
- Never wash tyres with a concentrated jet or so-called "dirt blasters". Even at large spraying distances and short cleaning times, you may damage the tyres.

⚠ WARNING

After the vehicle has been washed, the braking effect will be reduced (and the braking distance increased) due to moisture (and ice in winter) on the brakes.

- "Dry the brakes and remove ice" by braking carefully. Ensure that you are not endangering other road-users or breaking traffic regulations in the process.

⚠ CAUTION

- The temperature of the water must not be above +60 °C (+140 °F).
- To avoid damage to the paintwork, do not wash the vehicle in full sun.
- To ensure that the system functions well, the sensors located on the bumper must be kept clean and free from ice. When cleaning with pressure hoses and steam cleaners, the sensors should be sprayed only briefly. A distance of 10 cm between the sensors and the steam / hose nozzle must be observed.
- Do not use a high pressure cleaner to remove ice or snow from windows
- Washing the vehicle in low temperatures: When washing the vehicle with a hose, do not direct water into the lock cylinders or the gaps around the doors, rear lid, or sunroof. Locks and seals could freeze! ■

Vehicle diagram

Prior to a journey...

While driving

Care, cleaning and maintenance

If and when

Technical Data

Cleaning windows and exterior mirrors

Cleaning windows and exterior mirrors

Spray windows and exterior windows with a standard window cleaner containing alcohol.

Dry the windows with a clean chamois leather or a lint-free cloth. The chamois leathers used on painted surfaces are not suitable for cleaning windows because they are soiled with wax deposits which could smear the windows.

Use window cleaner or a silicone remover to clean rubber, oil, grease and silicone deposits off ⇒ ⑩.

Removing wax deposits

Automatic car washes and certain vehicle care products may leave **wax deposits** on the windows. These deposits can only be removed with a special product or cleaning cloths. If wax deposits are left on the windscreen and the rear window, the blades can scratch the glass. SEAT recommends you wipe the wax deposits off the windscreen and the rear window with a soft cloth each time after you have washed the vehicle.

A window cleaning detergent which helps to dissolve the wax may be added to the windscreen washer fluid to prevent the wiper blades from scratching the windscreen. Please ensure the you add the cleaning product in the correct proportions. Products for removing grease do not eliminate the wax deposits ⇒ ⑩.

Special cleaning products or window cloths are available at any Technical Service. To remove wax deposits, SEAT recommends the following products:

- For the hottest time of the year: the window cleaner for summer use G 052 184 A1. Proportion 1:100 (1 part detergent, 100 parts water) in the windscreen washer bottle.
- All year round: the window cleaner G 052 164 A2; proportion 1:2 in windscreen washer bottle (1 part concentrate, 2 parts water) in winter, up to -18 °C (-0.4 °F), or 1:4, during the rest of the year.
- Window cloths G 052 522 A1 for all windows and exterior mirrors.

Removing snow

Use a small brush to remove snow from the windows and exterior mirrors.

Removing ice

If possible, use a de-icing spray to remove ice. If you use an ice scraper, push it in one direction only **without** swinging it. If you pull the scraper backwards, the dirt may scratch the window.



WARNING

Dirty or misted windows reduce visibility in all directions and increase the risk of accident and serious injury.

- **Do not drive unless you have good visibility through all windows!**
- **Remove ice and snow from the windows and demist inside and out.**



CAUTION

- Never mix our cleaning products with other products not recommended by SEAT in the windscreen washer bottle. This could lead to flocculation and may block the windscreen washer jets.
- Do not use hot or warm water to remove ice or snow from the windows and exterior mirrors. The glass could crack!
- The heating element for the rear window is located on the inner side of the window. Do not stick adhesive labels over the heating elements and never clean the inside of the rear window with corrosive or acid products or other similar chemical cleaning products. ■

Cleaning and changing windscreen wiper blades

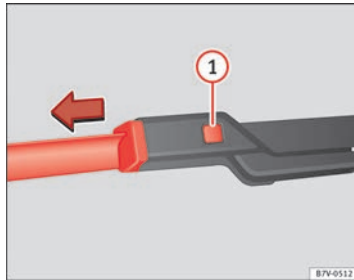


Fig. 116 Changing the front windscreen wiper blades

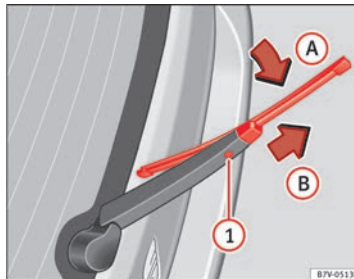


Fig. 117 Changing the rear wiper blade

The windscreen wiper blades are supplied as standard with a layer of graphite. This layer is responsible for ensuring that the wipe is silent. If the graphite layer is damaged, the noise of the water as it is wiped across the windscreen will be louder.

Check the condition of the wiper blades regularly. **If the wipers scrape across the glass** they should be changed if they are damaged, or cleaned if they are dirty ⇒ ①.

Damaged wiper blades should be replaced immediately. Blades are available from Specialised workshops.

Lifting and unfolding the wiper arms

The wiper arm may **only** be lifted at the point where it is fastened to the blade.

For windscreen wipers, please note: the windscreen wiper should be in service position before unfolding it ⇒ page 91.

Cleaning windscreen wiper blades

- Lifting and unfolding the wiper arms.
- Use a soft cloth to remove dust and dirt from the windscreen wiper blades.
- If the blades are very dirty, a sponge or damp cloth may be used ⇒ ②.

Changing the front windscreen wiper blades

- Lifting and unfolding the wiper arms.
- Hold down the release button ⇒ Fig. 116 ① while gently pulling the wiper blade in the direction of the arrow.
- Fit a new wiper blade of the **same length and design** on to the wiper arm and hook it into place.
- Rest the wiper arms back onto the windscreen.

Changing the rear wiper blade

- Lift the windscreen wiper arm and fold it at an angle of approximately 60° ⇒ Fig. 117.
- Press and hold the release button ①.
- Fold the wiper blade towards the windscreen wiper arm ⇒ Fig. 117 (arrow A) while simultaneously pulling in the direction of arrow B). This may require some strength. ▶

- Insert a new blade of the **same length and type** in the windscreen wiper arm in the opposite direction to the arrow (B) and hook into place. This feature is operational when the blade is in position (arrow (A)).
- Return the windscreen wiper arm to the windscreen. Do not let it simply drop down!

**WARNING**

Worn or dirty wiper blades reduce visibility and increase the risk of accident and serious injury.

- **Always replace damaged or worn blades or blades which do not clean the windscreen correctly.**

**CAUTION**

- Damaged or dirty windscreen wipers could scratch the glass.
- If products containing solvents, rough sponges or sharp objects are used to clean the blades, the graphite layer will be damaged.
- Never use fuel, nail varnish remover, paint thinner or similar products to clean the windows.

**Note**

If wax deposits, other cleaning products from the automatic car wash, or other care products, are left on the windscreen and the rear window, the blades can scratch the glass. Remove wax deposits with a special product or cleaning cloths.

Caring for and polishing the vehicle paintwork

Waxing

Regular waxing protects the paintwork. It is time to apply a good coat of *wax* when water no longer **forms droplets** and rolls off the **clean** paintwork.

Even if a **wax solution** is used regularly in the automatic car wash, SEAT recommends protecting the paint with a hard wax coating at least twice a year.

Polishing

Polishing is only necessary if the paint has lost its shine, and the gloss cannot be brought back by applying wax.

If the polish does not contain wax, a wax product should be applied after polishing.

**CAUTION**

- To prevent damage, vehicle polish or hard wax should not be used on components painted in matt paint, plastic components and the glass headlamp and tail light covers.
- Do not polish your vehicle in a sandy or dusty environment.

Care and cleaning of chrome and aluminium wheel rims

- Use a clean, damp, lint-free, smooth cloth to clean anodized surfaces.
- If there is a lot of dirt, use a special cleaning product which does not contain **solvents**.
- Then, polish the chrome and aluminium wheel trims with a smooth dry cloth.

**CAUTION**

In order to prevent damage to the aluminium and chrome wheel trims:

- Do not clean or polish them in direct sunlight.
- Do not clean or polish them in sandy or dusty environments.
- Do not use abrasive cleaning agents such as home cream cleaners.
- Do not use insect sponges, scouring pads, or similar products to clean insect deposits.

- Do not polish dirty surfaces.
- Do not use products containing solvents.
- Do not use hard wax.

**CAUTION**

Chrome hub caps or wheel covers may have been painted additionally. Do not treat them with aluminium or chrome wax products, nor chrome or aluminium polish. Instead, use commercial paint wax or polish. ■

Cleaning wheels

Cleaning steel wheels

Use an industrial cleaner to remove brake dust. Therefore, clean wheel rims regularly with a separate sponge.

Any damage to the paint on steel wheel rims should be touched up before the metal starts to rust.

Caring for and cleaning alloy wheels

Remove road salt and brake dust by washing the wheels approximately **once a fortnight**. Use an acid free detergent to clean the wheel rims. SEAT recommends treating the wheel rims thoroughly with a **hard wax** about once every three months.

It is important to remove road salt and brake dust by washing the wheels at regular intervals, otherwise the finish will be impaired.

Always use an acid-free detergent for alloy wheel rims. Vehicle polish or other abrasive agents should not be used.

If the protective coating on the paint has been damaged (for example, hit by a stone), it should be repaired immediately. ■

Caring for rubber seals

The rubber seals on doors, windows, etc., remain flexible, provide a better seal and last longer if they are regularly treated with a product specifically designed for use on rubber.

Before applying the product, use a soft cloth to remove dust and dirt from the rubber seals. ■

De-icing the door lock cylinder

To de-ice the lock cylinders, SEAT recommend the use of genuine SEAT spray with lubricating and anti-corrosive properties.

**CAUTION**

The use of products containing degreasing agents to de-ice the locks may rust the lock cylinder. ■

Protection of vehicle undercarriage

The vehicle underbody is coated to protect it from chemical and mechanical damage. The protective coat on the undercarriage may wear through use while driving. Therefore, SEAT recommends that the protective coating on the undercarriage and on the running gear should be regularly checked, and repaired if necessary. ►

**WARNING**

Additional underseal or anti-corrosion products could catch fire due to the high temperatures reached by the exhaust gas system and other engine components.

- Do not apply additional underseal or anti-corrosion products to the exhaust pipes, catalytic converters, heat shields or other parts of the vehicle which reach high temperatures.

**WARNING**

When working on the engine or in the engine compartment, there is a risk of injury, burns, accident or fire.

- Before starting work, please ensure you are familiar with the required procedure and the safety precautions ⇒ page 180.
- SEAT recommends you have this work performed by a specialised workshop.

Cleaning the engine compartment

The engine compartment of any motor vehicle is a potentially hazardous area ⇒ page 180.

The engine compartment should only be cleaned by qualified personnel. If it is not correctly cleaned, the anti-corrosion coating and consequently electrical components may be damaged. Moreover, water may filter directly into the vehicle interior through the water chamber ⇒ ①.

If the engine compartment is very dirty, always take the vehicle to a Specialised workshop for professional cleaning. SEAT recommends visiting a Technical Service.

Water box

The water box is in the engine compartment, between the windscreen and the engine, and beneath a perforated cover. Air is taken in through the water box from outside to the vehicle interior via the heating and air conditioning system.

Leaves and other loose objects should be regularly cleaned away from the water box either by hand or with a vacuum.

**CAUTION**

If water is manually poured into the water box (for example, using a high pressure cleaning appliance), this could cause significant damage to the vehicle.

**For the sake of the environment**

Only wash the engine compartment in areas allocated for this purpose, to prevent dirty water which may be contaminated by oil, grease or fuel, from entering the drains. In some districts, the engine compartment may not be washed outside the wash bays provided for this purpose.

Caring for and cleaning the vehicle interior

Introduction

The dye from many items of modern clothing (e.g. dark jeans) is not always solid enough. Seat upholstery (material and leather), especially when light-coloured, may visibly discolour if the dye comes out of clothing (even when used correctly). This is not an upholstery defect but indicates that the dye in the item of clothing is not solid enough.

Additional information and warnings:

- Caring for and cleaning the vehicle exterior ⇒ page 197
- Accessories, parts replacement, repairs and modifications ⇒ page 222



WARNING

Vehicle care products may be toxic and hazardous. If vehicle care products are not suitable or are used inappropriately, this could result in accident, serious injury, burns or intoxication.

- Vehicle care products must always be stored in the original container which should be kept closed.
- Observe information provided by the manufacturer.
- To prevent confusion, never store vehicle care products in empty food cans, bottles or other containers.
- Keep all care products out of reach of children.
- Harmful vapours may be produced when using vehicle care products. Therefore, care products should only be used in well-ventilated spaces or in the open air.
- Never use fuel, turpentine, engine oil, acetone or any other volatile liquid to wash, clean or care for the vehicle. These are toxic and highly flammable.



WARNING

Inappropriate care and cleaning of vehicle components may effect the vehicle safety equipment, increasing the risk of severe injury.

- Vehicle components should only be cleaned and maintained in accordance with the manufacturer's instructions.
- Only use approved or recommended care products.



CAUTION

- Cleaning products which contain solvents will damage the material.
- To avoid damage, stubborn stains should be removed by a specialised workshop.



Note

Suitable vehicle care products are available from your Technical Service. ■

Treating your upholstery

Check list

For information on how to treat and care for the vehicle upholstery, please bear the following in mind ⇒ ①:

- ✓ Before entering the vehicle, fasten all Velcro fastenings which could come into contact with upholstery and coverings. If the Velcro fastenings on upholstery and material covers are not securely fastened, this could damage them.
- ✓ To prevent damage, do not allow the upholstery or covers to come into contact with sharp or decorative objects. Decorative objects such as zips, rivets and rhinestones on clothing and belts.
- ✓ Dust and grit in the pores and seams should be removed regularly to prevent them scratching and damaging the surface.
- ✓ Always check that the dyes used in clothing are fast to prevent them from staining the upholstery. This is particularly true for clear-coloured upholstery.



CAUTION

Failure to observe the instructions in the check list for caring for your upholstery could result in damage or discolouration of the upholstery and covers.

- Always follow the check list and perform the necessary operations.



Note

SEAT recommends you take the vehicle to a Specialised workshop to treat any stains on the upholstery caused by the discolouration of clothing. ■

Padding and fabric trim cleaning

Normal cleaning

- Before applying cleaning products, please read the instructions for handling and the warnings shown on the container.
- The upholstery, textile covers, and carpet should be regularly vacuumed (with vacuum brush).
- We recommend that you use a soft sponge or lint-free, micro-fibre cloth for normal cleaning ⇒ ②.

General superficial dirt on upholstery and textile covers can be cleaned with a normal foam cleaning product.

If the upholstery and the material trims are very dirty, we recommend you have them cleaned by a specialist cleaning firm.

Cleaning stains

It may be necessary to clean the whole surface and not only the stain itself. Especially if the surface has been dirtied through normal use. Otherwise, the stained area may become lighter than the rest of the surface after treatment. ▶

Type of stain	Cleaning the vehicle
<i>Water-based stains</i> , e.g. coffee or fruit juice.	<ul style="list-style-type: none"> – Use a sponge and wipe with a solution of water and wool wash. – Dry with a dry, absorbent cloth.
<i>Persistent stains</i> , e.g. chocolate or make-up.	<ul style="list-style-type: none"> – Apply a washing paste^{a)} directly to the stain and allow it to work. – Apply clean water using a sponge or damp cloth to remove the cleaning product deposits. – Dry with a dry absorbent cloth.
<i>Grease-based stains</i> , e.g. oil or lipstick.	<ul style="list-style-type: none"> – Apply neutral soap or cleaning paste^{a)} and allow it to work. – Remove dissolved grease or colour particles with an absorbent cloth. – Then apply clean water. Take care not to soak the upholstery.

a) Bile soap can be used as a cleaning paste.

! CAUTION

Brushes should only be used to clean the mats and floor mat! Other surfaces may be damaged if a brush is used.

! CAUTION

Do not use steam cleaning equipment, as the dirt becomes more encrusted in the material when steam is applied.

! CAUTION

Never use brushes for cleaning damp material as they could damage the surface.

Cleaning storage compartments, drinks holders and ashtray



Fig. 118 In the front part of the centre console: Storage compartment with cup holder



Fig. 119 Ashtray removed and open with area to stub cigarettes

Cleaning storage compartments and drinks holders


- Use a clean, damp, lint-free cloth to clean parts.
- If this does not provide satisfactory results, we recommend using a special **solvent-free** plastic cleaning product.

Cleaning the ashtray

- Extract the ashtray and empty it.
- Clean the ashtray with a dishcloth.

Use a toothpick or similar to remove ash from the area where cigarettes are stubbed out ⇒ Fig. 119.

Care and cleaning of plastic parts, wooden trim and the dash panel

- Use a clean, damp, lint-free cloth to clean parts.
- *Clean plastic parts (inside and outside the vehicle) and the dash panel* with a special **solvent-free** product for the care and cleaning of plastic, approved by SEAT ⇒ .
- Wash *wooden trims* with a mild soap and water solution.
- *Clean the Portable Navigation System housing (Supplied by SEAT)* with a dry cloth only.

WARNING

Solvents cause the surfaces of the airbag modules to become porous. If an airbag is accidentally triggered, the detachment of plastic parts could cause serious injury.

- **Never clean the dash panel and the surfaces of the airbag modules with cleaners containing solvents.**


CAUTION

When cleaning the instrument panel, be careful not to dampen the Portable Navigation System connections as this can damage the electrical installation.

Cleaning seat belts

If the seat belt is very dirty, the belt retractor may not work correctly thus preventing the seat belt from operating correctly.

The seat belts should never be removed from the vehicle for cleaning.

- Use a soft brush to remove the worst dirt ⇒ .
- Pull the seat belt right out and leave it out.
- Clean dirty seat belts with a *gentle* soap and water solution.
- Wait until they are completely dry.
- Only allow the seat belt to retract when it is completely dry.

WARNING

Check the condition of all the seat belts at regular intervals. If the webbing or other parts of the seat belt are damaged, the vehicle should be taken to a Specialised workshop immediately and the belts should be replaced. It is extremely dangerous to drive using damaged seat belts and could result in serious injury or loss of life.

- **Seat belts and their components must never be cleaned with chemical products, nor should they be allowed to come into contact with corrosive liquids, solvents or sharp objects. This could affect the strength of the seat belt webbing.**

 **WARNING (Continued)**

- Seat belts should be completely dry before retracting. Damp could damage the belt retractor so that it does not operate correctly.
- Do not allow liquids or foreign bodies to enter the buckle fastenings. This could damage the buckles and seat belts.
- Never attempt to repair, modify or remove a seat belt yourself.
- Always have damaged seatbelts replaced immediately by seat belts approved for the vehicle in question by SEAT. Seat belts which have been worn in an accident and stretched must be replaced by a Specialised workshop. Renewal may be necessary even if there is no apparent damage. The belt anchor points should also be checked.

Wheels and tyres

Introduction

SEAT recommend that all work on tyres and wheels is carried out by a Specialised workshop. They have the necessary special tools and replacement parts, trained personnel and facilities for disposing of the old tyres. SEAT recommends visiting a Technical Service.

Additional information and warnings:

- Transporting ⇒ page 97
- Braking, stopping and parking ⇒ page 134
- Caring for and cleaning the vehicle exterior ⇒ page 197
- Notes for the user ⇒ page 233
- Vehicle tool kit ⇒ page 246
- Wheel trims ⇒ page 248
- Change wheel ⇒ page 250
- Tire Mobility Set ⇒ page 256



WARNING

The vehicle cannot be totally controlled or braked if the tyres (new or used) are worn or damaged.

- Incorrect use of wheels and tyres could make driving more dangerous and result in serious accidents and damage.
- All four wheels must be fitted with radial tyres of the same type, size (rolling circumference) and the same tread pattern.
- New tyres do not give maximum grip and will not have reached their maximum braking capacity to start with, and therefore need running in. To prevent accidents and major damage, extreme caution should be taken for the first 600 km (400 miles).



WARNING (Continued)

- Check tyre pressures regularly and ensure they are maintained at the pressures indicated. If the tyre pressure is too low, the tyres could over-heat, resulting in tread detachment or even burst tyres.
- Never drive on damaged (punctured, cut, cracked or dented) or worn tyres. Driving on damaged or worn tyres could result in burst tyres, serious accidents or damage. Worn or damaged tyres must be replaced immediately.
- Never exceed the maximum permitted speed or loads specified for the type of tyre fitted on your vehicle.
- The efficiency of driver and brake assist systems also depends on the grip of the tyres.
- If you notice unusual vibration or if the vehicle pulls to one side when driving, stop the vehicle immediately and check the tyres and wheels for damage.
- To minimise the risk of losing control of the vehicle or causing a serious accident, never undo the bolted joints of beadlock wheels.
- Never mount used tyres or wheels if you are not sure of their previous history. They may be damaged, although the damage is not immediately visible.
- Old tyres, even if they have never been used, may lose air or burst unexpectedly while driving, especially at high speeds, resulting in serious accident and injury. If tyres are over six years old, they should only be used in an emergency and with extreme caution.



Note

For technical reasons, it is not generally possible to use the wheels from other vehicles. In some cases, this may also be true for the same model of wheel. Please refer to the vehicle documents or ask at a Technical Service. ■

About your tyres and wheels

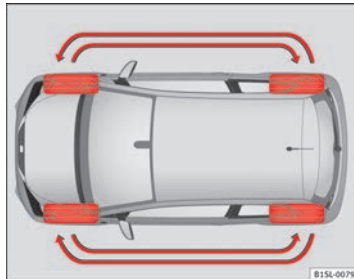


Fig. 120 Diagram for changing wheels

The tyres of a vehicle are the components which are subjected to most stress and are the most underestimated. Tyres are very important, as the support offered by their narrow surface is the only point of contact between the vehicle and the road.

The service life of tyres is dependent on tyre pressure, driving style, the care they receive and the correct fitting.

The tyres and wheel rims are an essential part of the vehicle's design. The tyres and rims approved by SEAT are specially matched to the characteristics of the vehicle and our critical to good road holding and safe handling.

Avoiding damage to tyres and wheels

- If you have to drive over a kerb or similar obstacle, drive very slowly and as near as possible at a right angle to the kerb.
- Inspect the tyres regularly for damage (punctures, cuts, cracks, dents).
- Remove any foreign bodies found on the outside of the tread provided they have not passed through the wall of the tyre ⇒ page 216.
- The instructions for tyre control systems should always be observed.

- Replace damaged or worn tyres as soon as possible ⇒ page 216.
- Regularly check tyres for non-visible damage ⇒ page 216.
- Never exceed the maximum permitted speed or loads specified for the type of tyre fitted on your vehicle ⇒ page 218.
- Do not allow tyres (including the spare wheel) to come into contact with aggressive substances, grease, oil, fuel or brake fluid ⇒ ⚠.
- Lost valve caps should be replaced immediately.

Tyres with directional tread pattern

Tyres with directional tread pattern have been designed to operate best when rotating in only one direction. An arrow on the tyre sidewall indicates the direction of rotation on tyres with directional tread ⇒ page 218. Always observe the direction of rotation indicated when mounting the wheel. This guarantees optimum grip and helps to avoid aquaplaning, excessive noise and wear.

If the tyre is mounted in the opposite direction of rotation, drive with extreme caution, as the tyre is no longer being used correctly. This is of particular importance when the road surface is wet. Change the tyre as soon as possible or remount it with the correct direction of rotation.

Interchanging tyres


To ensure that the wear is equal on all tyres the wheels should be changed round from time to time according to the system ⇒ Fig. 120. All the tyres will then last for about the same time.

SEAT recommends you take the vehicle to a Specialised workshop to have the tyres changed.

Tyres that are over 6 years old

Tyres are subject to an ageing process as a result of physical and chemical processes. This may affect their performance. Tyres which are stored for long periods of time without being used, harden and become more fragile than tyres which are in constant use.

SEAT recommends that tyres over six years old are replaced with new tyres. This also applies to tyres (including the spare wheel) which appear to be in ▶

perfect condition on the outside and which have a tread depth within the values stipulated by the Law ⇒ .

The date of manufacture, part of the tyre identification number (TIN), indicates the age of the tyre (TIN) ⇒ page 218.

Storing tyres

Mark tyres when you remove them to indicate the direction of rotation (left, right, forwards, backwards). This ensures you will be able to mount them correctly when you replace them. When removed, the wheels and/or tyres should be stored in a cool, dry and preferably dark location. Do **not** place tyres mounted on the wheel in a vertical position.

Protect tyres not mounted on wheels from dirt by storing them in suitable bags and standing them on the ground on their tread.



WARNING

Aggressive fluids or substances could result in visible or invisible damage with the consequent risks.

- Always ensure that tyres do not come into contact with chemical products, oil, grease, fuel, brake fluid or other aggressive substances.



WARNING

Old tyres, even if they have never been used, may lose air or burst unexpectedly while driving, resulting in serious accident or damage.

- If tyres are over six years old, they should only be used in an emergency and with extreme caution.



For the sake of the environment

Old tyres must be disposed of by qualified personnel according to the laws in the country concerned. ■

Wheel rims

The design of wheel bolts is matched to the rims. If different rims are fitted, the correct wheel bolts with the right length and correctly shaped bolt heads must be used. This ensures that wheels are fitted securely and that the brake system functions correctly ⇒ page 250.


For technical reasons, it is not generally possible to use the wheels from other vehicles. In some cases, this may also be true for the same model of wheel.

The tyres and rims approved by SEAT are specially matched to the characteristics of the vehicle and are critical to good road holding and safe handling.


Wheel bolts

Wheel bolts must be tightened to the correct torque ⇒ page 250.

Beadlock wheel rims

Beadlock wheel rims have various components. These are joined together by special bolts using a special procedure. This ensures good performance, a better seal, improved safety and wheel run out. Therefore, worn rims should always be replaced and must only be repaired in a Specialised workshop. SEAT recommends visiting a Technical Service ⇒ .

Wheel trims with bolted trims

Wheel trims may be fitted with interchangeable trim parts which are attached to the rim using self-locking bolts. Worn trims should only be replaced at a Specialised workshop. SEAT recommends visiting a Technical Service ⇒  ▶

⚠ WARNING

The use of worn or damaged wheel trims could make driving more dangerous and result in serious accidents and damage.

- Only wheel trims which have been approved for use with your vehicle should be used.
- Inspect wheel trims regularly for damage and replace as required.

⚠ WARNING

If the bolted joints of wheel trims with bolted ring trims are not correctly tightened or loosened, this could result in serious accident.

- Never loosen the bolted joints of wheel trims with bolted ring trims.
- Any work relating to wheel trims with bolted trims should be carried out at Specialised workshop. SEAT recommends visiting a Technical Service.

Replacement of new tyres and wheel trims

New tyres

- When tyres are new, drive with extreme caution for the first 600 km (400 miles), as all tyres need to be *run-in*. Tyres which have not been run-in do not have such good grip ⇒ ⚠ or braking capacity ⇒ ⚠.
- All four wheels must be fitted with radial tyres of the same type, size (rolling circumference) and the same tread pattern.
- The tread depth of new tyres may vary, according to the type and make of tyre and the tread pattern.

Replacing tyres

- Where possible, always replace both wheels on an axle (both wheels on the front axle or both wheels on the rear axle) ⇒ ⚠.
- Only replace used tyres with those authorised by SEAT for the corresponding type vehicle. Pay special attention to size, diameter, and maximum load and speed capacity.
- Never use tyres which are larger than SEAT approved tyres. If the tyres are too big, they may knock or rub against the chassis or other components, resulting in damage.

⚠ WARNING

New tyres do not give maximum grip and will not have reached their maximum braking capacity to start with, and therefore need running in.

- To prevent accidents and major damage, extreme caution should be taken for the first 600 km (400 miles).

⚠ WARNING

There should be adequate space between the tyres and the vehicle in accordance with the vehicle design. If this is not the case, the tyres may rub against parts of the running gear, chassis or brake lines, leading to faults in the brake system or to tread detachment, and the risk of burst tyres.

- The true tyre dimension should not be greater than the dimensions of tyres manufactured and approved by SEAT and should not rub against parts of the vehicle.

i Note

Although tyres may be shown as being the same size, the true dimensions of different types of tyre may vary with respect to the nominal size, or tread patterns may be different. ▶

**Note**

If you use tyres that are approved by SEAT, you can be sure that the true tyre dimensions will be correct for your vehicle. For other tyre models, the tyre vendor should provide the manufacturer's certificate with the tyre, indicating that this type of tyre is suitable for your vehicle. This certificate should always be carried with the vehicle. ■

Tyre pressures

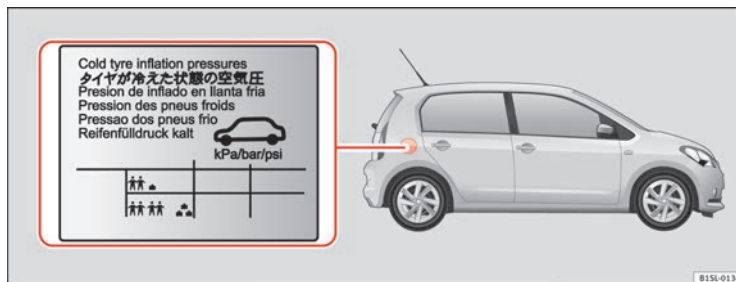


Fig. 121 Position of tyre pressure specification plate

The correct tyre pressures for tyres fitted at the factory is shown on a label and is valid for summer and winter tyres. This label ⇒ Fig. 121 is either in the driver door strut or inside the fuel cap.

Under-inflation or over-inflation will reduce the life of the tyres considerably and also impair the vehicle's handling ⇒ Δ. It is essential to maintain the correct tyre pressures, especially if driving at **high speeds**. Incorrect tyre pressure causes premature wear and could cause tyre blow-out.

The pressure should therefore be checked at least once a month and before starting a journey.

As a general rule, the pressures given are for **cold tyres**. When the tyres are hot, the pressures are greater.

Never deflate a hot tyre in order to obtain the required pressure. This could result in very low tyre pressures which may lead to sudden blow-outs. ►

Checking tyre pressures

Check tyre pressures only when the vehicle has not been driven for more than a few kilometres at low speeds in the past three hours.

- Check tyre pressures regularly, and only when the tyres are cold. Always check all tyres, including the spare wheel. Check tyre pressures more often in colder regions, and only when the vehicle has not been driven recently. Always use a correctly-operating tyre gauge.
- Adjust tyre pressures to the loads carried in the vehicle.
- After adjusting the tyre pressure, check that the caps are properly screwed.

The **spare wheel** or **temporary spare wheel** must be at the maximum pressure specified.

WARNING

If tyre pressures are too high or too low, the tyre may deflate or burst suddenly while driving. This could result in serious accident.

- If the tyre pressure is too low, the tyres could overheat, resulting in tread detachment or even burst tyres.
- When driving at high speeds and/or fully loaded, the tyre could suddenly overheat, burst or be subject to tread detachment, with the resultant loss of control of the vehicle.
- Tyre pressures which are too high or too low reduce the service life of the tyre, affecting the vehicle's performance.
- Tyre pressures should be checked regularly, at least once a month and before long journeys.
- Adjust the pressures of all the tyres to the vehicle load.
- Never deflate excess pressure from hot tyres.

CAUTION

- Take care not to tilt the manometer when placing it on the valve. Otherwise, the valve may be damaged.
- To avoid damage to the valves, always replace valve caps correctly. Check that the caps are identical to the standard caps and have been correctly tightened.

For the sake of the environment

Under-inflated tyres will increase the fuel consumption. ■

Tread depth and wear indicators

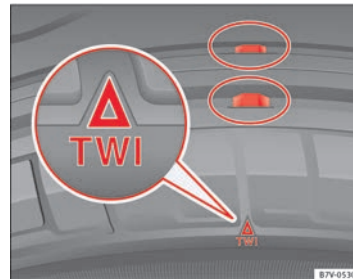



Fig. 122 Tyre tread: tread wear indicators

Tread depth

Certain driving conditions require a deeper tread, as well as needing the tread to be approximately the same on the front and rear tyres. This is particularly important when driving in winter, in cold temperatures and on wet roads ⇒ . ▶

Vehicle diagram

Prior to a journey...

While driving

Care, cleaning and maintenance

If and when

Technical Data

The minimum tread depth required by law in the majority of cases is 1.6 mm, measured in the tread grooves next to the tread wear indicators. Observe legal requirements in each country.

The performance of **winter tyres** is much reduced when the tread has worn to 4 mm (5/32 inch).

The tread depth of new tyres may vary, according to the type and make of tyre and the tread pattern.

Wear indicators on the tyre

The original tyres on your vehicle have 1.6 mm high ⇒ Fig. 122 tread wear indicators running across the tread. A number of these indicators are equally spaced around the tyre tread. Certain marks on the tyre walls (for example, the letters "TWI" or other symbols) indicate the position of the wear indicators.

Tread wear indicators indicate if a tyre is worn. Tyres must always be replaced before the tyre tread has worn to the level of the indicator.




WARNING

Driving with worn tyres is dangerous, and may lead to loss of control of the vehicle with serious consequences.

- Tyres must be replaced before the wear indicators are at the same level as the tread pattern.
- Worn tyres have significantly reduced grip, especially on wet surfaces, increasing the risk of "aquaplaning".
- Worn tyres make control of the vehicle more difficult in normal or difficult driving conditions, increasing the braking distance and the risk of skidding.

Damaged tyres

Damage to wheels and tyres is often not immediately visible. If you notice unusual **vibration** or the vehicle **pulling to one side**, this may indicate that one of the tyres is damaged ⇒ .

- Slow down immediately if you think you have a damaged wheel.
- Check the wheels and tyres for damage.
- If tyres are worn, stop driving and seek qualified assistance.
- If there is no visible exterior damage, drive slowly and carefully to the nearest Specialised workshop and have the vehicle checked.

Foreign bodies in the tyre

- Do not remove foreign bodies if they have penetrated through the tyre wall!
- You should obtain professional assistance immediately.

Wear of tyres

The wear of tyres depends on a number of factors, for example:

- Driving style.
- Unbalanced wheels.
- Running gear settings.

Driving style: driving round bends fast or sudden acceleration or braking speed up the wear of tyres. When the driving style is normal, if the tyres wear too quickly, have the running gear settings checked at a Specialised workshop.

Wheel run-out: The wheels on new vehicles are balanced. However, certain circumstances may lead to imbalance (run-out), which is detected as vibrations in the steering wheel. Run-out leads to wear of the steering and suspension. In the event of run out, the wheels should be balanced again. When a new wheel is fitted, it should be balanced again. ▶

Running gear settings: an incorrectly positioned running gear increases the wear of tyres and affects your safety while driving. If tyres wear too quickly, have the wheel alignment checked at a Specialised workshop.

WARNING

If you notice unusual vibration or the vehicle pulls to one side while driving, this may indicate that one of the tyres is damaged.

- Reduce speed immediately and stop, while observing the highway code.
- Check the wheels and tyres for damage.
- Never carry on driving on worn tyres or wheels. Request qualified assistance immediately.
- If there is no visible exterior damage, drive slowly and carefully to the nearest Specialised workshop and have the vehicle checked.

Spare wheel or temporary spare wheel*



Fig. 123 In the luggage compartment: hand controlled wheel for securing the spare wheel


Removing the spare wheel

- Open the rear lid and lift the luggage compartment shelf ⇒ page 100.
- If necessary, remove the luggage compartment variable floor ⇒ page 100.
- Lift up the carpet from the recess and remove it from the luggage compartment.
- If necessary, take out the vehicle tool kit with the container.
- Completely remove the hand controlled wheel from the centre of the spare wheel ⇒ Fig. 123 by turning it in an anticlockwise direction, and take out the spare wheel.

Storing the replaced wheel

- Pull back the carpet.
- With the wheel rim facing downwards, situate the replaced wheel in the spare wheel well so that the wheel rim central hole coincides with the opening.
- Turn the hand controlled wheel with the shank screwed clockwise until the replaced wheel is secured.
- If necessary, store the vehicle tool in the container, inside the luggage compartment.
- Replace the carpet on the luggage compartment floor.
- Lower the rear shelf.
- Close the rear lid.

If the spare wheel is different to the rest of the vehicle tyres

If the spare tyre is not the same as the tyres that are mounted on the vehicle - for example with winter tyres or the temporary spare wheel - you should only use the spare tyre for a short period of time and drive with extra care ⇒ .

Refit the normal road wheel as soon as possible.

Please observe driving advice: 

- Do not drive faster than 80 km/h (50 mph).
- Avoid heavy acceleration, hard braking and fast cornering.
- Snow chains on the temporary spare wheel are not permitted ⇒ page 220.
- After mounting the spare wheel or the temporary spare wheel, check the tyre pressure as soon as possible ⇒ page 214.

It is advisable to check the spare wheel or temporary spare wheel tyre pressure when checking the rest of the vehicle wheels at least once a month. The spare wheel should have the highest pressure allowed for the vehicle ⇒ page 214. The sticker situated on the temporary spare wheel shows the tyre pressure.

WARNING

Incorrect handling of the spare wheel or the temporary spare wheel can cause loss of vehicle control, producing collisions or other serious accidents and injury.

- Never use the spare wheel or the temporary spare wheel if it is damaged or worn to the wear indicator.
- In some vehicles the spare wheel is smaller than the original tyres. This can be seen on a sticker showing the text “80 km/h” and “50 mph”. This text indicates the maximum velocity permitted for this type of tyre.
- Never drive faster than 80 km/h (50 mph). Avoid powerful acceleration, hard braking and taking corners at high speed.
- Never drive more than 200 km (120 miles) with a temporary spare wheel fitted to the drive axle.
- Replace the temporary spare wheel for a normal wheel as soon as possible. The compact temporary spare wheel is only intended for temporary use over short distances.
- The temporary spare wheel must always be secured with the factory supplied wheel bolts.

WARNING (Continued)

- You should never use more than one temporary spare wheel.
- After mounting the temporary spare wheel, check the tyre pressure as soon as possible ⇒ page 214.
- Snow chains on the temporary spare wheel are not permitted.



Note

Wherever possible, secure the spare wheel, temporary spare wheel or the replaced wheel safely in the luggage compartment. In vehicles with anti-puncture kit, it is **not** possible to secure the defective wheel. ■

Tyre code

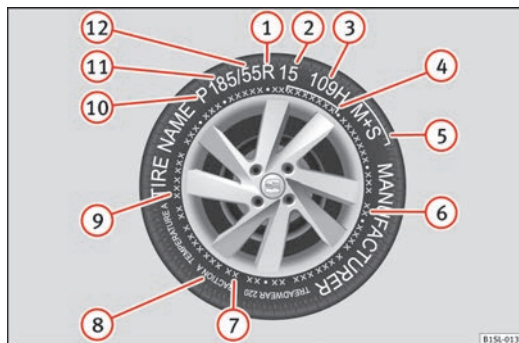



Fig. 124 Universal code on tyres

- ① Radial
- ② Rim diameter code
- ③ Load index & speed rating
- ④ DOT tyre identification number
- ⑤ Severe snow conditions
- ⑥ Tyre ply composition and materials used
- ⑦ Max. load rating
- ⑧ Treadwear, traction and temperature grades
- ⑨ Max. permissible inflation pressure
- ⑩ Passenger vehicle tyre
- ⑪ Nominal width of tyre in millimetres
- ⑫ Ratio of height to width (aspect ratio)

Tyre code (example)	Meaning
<i>Make, logotype</i>	<i>Manufacturer</i>
<i>Product name</i>	Name of tyre assigned by manufacturer.
P255 / 55 R 18	Size:
	P Passenger vehicle code.
	255 Nominal width between walls, in mm.
	55 Height/width ratio in %
	R Tyre type (R indicates "radial").
18 Rim diameter in inches	
109 H	Load index → page 220 and speed rating → page 220.
XL	("Reinforced") tyres.
M+S or M/S or 	Winter tyres code (mud and snow tyres).
RADIAL TUBELESS	Radial tyre without inner tube.
E4 ...	E-mark certifying tyre complies with international legislation followed by a number denoting the country granting the authorisation. The authorisation number (several digits) is shown below.

Tyre code (example)	Meaning
DOT BT RA TY5 1709	Tyre identification number (TIN ^a), may be only on interior wall of wheel) and date of manufacture:
	DOT The tyre complies with the legal requirements of the US Department of Transport, responsible for tyre safety regulations.
	BT Place of manufacture code.
	RA Information about manufacturer and tyre size.
	TY5 Manufacturer's tyre specifications.
1709	Date of manufacture: Week 17 of 2009.
TWI	This identifies the position of the Tread Wear Indicator → page 215.
Made in Germany	Country of manufacture.
MAX LOAD 615 KG	US load rating, indicating maximum permitted load per tyre.
MAX INFLATION 350 KPA (51 PSI)	US limit, indicating maximum permitted tyre pressure.
SIDEWALL 1 PLY RAYON	Information about tyre wall components: 1 layer of rayon (artificial silk).
TREAD 4 PLIES 1 RAYON + 2 STEEL + 1 NYLON	Information about tread components: In the example, there are 4 layers below the tread: 1 layer of rayon (artificial silk), 2 layers of steel reinforcement and 1 layer of nylon.
Information for the end consumer concerning the comparative values of the established base tyres (standardised test procedures) → page 233:	
TREADWEAR 220	Relative service life of the tyre, with respect to specific US standard test.
TRACTION A	Braking capacity of tyre on wet surface (AA, A, B or C).

Tyre code (example)	Meaning
TEMPERATURE A	Tyre temperature resistance at higher test speeds (A, B or C).
If the tyre has other markings, these are specific tyre manufacturer codes or specific national codes, e.g. for Brazil or China.	

^{a)} The letters TIN refer to the tyre serial number.

Tyres with directional tread pattern

Tyres with directional tread pattern have been designed to operate best when rotating in only one direction. An arrow on the tyre sidewall indicates the direction of rotation on tyres with directional tread. Always observe the direction of rotation indicated when mounting the wheel. This guarantees optimum grip and helps to avoid aquaplaning, excessive noise and wear.

If the tyre is mounted in the opposite direction of rotation, drive with extreme caution, as the tyre is no longer being used correctly. This is of particular importance when the road surface is wet. Change the tyre as soon as possible or remount it with the correct direction of rotation.

Tyre load rating

The load rating code indicates the maximum load in kilograms each wheel can carry (load capacity).

78	425 kg
81	462 kg
83	487 kg
85	515 kg
87	545 kg
91	615 kg

Speed rating

The speed rating indicates the maximum speed permitted for the tyres.

P	max. 150 km/h (93 mph)
Q	max. 160 km/h (99 mph)

R	max. 170 km/h (106 mph)
S	max. 180 km/h (112 mph)
T	max. 190 km/h (118 mph)
U	max. 200 km/h (124 mph)
H	max. 210 km/h (130 mph)
V	max. 240 km/h (149 mph)
Z	max. 240 km/h (149 mph)
W	max. 270 km/h (168 mph)
Y	max. 300 km/h (186 mph)

Some manufacturers use the letters “ZR” for tyres with a maximum authorised speed above 240 km/h (149 mph). ■

Snow chains

When using snow chains, applicable local legislation and maximum permitted speed limits must be observed.

In winter weather, snow chains not only help to improve grip but also improve the braking capacity.

The fitting of chains is permitted **only on front wheels** and **only with the following combinations of wheel trims and tyres**:

Tyre size	Wheel rim
165/70 R14	5 J x 14 offset of 35

SEAT recommends you ask a Technical Service for further information on wheel, tyre and chain sizes.

Wherever possible use fine-link chains measuring less than 15 mm including the lock. ▶

Remove wheel hub covers and trim rings before fitting snow chains ⇒ ①.
The wheel bolts should be covered with caps for safety reasons. These are available from Technical Services.

Temporary spare wheel

For technical reasons, snow chains must not be used on the compact temporary spare wheel ⇒ page 217.

If it is necessary to fit chains with the temporary spare wheel in use, install the temporary spare wheel on the rear axle in the event of a fault in a front wheel. Then, fit the rear wheel that is free, instead of the damaged front wheel. In this situation, observe the rotating direction of the wheels. SEAT recommends attaching the snow chains before fitting the wheel.

WARNING

The use of unsuitable or incorrectly fitted chains could lead to serious accidents and damage.

- Always the appropriate snow chains.
- Observe the fitting instructions provided by the snow chain manufacturer.
- Never exceed the maximum permitted speeds when driving with snow chains.

CAUTION

- You must remove the snow chains to drive on roads which are free of snow. Otherwise they will impair handling, damage the tyres and wear out very quickly.
- Wheel trims may be damaged or scratched if the chains come into direct contact with them. SEAT recommends the use of covered snow chains.

Note

Snow chains are available in different sizes according to the vehicle type. ■

Accessories, replacements, repairs and modifications

Introduction

Additional information and warnings:

- Seat belts ⇒ page 57
- Airbag system ⇒ page 67
- Roof carrier ⇒ page 104
- Ashtray and cigarette lighter ⇒ page 115
- Power socket ⇒ page 117
- Braking, stopping and parking ⇒ page 134
- Parking distance warning system ⇒ page 149
- Cruise control system (CCS) ⇒ page 152
- Working in the engine compartment ⇒ page 180
- Engine oil ⇒ page 185
- Engine coolant ⇒ page 189
- Vehicle battery ⇒ page 193
- Caring for and cleaning the vehicle exterior ⇒ page 197
- Care and cleaning of the vehicle interior ⇒ page 205
- Notes for the user ⇒ page 233
- ⇒ Booklet Radio system
- Instruction Manual for the Portable Navigation System (supplied by SEAT) in the equipment.



WARNING

The use of unsuitable spare parts and accessories, or incorrectly performed modifications or repairs may result in damage to the vehicle, accidents and serious injury.

- SEAT strongly recommends you to only use SEAT approved accessories and SEAT® original spare parts. These parts and accessories have been specially tested by SEAT for suitability, reliability and safety.
- Have any repairs or modifications carried out at a Specialised workshop. Specialised workshops have the necessary tools, diagnostics equipment, repair information and qualified personnel.
- Only mount parts with the same specifications as the parts fitted at factory.
- Never mount, fasten or fit objects such as drink holders or telephone cradles over the covers of the airbag modules or within their deployment zones.
- Only use wheels and tyre combinations which have been approved by SEAT for your vehicle type.

Running-in

Please observe the instructions for running-in new components.

Running-in the engine

The engine needs to be run in over the first 1500 km (1000 miles). During its first few hours of running, the internal friction in the engine is greater than later on when all the moving parts have bedded down.

How the vehicle is driven for the first 1500 km (1000 miles) influences the future engine performance. Throughout the life of the vehicle, it should be driven at a moderate speed, especially when the engine is cold, as this will reduce engine wear and increase its useful life. Never drive at extremely low engine speeds. Change down to a lower gear when the engine no longer runs "smoothly". **Up to 1000 kilometres the following instructions apply:**

- Do not use full throttle.
- Do not force the engine above two thirds of its maximum speed.

Between 1000 and 1500 kilometres (600 to 1000 miles), gradually increase power until reaching the maximum speed and high engine speeds.

Running in new tyres and brake pads

- Replacement of new tyres and wheel trims → page 210
- Notes on the brakes → page 134



For the sake of the environment

If the engine is run in gently, the life of the engine will be increased and the engine oil consumption reduced.

Accessories and spare parts

SEAT recommends you consult an Official Service before purchasing accessories and spare parts or consumables. For example, when fitting accesso-

ries at a later date, or when replacing a component. A SEAT Official Service will advise you as to the legal requirements and manufacturer's recommendations regarding accessories, spare parts and other components.

SEAT recommend you use only approved **SEAT accessories** and **genuine SEAT spare parts**®. These parts and accessories have been specially tested by SEAT for suitability, reliability and safety. In addition the SEAT Technical Service will guarantee that the assembly is carried out professionally.

Although we continually monitor the market, SEAT cannot guarantee that products **not approved by SEAT** are reliable, safe and suitable for the vehicle. Therefore, SEAT cannot accept liability, even in those cases authorised by an officially recognised technical inspection office or other official body.

Any **retro-fitted equipment** which has a direct effect on vehicle control must be approved by SEAT for use in your vehicle and bear the e mark (the European Union's authorisation symbol). This includes cruise control systems or electronically controlled suspension.

If any **additional electrical components** are fitted which do not serve to control the vehicle itself, these must bear the CE mark (European Union manufacturer conformity declaration). This includes refrigerator boxes, laptops or ventilator fans.



WARNING

Unprofessional repairs or modifications to the vehicle may affect the performance of the airbags, resulting in operating faults or fatal accident.

- **Never mount, fasten or fit objects such as drink holders or telephone cradles over or next to the covers of the airbag modules or within their deployment zones.**
- **Objects placed over the airbag covers, or within their deployment zones, could lead to serious injury or loss of life if the airbags are triggered.**

Fluids and consumables

All vehicle fluids and consumables, such as notched belts, tyres, coolant fluids, engine oils, spark plugs and batteries are continually being developed. Therefore all fluids and consumables should be changed at a Specialised workshop. Technical Services are permanently informed of any modifications.



WARNING

The incorrect use or handling of fluids or consumables may result in accident, serious injury, burns or intoxication.

- Therefore, fluids must always be stored closed in their original container.
- Never store fluids in empty food containers or bottles as other people may accidentally drink the fluid.
- Keep all fluids and consumables out of reach of children.
- Read and observe the information and warnings given on the fluid containers.
- Only work in the open air or in well-ventilated zones, when using products which give off harmful vapours.
- Never use fuel, turpentine, engine oil, acetone or any other volatile liquid in the maintenance of the vehicle. These are toxic and highly flammable. They could lead to fire or explosions!



CAUTION

- Only use appropriate fluids. Never mix the fluids. Using the wrong fluids could cause serious malfunctions and engine damage!
- Accessories and other components mounted in front of the air inlet reduce the cooling effect of the coolant. If the engine is running under great strain in high outside temperatures, it could overheat.



For the sake of the environment

Leaking fluids could pollute the environment. Collect any spilt fluids in suitable containers and dispose of in accordance with legislation and with respect for the environment. ■

Repairs and technical changes

When performing repairs and technical modifications, SEAT's directives must be observed! ⇒ ⚠

Unauthorised modifications to the electronic components or software in the vehicle may cause malfunctions. Due to the way the electronic components are linked together in networks, other indirect systems may be affected by the faults. This may significantly affect the vehicle's performance, increase component wear and could mean that the vehicle registration documents are no longer valid.

Your SEAT Official Service cannot be held liable for any damage caused by technical modifications or repairs performed incorrectly.

The SEAT Official Service does not accept liability for damage resulting from technical modifications or repairs performed incorrectly; neither is the SEAT warranty valid in these cases.

SEAT recommends you have any technical modifications or repairs performed at a SEAT Official Service and that you use **genuine SEAT spare parts**®.

Vehicles with special accessories and equipment

The manufacturers of additional equipment guarantee that the equipment complies with applicable laws and regulations with respect to the environment, in particular Directives 2000/53/CE and 2003/11/CE. The first directive governs the disposal of end-of-life vehicles while the second refers to the restrictions on the marketing and use of certain dangerous substances and preparations. ▶

The vehicle owner should keep the documentation for the additional equipment safely and hand it over to the scrap yard at the end of the vehicle's service life. This ensures that any additional equipment mounted in end-of-life vehicles is correctly disposed of with respect for the environment.

WARNING

Repairs or modifications which are not performed correctly may result in damage or errors in the vehicle operation, affecting the efficiency of the driver assist systems. This could result in serious accident.

- All repairs and modifications to the vehicle should only be performed by a Specialised workshop.

Repair and faults in the airbag system

When performing repairs and technical modifications, SEAT's directives must be observed! ⇒ ⚠

Modifications and repairs to the front bumper, doors, front seats, and repairs to the roof or chassis should only be carried out in a Specialised workshop. These components may contain parts or sensors belonging to the airbag system.

If work is carried out on the airbag system or parts have to be removed and fitted on the system when performing other repair work, parts of the airbag system may be damaged. The consequence may be that, in the event of an accident, the airbag inflates incorrectly or does not inflate at all.

So that the effectiveness of the airbag is not reduced and that removed parts do not cause any injuries or environmental pollution, regulations must be observed. These requirements are known to qualified dealerships.

Modifications to the vehicle suspension may affect the operation of the airbag system in the event of collision. For example, if wheel and tyre combinations not approved by SEAT are used, or if the vehicle height is lowered,

the suspension is stiffened or the suspension springs, telescopic arms, dampers, etc., are modified, the results received by the airbag sensors and sent to the control unit may not be accurate. For example, some modifications to the suspension could increase the force measured by the sensors and result in the triggering of the airbag systems in collisions. Under normal conditions, the measured values would be lower and the airbag would not have been triggered. Other modifications may reduce the forces measured by the sensors and therefore the airbags are not triggered in situations when they should have triggered.

WARNING

Repairs or modifications which are not performed correctly may result in damage or errors in the vehicle operation, affecting the efficiency of the airbag systems. This could result in serious or fatal accident.

- All repairs and modifications to the vehicle should only be performed by a Specialised workshop.
- Airbag modules must never be repaired: if damaged, they must be replaced.
- Never fit recycled or reused airbag components in your vehicle.

WARNING

Modifications to the vehicle suspension, including the use of unauthorised wheel and tyre combinations, may affect the performance of the airbags and increase the risk of serious or fatal injury in the event of accident.

- Never fit suspension components which are not identical to the original parts mounted in the vehicle.
- Never use wheel and tyre combinations not approved by SEAT.

Retro-fitting of two-way radios

An exterior aerial is required for the use of two-way radios in the vehicle.

The retro-fitting of electrical or electronic appliances in the vehicle is subject to their approval for use in your vehicle. Under certain circumstances, this could mean that your vehicle registration documents are no longer valid.

SEAT has approved your vehicle for use with two-way radios providing the following conditions are observed:

- The exterior aerial must be mounted professionally.
- The maximum transmitting power is 10 watts.

An only external aerial is needed to give the equipment its optimal reach.

Check first with a Specialised workshop if you wish to use a two-way radio with a transmitting power of over 10 watts. The Specialised workshops are familiar with the technical options for installation. SEAT recommends visiting a Technical Service.

All legal requirements, together with the instructions for the use of two-way radios must be observed.

WARNING

If the two-way radio is not securely fastened in position, it could be sent flying around the vehicle in the event of sharp braking, sudden manoeuvres or accident, causing injury.

- **While driving, two-way radios must be securely fastened in position, outside the airbags deployment zones, or safely stowed away.**

WARNING

When using a two-way radio without a connection to an exterior aerial, the maximum permitted levels of electromagnetic radiation may be exceeded. This is also the case if the aerial has not been correctly installed.

- **You should only use a two-way radio inside the vehicle if it has first been correctly connected to an exterior aerial.**

Information stored by the control units

Your vehicle is fitted at the factory with a series of electronic control units responsible for the engine and gearbox management. In addition, the control units supervise the performance of the exhaust gas system and the air-bag systems.

Therefore, while the vehicle is being driven, these electronic control units are continuously analysing the vehicle data. In the event of faults or deviations from the theoretical values, only this data is stored. Normally, the warning lamps on the instrument panel light up in the event of faults.

This data can only be read and analysed using special equipment.

The storing of the data allows specialised workshops to detect and repair faults. Stored data may include:

- Data relating to the engine or the gearbox
- Speed
- Direction of travel
- Braking force
- Detection of seat belt

The vehicle control units never record conversations held by passengers in the vehicle.

In vehicles equipped with an emergency call function via the mobile telephone or other appliances connected in the vehicle, it is possible to send the vehicle position. If the control unit records an accident with airbag activation, the system may automatically send a signal. This will depend on the network operator. Normally, transmission is only possible in areas with good coverage.

Event Data Recorder

The vehicle is **not** fitted with an event data recorder.

An event data recorder temporarily stores the vehicle information. Therefore, in the event of accident, it is possible to obtain detailed information about how the accident occurred. For example, in vehicles with airbag systems, data relating to speed of impact, seat belt status, seat positions and airbag activation times may be stored. The volume of data depends on the manufacturer.

Event data recorders can only be mounted with authorisation from the vehicle owner and, in some countries, they are governed by local legislation.

Reprogramming control units

On the whole, all the data required for the component management is stored in the control units. The programming of certain convenience functions, such as the convenience indicators, individual door opening and instructions on the display can be modified using special equipment at the workshop. If the comfort functions are reprogrammed, the information and Instruction Manual descriptions will not coincide with the modified functions. Therefore, SEAT recommends that any modifications are recorded in the section "Other workshop notes" in the Maintenance Programme.

The SEAT Official Service must have a record of any modification to the programming.

Reading the vehicle fault memory

There is a diagnostics connector in the vehicle interior for reading the vehicle fault memory. The fault memory documents errors and deviations from the theoretical values of the electronic control units.

The diagnostics connector is in the driver side footwell area, next to the lever for opening the bonnet, below a cover.

The fault memory should only be read and reset by a Specialised workshop. ■

Using a mobile telephone in a vehicle without connection to an exterior aerial

Mobile telephones transmit and receive radio waves also called high-frequency energy, both when in use and when on stand-by. Scientific studies state that radio waves exceeding certain values may be harmful to the human body. International committees and authorities have established limits and directives in order to ensure electromagnetic radiation from mobile phones remains within certain limits that do not endanger human health. However, there is no available conclusive scientific evidence that cordless phones are completely safe.

That is why some experts recommend moderate use of the mobile telephone, and the appliance of measures to reduce radiation on the human body.

When a mobile telephone not connected to an exterior aerial is used inside the vehicle, the electromagnetic radiation may be greater than if the mobile phone were connected to a built-in aerial or to another exterior aerial.

If the vehicle is fitted with a suitable hands-free device that allows the employment of numerous additional mobile telephone functions with compatible Bluetooth technology[®], it will comply with the legislation in many countries which only permits the use of mobile phones inside vehicles using a hands-free device.

The hands-free system of the Portable Navigation System (supplied by SEAT) has been designed for use with conventional mobile phones and phones with Bluetooth technology[®] ⇒ page 229. Mobile telephones must be placed in a suitable telephone support or stored safely in the vehicle. If a support is used for the telephone, it must be securely fastened to the base ►

plate. The mobile will be secure on the instrument panel and always within reach of the driver only by following these procedures. Mobile telephone connection with an external aerial is carried out subject to the hands-free device, via the telephone support or by the Bluetooth® connections present in the mobile telephone and the vehicle.

If the mobile telephone is connected to an aerial incorporated into the vehicle or an exterior aerial connected to the vehicle, this will help to reduce the electromagnetic radiation transmitted and the risk to human health. It will also improve the quality of the connection.

If the mobile telephone is used inside the vehicle without the hands-free system, it will not be securely fastened and will not be connected to the exterior aerial of the vehicle telephone. Nor will the telephone charge if it is not on the support. In addition, some calls may break off and the quality of the connection will be affected.

Mobile telephones should only be used inside the vehicle if they are connected to a hands-free system. SEAT recommends using an external aerial should you wish to use a mobile telephone inside the vehicle.

Bluetooth® is a registered trademark of Bluetooth® SIG, Inc.

 **WARNING**

If the mobile telephone is not securely fastened in position, it could be sent flying around the vehicle in the event of sharp braking, sudden manoeuvres or accident, causing injury.

- While driving, the mobile telephone, other equipment including telephone accessories such as telephone supports, notepads and navigators must be correctly secured, away from the airbags deployment zones, or stored in a safe place.

 **WARNING**

When using a mobile telephone or two-way radio without connecting an external aerial, the maximum permitted levels of electromagnetic radiation in the vehicle may be exceeded, thus putting the driver and the rest of the vehicle occupants in danger. This is also the case if the aerial has not been correctly installed.

- A minimum of 20 centimetres should be kept between mobile telephone aerials and artificial pacemakers, as mobile telephones may affect the working of pacemakers.
- Do not carry a mobile telephone in your breast pocket directly over the pacemaker when the mobile telephone is switched on.
- Immediately switch off the mobile telephone if you suspect any interference with pacemakers or other types of medical equipment. ■

SEAT Portable System*

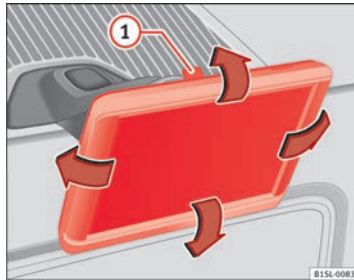


Fig. 125 In the centre console: Remove the navigator

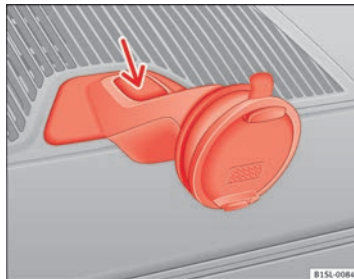




Fig. 126 Remove the navigator holder

The SEAT Portable System (supplied by SEAT) allows for the use of other vehicle functions such as additional applications ⇒ .

¹⁾ subject to the vehicle

The gradient and the angle of vision can be set by moving the navigator to the required position ⇒ Fig. 125 ⇒ .

The Portable Navigation System Instruction Manual can be observed directly on the equipment.


Functions¹⁾



- Multifunction display (MFI) shown with additional instruments ⇒ page 17.
- Operation of a factory-fitted radio and a ⇒ Booklet Radio system connected multimedia player.
- Image display.
- Navigation.
- Hands-free system for mobile telephones via Bluetooth.
- Door open.
- Optical parking system (OPS).
- Recommended gear and driving advice.

Observe the Instruction Manual in the equipment

- Connect the Portable Navigation System.
- Press the button **more** on the screen.
- Press the **Manual** button.
- Select the required chapter and press the corresponding button.


Removing and fitting the navigator

- Securely support the navigator.
- Press the release button  until the device is released from its holder.
- Take the navigator out and store it safely.

To fit the navigator, place it in the upper support and push the lower part inside the holder until it engages with a click ⇒  .

Removing and fitting the navigator holder

- Press the holder release button → Fig. 126 (arrow).
- Remove the holder from the dash panel in an upwards direction.
- If necessary, close the opening with the corresponding cover.

In order to fit the holder, place it on the opening from above and press in a downwards direction until it engages with a click. → .

WARNING

Any distraction may lead to an accident, with the risk of injury. Operating the navigator could distract you from the traffic.

- Always stay alert and drive responsibly.
- Select volume settings that allow you to easily hear signals from outside the vehicle at all times (e.g. emergency service sirens).
- Setting the volume too high may cause damage to your hearing. This also applies if the device is set to high volumes for a short period.

WARNING

Journey instructions and traffic signals shown on the navigation system may differ to the current traffic situation.

- Traffic signals and driving regulations take precedence over journey instructions and indications from the navigation system.
- Adjust your speed and driving style to visibility, road, traffic and weather conditions.

WARNING

If the navigator is not securely fastened in position, it could be sent flying around the vehicle in the event of sharp braking, sudden manoeuvres or accident, causing injury.

- Fit the navigator housing safely on the corresponding opening on the dash panel.
- Always place the navigator securely in its holder or store it safely in the vehicle.

CAUTION

An unsuitable gradient and angle of vision setting can damage the navigator.

- When adjusting the navigation device, move it with care and not beyond its limits.

CAUTION

Excessively high or low outside temperatures can affect the Portable Navigation System operation or damage the device.

- Always take the Portable Navigation System with you when you leave the vehicle to protect it from excessively high or low temperatures and intense sunlight.

CAUTION

Humidity can damage the Portable Navigation System connections on the dash panel.

- Do not clean the holder for the navigation device with moist products. Use a dry cloth.

Note

SEAT recommends taking the Portable Navigation System with you when you leave the vehicle to prevent it from being stolen. ■

Jacking points for raising vehicle

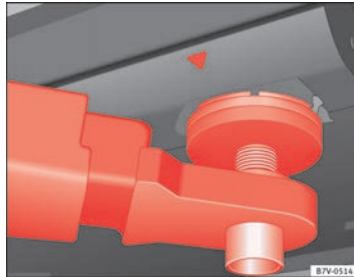


Fig. 127 Front jacking points for raising vehicle with lifting platform or jack

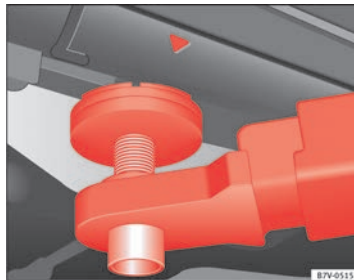


Fig. 128 Rear jacking points for raising vehicle with lifting platform or jack

Always use the jacking points indicated in the figures ⇒ Fig. 127 and ⇒ Fig. 128 when raising the vehicle. If the vehicle is not lifted at these points, it could be seriously damaged ⇒ ⚠ or lead to serious injury ⇒ ⚠.

The vehicle should not be lifted using lifting platforms with lift pads containing fluid.

When raising a vehicle using a platform or jack, a series of precautionary measures are required. Never raise the vehicle with a lifting platform or jack unless you have received training in how to do so and know how to lift the vehicle safely.

Notes on raising the vehicle with a jack ⇒ page 250.

⚠ WARNING

The improper use of the lifting platform or the jack when raising the vehicle may result in accidents or serious injury.

- Before raising the vehicle, please observe the manufacturer's instructions for the platform or jack, and the legal requirements, where applicable.
- There should not be anyone inside the vehicle when it is being raised or once it is in the air.
- Only use the jacking points indicated in the figures ⇒ Fig. 127 and ⇒ Fig. 128 when raising the vehicle. If the vehicle is not lifted at the indicated points, it may fall from the platform while the engine or gearbox is being dismantled, for example.
- The jacking points should be centrally aligned and firmly positioned on the platform support plates.
- Never start the engine when the vehicle is raised! The vehicle may fall from the platform due to the engine vibrations.
- If it is necessary to work underneath the vehicle while it is raised, you should check that the supporting stands have an adequate load capacity.
- Never climb onto the lifting platform.
- Always make sure that the weight of the vehicle does not exceed the lifting platform load capacity.

**CAUTION**


- Never raise the vehicle at the engine oil sump, the gearbox or the rear or front axles.
- Always use an **intermediate rubber support** to prevent damage to the vehicle underbody. Check that the arms of the lifting platform are able to move with obstruction.
- The arms should not come into contact with the side running boards or other parts of the vehicle. ■

Notes for the user

Introduction

Additional information and warnings:

- Exterior detail ⇒ page 6
- Accessories, parts replacement, repairs and modifications ⇒ page 222
- ⇒ Booklet Maintenance Programme

 **WARNING**

Failure to treat the vehicle with the correct care increases the risk of accident and injury.

- Observe legal requirements.
- Observe the Instruction Manual.

CAUTION

If you do not treat the vehicle suitably, you may cause it to be damaged.

- Observe legal requirements.
- Carry out regular maintenance of the vehicle, according to specifications in the Maintenance Programme.
- Observe the Instruction Manual.

Labels and plates

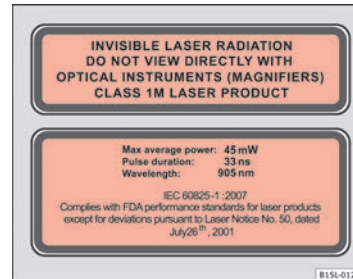


Fig. 129 Warnings relating to handling of the City Safety Assist system laser sensor function

Some parts in the engine compartment come from the factory with certificates of safety, labels or plates containing important information regarding the operation of the vehicle, for example, on the petrol cap, on the passenger's sun visor, on the driver door strut, or on the floor of the luggage compartment.

- Never remove these certificates of safety, labels or plates, and ensure they are kept in good condition and are legible.
- If a vehicle part, bearing a certificate of safety, label or plate, is replaced, the Specialised workshop should attach the information back in the same place.

Certificate of safety

A certificate of safety on the door strut states that all the safety standards and regulations established by the national traffic authorities responsible for road safety were met at the time of manufacture. It may also give the month and year of manufacture, together with the chassis number. ▶

Warning of high voltage label

There is a label close to the bonnet lock which warns of high voltage in the vehicle electrical installation.

Warning relating to the City Safety Assist system laser sensor

There are some warning and information signs on the City Safety Assist system laser sensor ⇒ Fig. 129.

Using your vehicle in other countries and continents

The vehicle is manufactured at the factory for use in a particular country in accordance with the national legislation in force at the time of manufacture.

If the vehicle is sold in another country or used in another country for an extended period of time, the applicable legislation of that country should be observed.

It may be necessary to fit or remove certain pieces of equipment or to deactivate certain functions. Service work may also be affected. This is particularly true if the vehicle is used in a different climate for an extended period of time.

As there are different types of frequency bands around the world, you may find that the radio system or the Portable Navigation System (supplied by SEAT) supplied at the factory does not work in another country.

**CAUTION**

- SEAT does not accept liability for any damage to the vehicle due to the use of a lower quality fuel, an inadequate service or the non-availability of genuine spare parts.
- SEAT does not accept liability if the vehicle does not comply in part or in full with the legal requirements of other countries or continents.

Radio reception and the aerial

For factory-fitted radio equipment, the aerial for radio reception is fitted to the roof of the vehicle.

**Note**

If electrical equipment such as mobile telephones, is used near a roof aerial, you may observe interference in the reception of AM stations.

Notes on SEAT repairs

Information about authorised SEAT services and authorised SEAT repairs can be requested by payment at the following addresses:

Clients in Europe, Asia, Australia, Africa, Central America and South America

Contact a Technical Service or specialised workshop, or request the corresponding documentation at www.erwin.volkswagen.de.

**WARNING**

Repairs or modifications which are not performed correctly may result in damage or errors in the vehicle operation, affecting the efficiency of the driver assist and airbag systems. This could result in serious accident.

- **Have any repairs or modifications carried out at a Specialised workshop.**

Conformity certification

The respective manufacturer hereby declares that the products indicated as follows fulfil the basic requirements and the following dispositions and ▶

important legislations on the date of manufacture of the vehicle, among others FCC Part 15.19, FCC Part 15.21 and RSS-Gen Issue 1:

Radio frequency equipment

- Electronic gearbox lock.
- Vehicle key.

Electrical equipment

- 12 volt socket. ■

Collection and scrapping of end-of-life vehicles

Collection of end-of-life vehicles

SEAT is already prepared for the moment when you wish to scrap your vehicle and offers you an environmentally-friendly solution. An extensive network of used vehicle reception centres already exists in much of Europe. After the vehicle has been delivered, you will receive a certificate of destruction describing the environmentally friendly scrapping of the vehicle in accordance with applicable legislation.

We will collect the used vehicle free of charge, provided it complies with all national legislation.

Please see your Technical Service for further information about the collection and scrapping of end-of-life vehicles.

Scrapping

The relevant safety requirements must be observed when the vehicle or components of the airbag or belt tensioner systems are scrapped. These requirements are known to qualified dealerships. ■

Engine management and exhaust gas purification system

Introduction

Additional information and warnings:

- Changing gear ⇒ page 124
- Refuelling ⇒ page 171
- Fuel ⇒ page 177
- Engine oil ⇒ page 185
- Vehicle battery ⇒ page 193
- Information stored in the control units ⇒ page 222
- Tow-starting and towing away ⇒ page 276





WARNING

The components of the exhaust system reach very high temperatures. This could cause a fire.

- Always park your vehicle so that no part of the exhaust system can come in contact with flammable materials (such as dried grass).
- Never apply additional underseal or anti-corrosion coatings to the exhaust pipes, catalytic converter or the heat shields on the exhaust system.

Control lamps

lights up	Possible cause	Solution
EPC	Fault in engine management (Electronic Power Control).	Take the vehicle to a Specialised workshop as soon as possible and have the engine checked.
	Fault in catalytic converter.	You should reduce speed accordingly. Drive carefully until you reach the next Specialised workshop. Have the engine checked there.
flashes	Possible cause	Solution
	Combustion fault which could damage the catalytic converter.	You should reduce speed accordingly. Drive carefully until you reach the next Specialised workshop. Have the engine checked there.

Several warning and control lamps light up for a few seconds when the ignition is switched on while a test of the function is being carried out. They will switch off after a few seconds.




CAUTION

Always pay attention to any lit lamps and to the corresponding descriptions and instructions to avoid damage to the vehicle.



Note

While the control lamps  or **EPC** maintain lit up, the engine will present faults, a higher consumption of fuel and a loss of engine power.

Catalytic converter

The catalytic converter permits the subsequent treatment of the exhaust gases thus reducing contaminating gas emissions. To ensure a longer working life for the exhaust system and catalytic converter in a petrol engine:

- Always use unleaded petrol.
- Never run the fuel tank completely dry.
- Do not top up with too much engine oil ⇒ page 185.
- Do not tow-start the vehicle; use the starter cables ⇒ page 273.

If you should notice misfiring, uneven running or loss of power when the vehicle is moving, reduce speed immediately. Have the vehicle inspected by a Specialised workshop. If this happens, unburnt fuel can enter the exhaust gas system and escape into the atmosphere. The catalytic converter can also be damaged by overheating.



For the sake of the environment

Even when the emission control system is working perfectly, there may be a smell of sulphur from the exhaust gas under some conditions. This depends on the sulphur content of the fuel used. ■

If and when

Practical information

Frequently asked questions

If you suspect that the vehicle has a fault or is damaged when using it, **before** consulting a SEAT dealership or a specialised workshop, carefully read the following instructions. Similarly, the terms in the alphabetical index “Things to note” or “Checklist” may be of help.

Problem	Possible causes, among others	Possible solution
The engine does not start.	The vehicle battery is flat.	– Carry out the jump start ⇒ page 273. – Charge the battery ⇒ page 193.
	You are using an incorrect vehicle key.	Use the correct key ⇒ page 28.
	The fuel tank level is insufficient.	Refuel ⇒ page 171.
The vehicle cannot be locked or unlocked with the key.	– Vehicle key battery is flat. – Too far away from the vehicle.	– Change the battery ⇒ page 28. – Move closer to the vehicle. – Synchronize the vehicle key ⇒ page 28.
	– Buttons pressed outside the radius of reach.	– Manually lock or unlock the vehicle ⇒ page 243.
Unusual noises.	Engine cold, City Safety Assist system, steering column electronic lock.	See entry “Noises” in the detailed alphabetical index.

Problem	Possible causes, among others	Possible solution
Handling is strange.	Assistance systems active.	See entry “Assistance systems” in the detailed alphabetical index.
	You are using an incorrect tyre pressure.	Check the tyre pressure ⇒ page 210.
	Damage to the wheel trims or tyres.	Inspect wheel trims and tyres regularly for damage ⇒ page 210 and replace them if necessary ⇒ page 250.
Vehicle has no jack, spare wheel or tire mobility set present.	Equipment subject to the vehicle.	No direct solution, depends on the equipment. In this case, you should contact a SEAT Dealership ⇒ page 246.
Surface not correctly illuminated.	– Headlights covered for driving on the left-hand side or right-hand side. – Headlight adjustment too high. – Faulty bulbs. – Dipped headlights switched off.	– Cover the headlights for driving on the left-hand side or right-hand side ⇒ page 84. – Adjust the headlight range ⇒ page 84. – Change the bulbs ⇒ page 264. – Switch on the dipped headlights ⇒ page 84. ▶

Problem	Possible causes, among others	Possible solution
The electrical equipment is not working.	Vehicle battery flat.	Charge the battery ⇒ page 193.
	Fuel tank level insufficient.	Refuel ⇒ page 171.
	A fuse is blown.	Check fuse and change if necessary ⇒ page 261.
Fuel consumption higher than normal.	– Short trips. – “Irregularities in the accelerator pedal”.	– Avoid short trips. – Foresight when driving. – Press the accelerator evenly.
	Electrical equipment connected.	Switch off any unnecessary electrical equipment.
	Fault in engine management.	Have the fault rectified ⇒ page 236.
	Tyre pressure too low.	Adjust tyre pressure ⇒ page 210.
	Driving on hills.	No direct solution.
	Driving with a heavy load.	No direct solution.
Driving at an excessive engine speed.	Shift up a gear.	

In case of emergency

Introduction

Additional information and warnings:

- Braking, stopping and parking ⇒ page 134
- Emergency locking and unlocking ⇒ page 243
- Vehicle tools ⇒ page 246
- Change wheel ⇒ page 250



WARNING

A faulty vehicle in traffic represents a risk of accident for the driver and for other road users.

- **Stop the vehicle safely as soon as possible. Park the vehicle a safe distance from surrounding traffic to lock all the doors in case of an emergency. Turn on the hazard warning lights to warn other road users.**
- **Never leave children or disabled people alone in the vehicle if the doors are to be locked. In case of an emergency, passengers will be trapped inside the vehicle. Individuals locked in the vehicle can be exposed to very high or very low temperatures.**


Protecting yourself and securing the vehicle





Fig. 130 Dash panel:
Button to switch on and off the hazard warning lights system

Always fulfil legal requirements for securing a broken down vehicle. In a number of countries it is now obligatory, for example, to turn on the hazard warning lights and use a reflective safety vest ⇒ page 242.

Checklist

For your own safety and that of other passengers, the following points should be observed in the order given ⇒ :

1. Park the vehicle a safe distance from traffic and on suitable ground ⇒ .
2. Turn on the hazard warning lights system with the button  ⇒ Fig. 130.
3. Apply the handbrake firmly ⇒ page 134.
4. Put the gearbox lever in neutral or the selector lever in position **P** ⇒ page 124.
5. Switch off the engine and remove the key from the ignition.
6. Have all occupants leave the vehicle and move to safety, for example behind a guard rail. ▶

Checklist (Continued)

7. When leaving the vehicle, take all keys with you.
8. Place an emergency warning triangle to indicate the position of your vehicle to other road users.
9. Allow the engine to cool and check if a specialist is required.

When being towed with the hazard warning lights system on, a change in direction or traffic lane can be indicated as usual using the turn signals lever. The hazard lights will be interrupted temporarily.

Examples of when to use the hazard warning lights system:

- If the vehicles ahead suddenly slow down or reach the end of a traffic jam, to warn the vehicles behind.
- In case of an emergency.
- If the vehicle breaks down.
- When tow-starting or towing.

Always comply with the applicable laws regarding the use of hazard warning lights.

If the hazard warning lights system is not working, you must use an alternative method of drawing attention to your vehicle. This method must comply with traffic legislation.

! WARNING

Failure to follow the checklist prepared for your own safety could lead to accidents and severe injuries.

- **Always complete the operations given in the checklist and observe the general rules of safety.**

! WARNING

The components of the exhaust system reach very high temperatures. This could cause a fire and considerable damage.

- **Always park your vehicle so that no part of the exhaust system can come in contact with flammable materials (such as dried grass or fuel).**

i Note

The vehicle battery will discharge and run down if the hazard warning lights remain on for too much time (even with the ignition turned off).

i Note

For some vehicles, the brake lights will blink when braking suddenly at speeds of approximately 80 km/h (50 mph) to warn vehicles behind. If braking continues, then the hazard warning lights system will automatically be turned on at the speed of less than approximately 10 km/h (6 mph). The brake lights remain lit. Upon accelerating, the hazard warning lights system will be automatically turned off. ■

First aid kit, warning triangle and fire extinguishers*

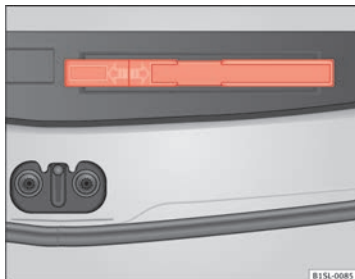


Fig. 131 In the luggage compartment: storage compartment for the warning triangle

Warning triangle

In some vehicle equipment it is possible to store the warning triangle model shown in a storage compartment of the luggage compartment → Fig. 131.

First-aid kit

The first aid kit must comply with legal requirements. Check the expiry date of the contents of the first aid kit.

Fire extinguisher

A fire extinguisher can be stored in a holder in the passenger seat footwell.

The fire extinguisher must conform to legal requirements, be ready for use and be checked regularly. Check the certification seal on the extinguisher.



WARNING

Loose objects in the interior can be violently thrown in case of a sudden manoeuvre or braking and especially in accidents causing serious injury.

- Secure or store fire extinguishers, first aid kit, reflective vests and warning triangle securely in the vehicle.

Emergency locking and unlocking

Introduction

The doors and rear lid can be locked manually and partially opened, for example if the key or the central locking is damaged.

Additional information and warnings:

- Vehicle key set ⇒ page 28
- Central locking and locking system ⇒ page 33
- Doors ⇒ page 38
- Rear lid ⇒ page 40
- In case of emergency ⇒ page 240

WARNING

Opening and closing doors carelessly can cause serious injury.

- If the vehicle is locked from outside, the doors and windows cannot be opened from the inside.
- Never leave children or disabled people alone in the vehicle. They could be trapped in the vehicle in an emergency and will not be able to get themselves to safety.
- Depending on the time of the year, temperatures inside a locked and closed vehicle can be extremely high or extremely low resulting in serious injuries and illness or even death, particularly for young children.

WARNING

Getting in the way of the doors and the rear lid is dangerous and can lead to serious injury.

- Open and close the doors and the rear lid only when there is nobody in the way.

CAUTION

When opening and closing in an emergency, carefully disassemble components and then reassemble them carefully to avoid damage to the vehicle. ■

Manually locking and unlocking the driver door

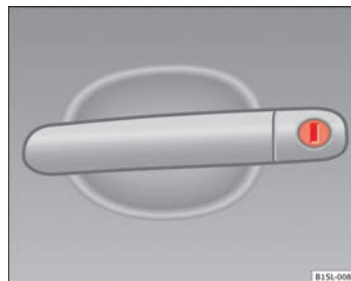


Fig. 132 Driver side door handle with lock cylinder

In general, when the driver door is locked all other doors are locked. Unlocking manually only opens the driver door.

- Unfold the key shaft if necessary ⇒ page 28.
- Insert the key shaft into the lock cylinder to unlock or lock the vehicle ⇒ Fig. 132. ■

Manually locking the passenger side door

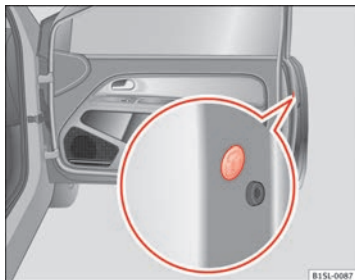



Fig. 133 In the front of the passenger side door: Emergency lock, hidden by a rubber cap



Fig. 134 Emergency locking of the vehicle using the vehicle key

The passenger door can be manually locked.

- Door open.
- Remove the rubber cap to the front of the door. The rubber cap is marked with a lock symbol  ⇒ Fig. 133.

- Unfold the key shaft if necessary ⇒ page 28.
- Insert the key shaft horizontally into the opening and moved the colour lever forwards ⇒ Fig. 134.
- Replace the rubber cap and close the door.
- Check if the door is locked.
- Have the vehicle checked by a Specialised workshop.



Note

The doors can be opened and unlocked individually from the inside by pulling the inside door handle. If necessary, pull the inner door release lever twice ⇒ page 33.

Emergency unlocking the rear lid

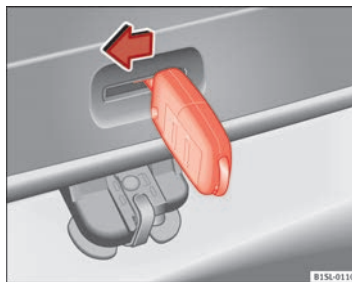


Fig. 135 From the luggage compartment: Manually unlocking the rear lid

- If necessary, fold the rear seat bench backrest forwards ⇒ page 55.
- Remove equipment to access the inside of the rear lid.

- Unfold the key shaft ⇒ page 28.
- Insert the key shaft into the rear lid opening ⇒ Fig. 135 and press the release lever in the direction of the arrow to unlock the rear lid. ■

Vehicle tool kit*

Introduction

When securing the vehicle in case of a breakdown, please note the legal requirements for each country.

Vehicle tool kit

For vehicles with a factory-fitted spare wheel or temporary spare wheel, in addition to winter wheels, the luggage compartment may contain additional vehicle tools ⇒ page 246.

Additional information and warnings:

- Working in the engine compartment ⇒ page 180
- In case of emergency ⇒ page 240
- Change wheel ⇒ page 250
- Tire Mobility Set ⇒ page 256

WARNING

When the vehicle tool kit, tire mobility set and spare wheel are loose in the interior they can be violently thrown in case of a sudden manoeuvre or braking and especially in accidents causing serious injury.

- Ensure that the vehicle tool kit, the tire mobility set and the spare wheel or temporary spare wheel are safely secured in the luggage compartment.

WARNING

Unsuitable or damaged vehicle tool kit can cause injury or accidents.

- Never work with inappropriate or damaged tools.

Location

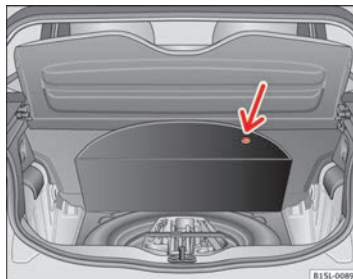


Fig. 136 In the luggage compartment: The carpet is raised

The vehicle tool kit, spare wheel, temporary spare wheel and the tire mobility set are stored in the luggage compartment under the carpeted floor panel ⇒ Fig. 136.

- If necessary, remove the luggage compartment variable floor ⇒ page 100.
- Raise the carpet at the recess (arrow) ⇒ Fig. 136.

Note

After use, return the jack to its initial position using the handle in order to securely store it in the vehicle.

Components

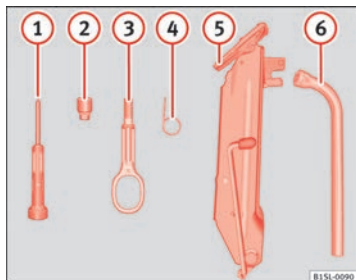


Fig. 137 Components of the vehicle tool kit

The set of on-board tools depends on the vehicle equipment. The following is a description for a vehicle with all options.

The individual elements of the vehicle tools ⇒ Fig. 137

- ① Screwdriver with hexagon socket in the handle for screwing and unscrewing the wheel bolts once loosened. The screwdriver bit is interchangeable. The screwdriver may be found underneath the wheel spanner.
- ② Adapter for antitheft bolt. SEAT recommend you carry the wheel bolt adapter in the vehicle tool kit at all times. The **code number** of the antitheft wheel bolt is stamped on the front of the adapter. In case it is lost, another adapter can be ordered using this number. Note the antitheft bolt code for the wheels and keep it in a place other than the vehicle.
- ③ Towing eye, removable.
- ④ Wire hook for pulling off the wheel trims, integral hubcaps and the wheel bolt caps.

- ⑤ Jack. Before storing the jack in the tool kit, fold its hook. The crank must then be folded tight against the side of the jack in order for it to be safely stored.
- ⑥ Wheel spanner.

Wheel trims

Introduction

Additional information and warnings:

- Caring for and cleaning the vehicle exterior ⇒ page 197
- Vehicle tools ⇒ page 246
- Change wheel ⇒ page 250
- Tire Mobility Set ⇒ page 256



WARNING

If the wheel trims are not appropriate or not fitted correctly, they could cause major accidents or damage.

- Incorrectly mounted wheel trims may come off while driving and endanger other road users.
- Damaged trims must never be mounted on the wheels.
- Always ensure that the brake ventilation and cooling is not cut off or blocked. This is also valid if hubcaps are fitted later. If there is not enough air, you may require significantly longer braking distances.



CAUTION

Remove and remount wheel trims taking care to avoid damage to the vehicle.

Hubcaps

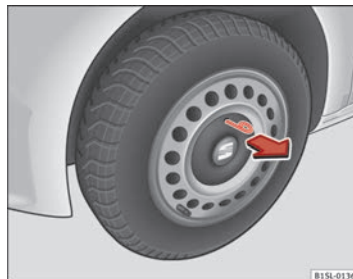


Fig. 138 Remove the hubcap of the steel wheel trim

In order to access the wheel bolts, first remove the hubcap.

Removing and fitting the hubcap

- To remove, take the vehicle tool kit wire hook and attach it to the edge of the wheel trim ⇒ Fig. 138.
- Remove the trim by pulling it in the direction of the arrow.
- To replace the hubcap, press the hubcap against the trim until it clicks into place.

The caps protect the wheel bolts and should be remounted after changing the tyre.

Full hubcaps

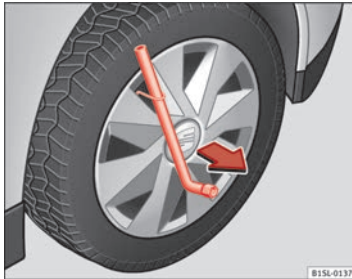


Fig. 139 Removing the full hubcap

Removing the full hubcap

- Take the wheel brace and the wire hook from the vehicle tool kit ⇒ page 246.
- Hook the wire through one of the grooves on the hubcap.
- Insert the wheel brace onto the wire hook ⇒ Fig. 139 and pull the hub cap in the direction shown by the arrow.

Fitting hubcaps

Press the hubcap against the wheel so that the space for the valve fits over the tyre valve. Make sure that the hubcap is correctly fitted all the way around the wheel. If you are using an anti-theft wheel lock, screw it in the opposite position to the valve. ■

Wheel bolt caps



Fig. 140 Removing the wheel bolt caps

- Take the wire hook from the vehicle tool kit ⇒ page 246.
- Insert the wire hook in the cap through the opening ⇒ Fig. 140 and pull outwards in the direction of the arrow.

The caps protect the wheel bolts and should be remounted after changing the tyre.

The **anti-theft wheel locking bolt** has a special cap. This cap only fits on anti-theft locking bolts and is not for use with standard wheel bolts. ■

Changing a wheel

Introduction

Some vehicle versions and models do not have a factory-fitted jack or box spanner. In this case, we recommend consulting a Specialised workshop to change the wheel.

You should only change the wheels yourself if the vehicle is parked in a safe place, you are familiar with the procedure and you have all the necessary tools! Otherwise, you should seek professional assistance.

Additional information and warnings:

- Exterior detail ⇒ page 6
- Vehicle key set ⇒ page 28
- Wheels and tyres ⇒ page 210
- In case of emergency ⇒ page 240
- Vehicle tools ⇒ page 246
- Wheel trims ⇒ page 248



WARNING

Changing a wheel can be dangerous, especially on the hard shoulder. Please observe the following rules to minimise the risk of injury:

- Stop the vehicle safely as soon as possible. Park your vehicle as safe distance from surrounding traffic to change a wheel.
- When changing a wheel, keep all passengers and particularly children a safe distance away from the work area.
- Turn on the hazard warning lights to warn other road users.
- Ensure the ground on which you park is flat and solid. If necessary, support the jack on a wide solid base.



WARNING (Continued)

- If you are changing a wheel yourself, you should be familiar with the required procedure. Otherwise, you should seek professional assistance.
- Only use suitable tools that are not damaged when changing a wheel.
- Always stop the engine, apply the handbrake lever firmly and place the selector lever in position P, or engage a gear for a manual gearbox to reduce the risk of the vehicle moving accidentally.
- Have the tightening torque of the wheel bolts checked as soon as possible with a reliable torque wrench.

Preparations for changing a wheel

Check list

Before changing a wheel, complete the following operations in the order given ⇒ ⚠:

1. In the event of a flat tyre, park the vehicle a safe distance from traffic and on suitable ground.
2. Apply the handbrake firmly ⇒ page 134.
3. Automatic gearbox: move the selector lever to position **P** ⇒ page 124.
4. Stop the engine and remove the key from the ignition ⇒ page 119.
5. Manual gearbox: Select a gear ⇒ page 124.
6. Have all vehicle occupants get out of the vehicle and wait in a safe place (for example, behind the safety barrier).
7. Check the wheel opposite the wheel being changed with a stone or similar object.
8. If the luggage compartment is full: take the baggage out of the vehicle.
9. Remove the spare wheel or the temporary spare wheel and the vehicle tool kit from the luggage compartment.
10. Remove the wheel trims ⇒ page 248.

⚠ WARNING

Failure to follow the checklist prepared for your own safety could lead to accidents and severe injuries.

- Always complete the operations given in the checklist and observe the general rules of safety.

Wheel bolts

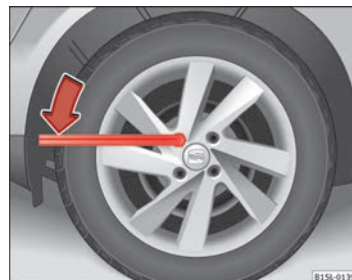


Fig. 141 Changing the wheel: Slacken the wheel bolts

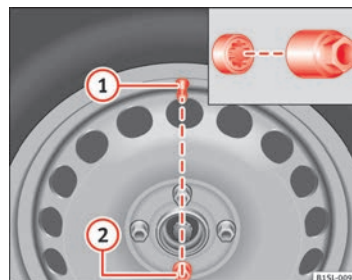


Fig. 142 Changing the wheel: Tyre valve ① and position of anti-theft wheel locking bolt ②

Only use the tool supplied with the vehicle to loosen the wheel bolts.

Loosen the wheel bolts only about one turn before raising the vehicle with the jack. ▶

If the wheel bolt is very tight, you may be able to loosen it by pushing down on the end of the wheel brace carefully with your foot. Hold on to the vehicle for support and take care not to slip.

Loosening wheel bolts

- Fit the wheel brace as far as it will go over the wheel bolt ⇒ Fig. 141.
- Hold the wheel brace at the end and rotate the bolt approximately *one* turn anticlockwise ⇒ ⚠.

Loosening anti-theft wheel bolts

For wheels with full hubcap, the anti-theft wheel lock must be threaded into position ⇒ Fig. 142 Ⓞ before mounting the hubcap. Otherwise it will not be possible to mount the full hubcap.

- Take the adapter for anti-theft wheel bolts out of the vehicle tool kit.
- Insert the adapter onto the wheel bolt ⇒ Fig. 142. Push it on as far as it will go.
- Fit the wheel brace onto the adapter as far as possible.
- Hold the wheel brace at the end and rotate the bolt approximately *one* turn anticlockwise ⇒ ⚠.

Important information about wheel bolts

The wheel rims and bolts have been designed to be fitted to factory options. If different rims are fitted, the correct wheel bolts with the right length and correctly shaped bolt heads must be used. This ensures that wheels are fitted securely and that the brake system functions correctly.

In some circumstances, wheel bolts from the same model vehicle should not be used.

Wheel bolt tightening torque

The prescribed tightening torque for wheel bolts for steel and alloy wheels is **110 Nm**. Have the tightening torque of the wheel bolts checked as soon as possible with a reliable torque wrench.

If wheel bolts are rusty and it is difficult to tighten them, the threads should be replaced and cleaned **before checking the tightening torque**.

Never grease or lubricate wheel bolts or the wheel hub threads. Although they have been tightened to the prescribed torque, they could come loose while driving.



WARNING

If the wheel bolts are not fitted correctly they could be released while driving leading to loss of vehicle control and serious damage.

- **Only use wheel bolts which correspond to the wheel rims in question.**
- **Never use different wheel bolts.**
- **The bolts and threads should be clean, free of oil and grease and easy to thread.**
- **To loosen and tighten the wheel bolts, always use the wheel brace supplied with the vehicle.**
- **Loosen the wheel bolts only about one turn before raising the vehicle with the jack.**
- **Never grease or lubricate wheel bolts or the wheel hub threads. Although they have been tightened to the prescribed torque, they could come loose while driving.**
- **Never loosen the bolted joints of wheel trims with bolted ring trims.**
- **If the wheel bolts are not tightened to the correct torque, they may come loose while driving, and the bolts and rims may come out. If the tightening torque is too high, the wheel bolts and threads can be damaged.**

Raising the vehicle with the jack

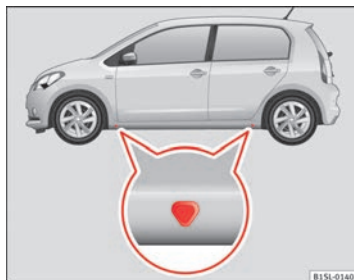


Fig. 143 Jack position points

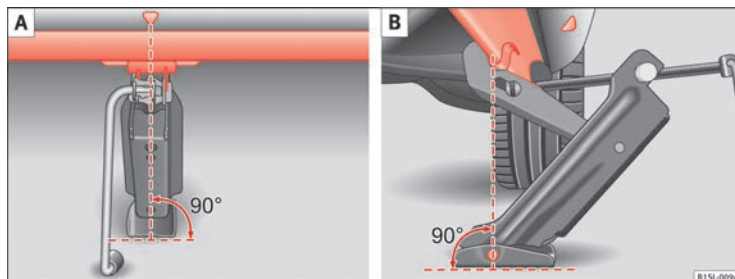


Fig. 144 jack mounted on the left rear part of the vehicle

The jack may be applied only at the jacking points shown (marks on chassis) ⇒ Fig. 143. Always the relevant jacking point for the wheel to be changed ⇒ ⚠.

Raise the vehicle using only the designated jacking points. ▶

Vehicle diagram

Prior to a journey...


While driving

Care, cleaning and maintenance

If and when

Technical Data

Check list

For your own safety and that of other passengers, the following points should be observed in the order given ⇒ :

1. Select a suitable flat and firm surface for raising the vehicle.
2. Switch off the engine, engage a gear (manual gearbox) or place the selector lever in position P ⇒ page 124 and engage the handbrake ⇒ page 134.
3. Block the wheel diagonally opposite the wheel being changed with collapsible wheel chocks or other suitable objects.
4. Loosen the wheel bolts on the wheel to be changed ⇒ page 251.
5. Look below the vehicle for the jacking point ⇒ Fig. 143 closest to the tyre which has to be changed.
6. Raise the jack with the handle until it can be inserted below the jacking point.
7. Ensure that the foot of the jack is firmly on the ground and that it is placed, at a vertical angle, immediately below the lifting point on the vehicle ⇒ Fig. 144.
8. Straighten the jack and continue raising it using the handle until the claw holds the vertical reinforcement beneath the vehicle ⇒ Fig. 144.
9. Raise the vehicle until the wheel is clear of the ground.



WARNING

If the vehicle is not correctly raised, it could fall off the jack causing serious injury. Please observe the following rules to minimise the risk of injury:

- You should only use a jack approved by SEAT for your vehicle. Other jacks, even those approved for other SEAT models, might slip out of place.



WARNING (Continued)

- The ground should be firm and flat. If the ground is sloped or soft then the vehicle could slip and fall off the jack. If necessary, support the jack on a wide solid base.
- If the ground is slippery (for example, on tiles), place a non-slip surface (for example a floor mat) beneath the jack to avoid slipping.
- Only fit the jack at the prescribed jacking points. The claw of the jack should grip the reinforcement nerve on the underbody ⇒ Fig. 144.
- You should never have any limbs beneath a raised vehicle which is only supported by a jack.
- If you have to work underneath the vehicle, you must use suitable stands additionally to support the vehicle, there is a risk of accident!
- Never raise the vehicle if it is tilting to one side or the engine is running.
- Never start the engine when the vehicle is raised. The vehicle may come loose from the jack due to the engine vibrations.



WARNING

Failure to follow the checklist prepared for your own safety could lead to accidents and severe injuries.

- Always complete the operations given in the checklist and observe the general rules of safety.

Changing a wheel



Fig. 145 Changing the wheel: loosen wheel bolts with the socket at the end of the wheel brace

Removing the wheel

- Please observe the check list ⇒ page 251.
- Loosen the wheel bolts ⇒ page 251.
- Jacking up the vehicle ⇒ page 253.
- Using the hexagonal socket in the wheel brace ⇒ Fig. 145, unscrew the slackened wheel bolts and place them on a clean surface.
- Take off the wheel.

How to use the spare wheel or temporary spare wheel

Check the direction of rotation of the tyre ⇒ page 218, Tyre code.

- Place the spare wheel or temporary spare wheel into position.
- Replace the wheel bolts and tighten *slightly* using the hexagonal socket on the end of the wheel brace.
- To tighten the anti-theft locking wheel bolts use the corresponding adaptor.
- Lower the vehicle with the jack.

- Tighten all of the wheel bolts clockwise ⇒ ⚠. Tighten the bolts in diagonal pairs (not in a circle).
- Put the caps, trim or full hubcap back on ⇒ page 248.

⚠ WARNING

If the wheel bolts are not treated suitably or not tightened to the correct torque then this could lead to loss of vehicle control and to a serious accident.

- All the wheel bolts and hub threads should be clean and free of oil and grease. The wheel bolts should be easily tightened to the correct torque.
- The hexagonal socket in the wheel brace should be used for turning wheel bolts only. Do not use it to loosen or tighten the wheel bolts.

After changing the wheel

- Clean the vehicle tools, if necessary and put them away in the luggage compartment foam holder ⇒ page 246.
- Store the spare wheel, the temporary spare wheel or the changed wheel securely in the luggage compartment.
- Have the tightening torque of the wheel bolts checked as soon as possible with a torque wrench ⇒ page 252.
- Have the flat tyre replaced as quickly as possible.

Anti-puncture kit*

Introduction

The Tyre Mobility Set* will reliably seal punctures caused by the penetration of a foreign body of up to about **4 mm** in diameter. **Do not remove foreign objects, e.g. screws or nails, from the tyre.**

After inserting the sealant residue in the tyre, you must again check the tyre pressure about 10 minutes after starting the engine.

You should only use the tyre mobility set if the vehicle is parked in a safe place, you are familiar with the procedure and you have the necessary tyre mobility set! Otherwise, you should seek professional assistance.

The tyre sealant must not be used in the following cases:

- If the wheel rim has been damaged.
- In outside temperatures below -20 °C (-4 °F).
- In the event of cuts or perforations in the tyre greater than 4 mm.
- If you have been driving with very low pressure or a completely flat tyre.
- If the sealant bottle has passed its use by date.

Additional information and warnings:

- Vehicle key set ⇒ page 28
- Braking, stopping and parking ⇒ page 134
- Wheels and tyres ⇒ page 210
- In case of emergency ⇒ page 240
- Wheel trims ⇒ page 248



WARNING

Using the tyre mobility set can be dangerous, especially when filling the tyre at the roadside. Please observe the following rules to minimise the risk of injury:

- Stop the vehicle safely as soon as possible. Park your vehicle as safe distance from surrounding traffic to fill the tyre.
- Ensure the ground on which you park is flat and solid.
- All passengers and particularly children must keep a safe distance from the work area.
- Turn on the hazard warning lights to warn other road users.
- Use the tyre mobility set only if you are familiar with the necessary procedure. Otherwise, you should seek professional assistance.
- The tyre mobility set is intended for temporary, emergency use only. Use only until you can reach the nearest specialised workshop.
- Replace the repaired tyre with the tyre mobility set as soon as possible.
- The sealant is a health hazard and must be cleaned immediately if it comes into contact with the skin.
- Always keep the tyre mobility set out of the reach of small children.
- Never use the approved jack, even if it has been approved for your vehicle.
- Always stop the engine, apply the handbrake lever firmly and engage gear if using a manual gearbox, in order to reduce the risk of vehicle involuntary movement.



WARNING

A tyre filled with sealant does not have the same performance properties as a conventional tyre.

- Never drive faster than 80 km/h (50 mph).

⚠ WARNING (Continued)

- Avoid heavy acceleration, hard braking and fast cornering.
- Drive only during 10 minutes at a maximum speed of 80 km/h (50 mph) and subsequently check the tyre.



For the sake of the environment

Dispose of used or expired sealant observing any legal requirements.



Note

A new bottle of sealant can be purchased at SEAT dealerships.



Note

Take into account the separate instruction manual of the tire mobility set manufacturer*.

Components of the tire mobility set*

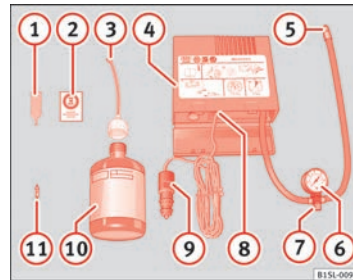


Fig. 146 Standard representation: Contents of the tire mobility set

The tire mobility set is located underneath the floor covering in the luggage compartment. It includes the following components ⇒ Fig. 146:

- 1 Tyre valve remover
- 2 Sticker indicating maximum speed “max. 80 km/h” or “max. 50 mph”
- 3 Filler tube with cap
- 4 Air compressor
- 5 Tube for inflating tyres
- 6 Warning provided by tyre pressure monitoring system¹⁾
- 7 Air bleed screw²⁾
- 8 ON/OFF switch
- 9 12 volt connector

¹⁾ A compressor may also be included.

²⁾ In its place, the compressor may have a button.

- ⑩ Bottle of sealant¹⁾
- ⑪ Spare tyre valve

The **valve insert remover** ① has a gap at the lower end for a valve insert. The valve insert can only be screwed or unscrewed in this way. This also applies to its replacement part ⑪.

Preparation

Checklist

Before filling a tyre, complete the following operations in the order given ⇒ ⚠:

1. In the event of a puncture, park the vehicle as far as possible from traffic and on flat, suitable ground.
2. Apply the handbrake firmly ⇒ page 134.
3. Stop the engine and remove the key from the ignition ⇒ page 119.
4. Manual gearbox: Select a gear ⇒ page 124.
5. Have all vehicle occupants get out of the vehicle and wait in a safe place (for example, behind the safety barrier).
6. Switch on the hazard warning lights and set the warning triangle in position ⇒ page 240. Observe legal requirements.
7. Check whether a repair is possible using the Tyre Mobility Set ⇒ page 256
8. If the luggage compartment is full: take the baggage out of the vehicle.
9. Remove the tyre mobility set from the luggage compartment.
10. Apply the sticker ⇒ Fig. 146 ② from the tyre mobility set to the dash panel where it can be seen clearly.
11. **Do not** remove foreign objects, e.g. screws or nails, from the tyre.

¹⁾ A compressor may also be included.



WARNING

Failure to follow the checklist prepared for your own safety could lead to accidents and severe injuries.

- Always complete the operations given in the checklist and observe the general rules of safety.

Sealing and inflating a tyre

Sealing a tyre

- Unscrew the tyre valve cap.
- Use the corresponding enclosed extractor ⇒ Fig. 146 ① to unscrew the tyre valve insert. Place the valve insert on a clean surface.
- Vigorously shake the sealant bottle ⇒ Fig. 146 ⑩ for several seconds.
- Screw the inflator tube ⇒ Fig. 146 ③ securely into the sealant bottle in a clockwise direction. The seal on the mouth of the bottle moves automatically.
- Remove the lid from the filling tube ⇒ Fig. 146 ③ and screw the open end of the tube into the tyre valve.
- Hold the tyre sealant can upside down and fill **the complete** contents of the can into the tyre.
- Remove the tyre sealant bottle from the valve.
- Screw the valve insert again with the corresponding enclosed extractor ⇒ Fig. 146 ① into the tyre valve.

Inflating the tyre

- Securely screw the tyre inflator tube ⇒ Fig. 146 ⑤ of the compressor in to the tyre valve.
- Check whether the air bleed screw ⇒ Fig. 146 ⑦ is closed. ▶

- Start the vehicle engine and leave it running.
- Attach the connector ⇒ Fig. 146 ⑨ to a 12 volt socket of the vehicle ⇒ page 117.
- Connect the air compressor with the ON/OFF switch ⇒ Fig. 146 ⑧.
- Keep the air compressor running until it reaches 2.0 to 2.5 bar (29-36 psi / 200-250 kPa) ⇒ ⚠. **Maximum operation time 8 minutes** ⇒ ⑩.
- Disconnect the air compressor.
- If it is **not possible to achieve** an air pressure of 2.0 to 2.5 bar (29-36 psi / 200-250 kPa), unscrew the tyre inflator tube from the tyre valve.
- Move the vehicle some 10 metres forwards or backwards so that the sealant is evenly distributed in the tyre interior.
- Securely screw the compressor tyre inflator tube into the tyre valve and repeat the inflation process.
- If the indicated pressure can still not be reached, the tyre is too badly damaged. The tyre cannot be sealed with the anti-puncture kit. Do not continue driving. You should obtain professional assistance ⇒ ⚠.
- Disconnect the air compressor and unscrew the flexible inflator tube from the tyre valve.
- When the tyre pressure is between 2.5 and 2.0 bars, immediately continue driving without exceeding 80 km/h (50 mph).
- After **10 minutes**, Check the pressure again ⇒ page 259.

⚠ WARNING

When inflating the wheel, the air compressor and the inflator tube may become hot.

- Protect hands and skin from hot parts.
- Do not place the hot flexible inflator tube or hot air compressor on flammable material.

⚠ WARNING (Continued)

- Allow them to cool before storing the device.
- If it is not possible to inflate the tyre to at least 2.0 bars (29 psi / 200 kPa), the tyre is too badly damaged. The sealant is not in a good condition to seal the tyre. Do not continue driving. You should obtain professional assistance.

⚠ CAUTION

Switch off the air compressor after a maximum of 8 operational minutes to avoid overheating! Before switching on the air compressor again, let it cool for several minutes.

Check after 10 minutes of driving

Screw the inflator tube ⇒ Fig. 146 ⑤ again and check the pressure on the gauge ⑥.

1.3 bar (19 psi / 130 kPa) and lower:

- **Stop the vehicle!** The tyre cannot be sealed sufficiently with the tyre mobility set.
- You should obtain professional assistance ⇒ ⚠.

1.4 bar (20 psi / 140 kPa) and higher:

- Set the tyre pressure to the correct value again ⇒ page 210.
- Carefully resume your journey until you reach the nearest specialised workshop without exceeding 80 km/h (50 mph).
- Have the damaged tyre replaced.

**WARNING**

Driving with an unsealed tyre is dangerous and can cause accidents and serious injury.

- Do not continue driving if the tyre pressure is 1.3 bar (19 psi / 130 kPa) and lower.
- You should obtain professional assistance.

Fuses

Introduction

Due to the constant update of vehicles, fuse assignments depending on equipment and the use of the same fuse for various electrical components, at the time of printing this manual it is not possible to provide an up-to-date summary of the electrical components fuse positions. For detailed information about the fuse positions, please consult a Technical Service.

In general, a fuse can be assigned to various electrical components. Likewise, an electrical component can be protected by several fuses.

Only replace fuses when the cause of the problem has been solved. +If a newly inserted fuse blows after a short time, you must have the electrical system checked by a Specialised workshop as soon as possible.

Additional information and warnings:

- Working in the engine compartment ⇒ page 180



WARNING

The high voltages in the electrical system can give serious electrical shocks, causing burns and even death!

- Never touch the electrical wiring of the ignition system.
- Take care not to cause short circuits in the electrical system.



WARNING

Using unsuitable fuses, repairing fuses or bridging a current circuit without fuses can cause a fire and serious injury.

- Never use a fuse with a higher value. Only replace fuses with a fuse of the same amperage (same colour and markings) and size.
- Never repair a fuse.
- Never replace a fuse by a metal strip, staple or similar.



CAUTION

- To avoid damage to the vehicles electric system, before replacing a fuse turn off the ignition, the lights and all electrical elements and remove the keys from the ignition.
- If you replace a fuse with higher-rating fuse, you could cause damage to another part of the electrical system.
- Protect the fuse boxes when open to avoid the entry of dust or humidity. Dirt and humidity inside fuse boxes can cause damage to the electrical system.



Note

One single consumer could have more than one fuse.



Note

Several consumers could run over one single fuse. ■

Vehicle fuses

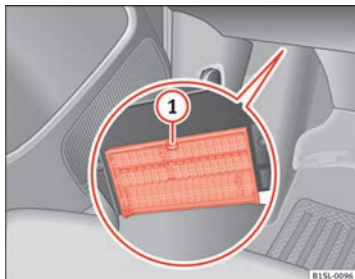


Fig. 147 Below the driver side dash panel: fuse box cover

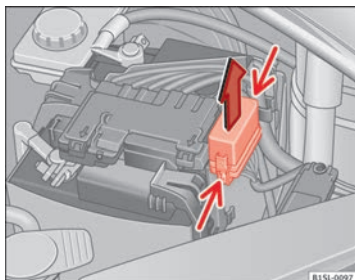


Fig. 148 In the engine compartment: fuse box cover

Only replace fuses with a fuse of the same amperage (same colour and markings) and size.

Identifying fuses situated below the driver-side dash panel by colours

Colour	Amp rating
Purple	3
Light brown	5
Brown	7,5
Red	10
Blue	15
Yellow	20
White or transparent	25
Green	30
Orange	40

Opening and closing the fuse box situated below the dash panel

- *Opening*: press the unlock button ⇒ Fig. 147 ① until it is possible to open the cover.
- Fold the cover down.
- *Closing*: fold the cover up in the opposite direction to the arrow until it clicks into the locking lever ①.

Opening the engine compartment fuse box

- Open the bonnet Δ ⇒ page 180.
- Press the attachment tabs in the direction indicated by the arrow (thin arrows) to release the fuse box cover ⇒ Fig. 148.
- Then lift the cover out.
- To **fit** the cover, place it on the fuse box. Push the attachment tabs down, in the opposite direction indicated by the arrow until they click audibly into place. ▶

! CAUTION

- Always carefully remove the fuse box covers and refit them correctly to avoid problems with your vehicle.
- Protect the fuse boxes when open to avoid the entry of dust or humidity. Dirt and humidity inside fuse boxes can cause damage to the electrical system.

i Note

In the vehicle, there are more fuses than those indicated in this chapter. These should only be changed by a Specialised workshop. ■

Replacing a blown fuse

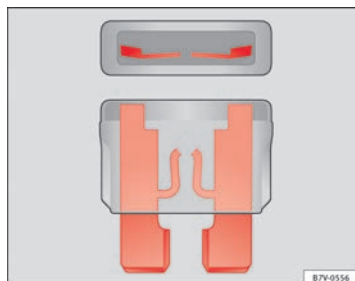


Fig. 149 Image of a blown fuse

Preparation

- Switch off the ignition, lights and all electrical equipment.
- Open the corresponding fuse box ⇒ page 262.

Identifying a blown fuse

A fuse is blown if its metal strip is ruptured ⇒ Fig. 149.

Point a lamp at the fuse. This will make it easier to see if the fuse is blown.

To replace a fuse

- Remove the fuse.
- Replace the blown fuse for one with an *identical* amperage rating (same colour and markings) and *identical* size ⇒ **!**.
- Replace the cover again or close the fuse box lid.

! CAUTION

If you replace a fuse with higher-rating fuse, you could cause damage to another part of the electrical system. ■

Changing bulbs

Introduction

Changing bulbs requires a certain amount of manual skill. If you are unsure, SEAT recommends that you consult a Technical Service or request assistance from a specialist. In general a specialist is needed if, in addition to the bulbs, other vehicle components require removal.

You should store spare light bulbs in the vehicle for safety-relevant lights. Spare bulbs may be obtained from the Official dealers and workshops. In some countries, it is a legal requirement to carry spare bulbs in the vehicle.

Driving with faults and blown bulbs on the vehicle exterior lighting is against the law.

Additional bulb specifications

The specifications of some headlamp bulbs and bulbs for the tail lamps fitted at the factory may be different to those of conventional bulbs. Bulb information is displayed on the bulb socket or on the bulb itself.

Additional information and warnings:

- Exterior detail ⇒ page 6
- Lights and visibility ⇒ page 84
- Working in the engine compartment ⇒ page 180
- Vehicle tools ⇒ page 246
- Fuses ⇒ page 261



WARNING

If the road is not well-lit and the vehicle is not clearly visible to other drivers, there is a risk of accident.



WARNING

Failure to replace bulbs correctly may cause serious accidents.

- Before carrying out any work in the engine compartment please read and observe the warnings ⇒ page 180. In any vehicle, the engine compartment is a hazardous area and could cause severe injury.
- The bulbs H4, HB4 and H7 are pressurised and might explode on changing them.
- Only replace the bulbs concerned when they have cooled.
- Never replace bulbs alone if you are not familiar with the operations necessary. If you are not sure about procedures then visit a Specialised workshop to carry out the necessary work.
- Never touch the bulb glass directly. Fingerprints will be evaporated by the heat of the operating bulb thus "fogging" up the reflector.
- The headlamp frameworks in the engine compartment and the tail lamps contain sharp elements. Always protect your hands when changing bulbs.



CAUTION

After changing a bulb, if the rubber covers are not replaced correctly on the headlamp framework, the electrical installation may be damaged, especially if water is allowed to enter. ■

Information for replacing bulbs

Checklist

To replace a bulb, carry out the following operations always in the order given ⇒ ⚠:

1. Park the vehicle a safe distance from traffic and on suitable ground.
2. Apply the handbrake firmly ⇒ page 134.
3. Turn the light switch to position **0** ⇒ page 84.
4. Move the gear lever into the neutral position ⇒ page 84.
5. Stop the engine and remove the key from the ignition ⇒ page 119.
6. Automatic gearbox: move the selector lever to position **P** ⇒ page 124.
7. Manual gearbox: Select a gear ⇒ page 124.
8. Allow the corresponding bulb to cool.
9. Visually inspect fuses to see if any are blown ⇒ page 261.
10. Replace the bulb according to the instructions ⇒ ⚠. Bulbs should only be replaced by new identical models. Bulb information is displayed on the bulb socket or on the bulb itself.
11. In general, never touch the bulb glass directly. The heat of the bulb would cause the fingerprint to evaporate and condense on the reflector. This will impair the brightness of the headlight.

12. Check if the new bulb is working. If the bulb is not working, it may not have been correctly fitted, it could be damaged or the connector may not be correctly connected.
13. Every time a bulb for the headlights is replaced, visit a specialised workshop to check the headlights.



WARNING

Failure to follow the checklist prepared for your own safety could lead to accidents and severe injuries.

- Always complete the operations given in the checklist and observe the general rules of safety.



CAUTION

Always remove and fit headlights carefully to avoid damage to the paintwork and other vehicle parts.

Replacing the bulbs in the headlights

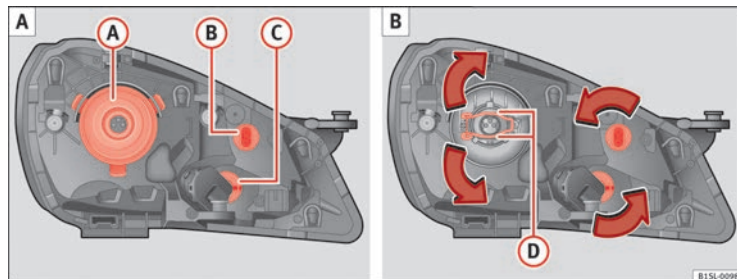


Fig. 150 In the engine compartment: Rear view of the front left headlight with rubber cover: (A) dipped beam and main beam headlights, (B) side lights and daytime driving lights and (C) turn signal

There is no need to remove the headlight to replace bulbs.

Complete operations only in the sequence given:

⇒ Fig. 150	(A) Dipped beam and main beam headlights	(B) Side light and daytime driving light	(C) Turn signals (front)
1.	Always take the checklist into account and take the necessary actions ⇒ page 265.		
2.	Open the bonnet Δ ⇒ page 180.		
3.	Remove the bulb connector H4. Remove the rubber cover using the tabs. Press the retaining clip (D) downwards in the direction of the arrow, and unclip sideways and remove it.	Turn the bulb holder in an anticlockwise direction as far as it will go and remove it, along with the bulb, pulling backwards.	
4.	Remove the bulb from the holder. If necessary, press the lock on the bulb holder.		
5.	Replace the faulty bulb by a new identical bulb. ▶		

Complete operations only in the sequence given:

	A	B	C
⇒ Fig. 150	Dipped beam and main beam headlights	Side light and daytime driving light	Turn signals (front)
6.	Insert the bulb, return it to its position and insert the retaining clip D.	Insert the bulb holder in the headlight and turn it clockwise as far as the stop.	Insert the bulb holder in the headlight and turn it clockwise as far as the stop.
7.	Place the rubber cover and check that is correctly in position. Insert the connector to the bulb H4.		



Note

The images show the left hand headlight from behind. The structure of the right hand side headlight is symmetric.

Replacing the front bumper bulbs

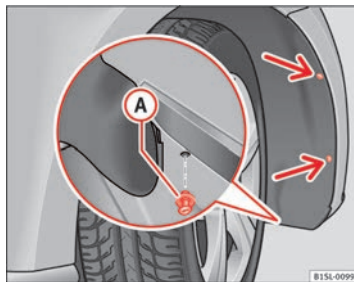


Fig. 151 In the front right wheel arch: Remove the retaining screws (arrows) and take out the expansive rivet (A).

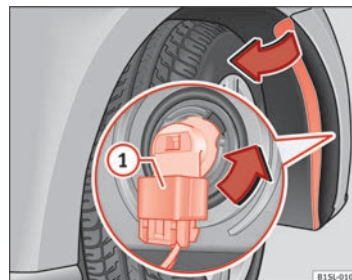


Fig. 152 Changing the bulbs in the headlights

Complete operations only in the sequence given:

1. Always take the checklist into account and take the necessary actions ⇒ page 265.
2. Unscrew the 2 retaining screws of the wheel arch trim ⇒ Fig. 151 (arrows) with the screwdriver from the vehicle tool kit ⇒ page 246.
3. Unscrew the expansive rivet in the lower front part of the wheel arch trim (A) with the screwdriver from the vehicle tool kit and completely remove it ⇒ page 246.
4. Carefully fold the wheel arch trim to the side.
5. Release the connector ⇒ Fig. 152 ① and remove it.

Vehicle diagram

Prior to a journey...

While driving

Care, cleaning and maintenance

If and when

Technical Data

Complete operations only in the sequence given:

6. Turn the bulb holder ⇒ Fig. 152 in the direction of the arrow, **in an anticlockwise direction** as far as it will go and remove it, along with the bulb, pulling backwards.
7. Replace the faulty bulb by a new identical bulb.
8. Insert the bulb holder in the headlight and turn it **clockwise** as far as the stop.
9. Plug the connector ① into the bulb holder. The connector must audibly click into place.

Complete operations only in the sequence given:

10. Replace the wheel arch trim into its position.
11. Place the expansive rivet in the wheel arch trim and bumper and press it completely inwards ⇒ Fig. 151 (A).
12. Securely screw the 2 retaining screws ⇒ Fig. 151 (arrows) with a screwdriver. ■

Changing the bulbs in the rear lights

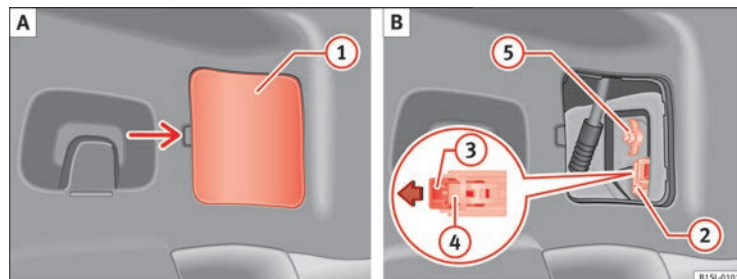


Fig. 153 On the side of the luggage compartment: TO: Remove the cover, B: Removing the tail light units

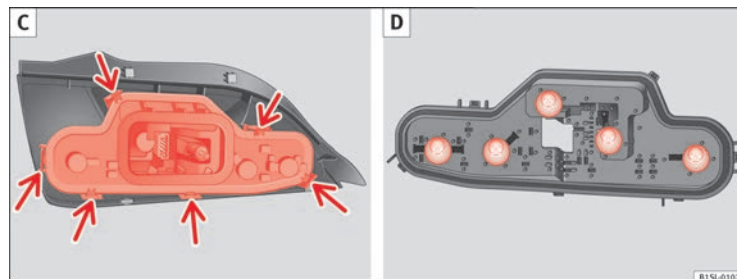


Fig. 154 Tail light unit: C: Remove the bulb holder, D: Remove the bulbs

Complete operations only in the sequence given.

Removing the tail light units

1. Always take the checklist into account and take the necessary actions → page 265.
2. Open the rear lid → page 40.

Vehicle diagram

Prior to a journey...

While driving

Care, cleaning and maintenance

If and when

Technical Data

3. Carefully remove the cover ① towards the lever → Fig. 153 A.
4. Pull the release ③ in the connector ② in the direction of the arrow → Fig. 153 B. Use the screwdriver in the vehicle tool kit.
5. Press position ④ and remove the connector ② → Fig. 153 B.
6. Unscrew the wing nut ⑤ → Fig. 153 B.
7. Remove the tail light from the bodywork by carefully pulling backwards.
8. Disassemble the tail light unit and place it on a flat, clean surface.

To change the bulb

9. Unlock the bulb holder locking tab (arrow) → Fig. 154 C and remove the bulb holder from the tail light.
10. Replace the faulty bulb by a new identical bulb → Fig. 154 D.
11. Place the lamp holder in the tail light unit. The attachment tabs (arrow) should audibly click into place → Fig. 154 C.

Assembling the tail light units

12. Carefully insert the tail light unit into the opening in the bodywork.
13. Support the tail light with one hand in the assembly position and securely screw the wing nut with the other ⑤ → Fig. 153 B.
14. Ensure that the tail light unit has been correctly fitted and is firmly secured.
15. Insert the connector ② into the bulb holder and press the lock ③ on the connector in the opposite direction to the arrow → Fig. 153 B.
16. Insert the cover. The cover should lock into place.
17. Close the rear lid → page 40.

Changing the number plate light

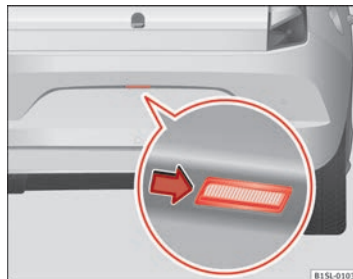


Fig. 155 On the rear bumper: Remove number plate light



Fig. 156 Number plate light: Remove the lamp holder

Only carry out the operations in the sequence indicated:

1. Always take the checklist into account and take the necessary actions ⇒ page 265.
2. With one hand, press on the number plate light from left to right and remove it from the bumper ⇒ Fig. 155.
3. Detach the number plate light carefully from the bumper.
4. Turn the bulb holder with the bulb **anticlockwise** and remove it in the direction of the arrow ⇒ Fig. 156.
5. Replace the faulty bulb by a new identical bulb.
6. Place the bulb holder in the number plate light and press in the opposite direction to the arrow as far as possible ⇒ Fig. 156.
7. Insert the number plate light carefully into the left edge of the opening on the bumper. During this process, check that the assembly direction of the number plate light is correct, i.e. the spring must be on the right.
8. Insert the number plate light into the bumper until it audibly clicks into place. ■

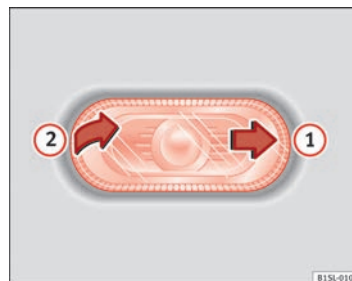
Changing the side turn signal bulb

Fig. 157 Removing the side turn signal



Fig. 158 Side turn signal: Changing the bulbs

Only carry out the operations in the sequence indicated:

1. Always take the checklist into account and take the necessary actions ⇒ page 265.
2. With one hand move the side turn signal backwards ⇒ Fig. 157 ①. ▶

Only carry out the operations in the sequence indicated:

3. Remove the side turn signal from the chassis by leverage ②.
4. Remove the bulb holder with the bulb in the direction of the arrow
⇒ Fig. 158 ①.
5. Remove the bulb holder bulb in a straight direction.
6. Replace the faulty bulb by a new identical bulb.
7. Install the lamp holder.
8. Place the side turn signal on the chassis on the side situated towards the rear of the vehicle until the spring clicks into the other side of the side turn signal. ■

Starting assistance

Introduction

If the engine fails to start because of a discharged battery, the battery of another vehicle can be used to start the engine. Before starting, check the magic eye on the battery ⇒ page 193.

For starting assistance, jump lead cables conforming to the standard DIN 72553 are required (see the cable manufacturer instructions). The cable section in vehicles with petrol engine must be at least 25 mm².

Additional information and warnings:

- Working in the engine compartment ⇒ page 180
- Vehicle battery ⇒ page 193

WARNING

Incorrect use of jump leads and incorrectly jump starting could cause the battery to explode resulting in serious injury. Please observe the following rules to minimise the risk of a battery explosion:

- All work involving the vehicle battery and electrical system can cause corrosion, fire and serious electric shocks. Always read and take into account the safety warnings and standards before beginning work on the battery ⇒ page 193, Vehicle battery.
- The battery providing current must have the same voltage (12V) and approximately the same capacity (see markings on battery) as the flat battery.
- Never charge a frozen or recently thawed battery. A flat battery can also freeze at temperatures close to 0 °C (+32 °F).
- If a battery is frozen and/or has been frozen then it must be replaced.

WARNING (Continued)

• A highly explosive mixture of gases is released when the battery is being charged. Always keep lit cigarettes, open flames, sparks and fire far from the battery. Never use a mobile telephone when connecting and removing the jump leads.

- Charge the battery only in well ventilated areas given that when the battery is charged by outside assistance, it creates a mix of highly explosive gases.
- Jump leads should never enter into contact with moving parts in the engine compartment.
- Never switch the positive and negative poles or connect the jump leads incorrectly.
- Note the Instruction Manual provided by the manufacturer of the jump leads.

CAUTION

To avoid considerable damage to the vehicle electrical system, note the following carefully:

- If the jump leads are incorrectly connected, this could result in a short circuit.
- The vehicles must not touch each other, otherwise electricity could flow as soon as the positive terminals are connected.

How to jump start: description

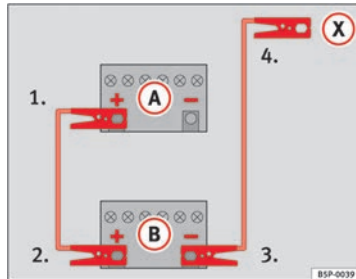


Fig. 159 Diagram of connections for vehicles without Start-Stop system

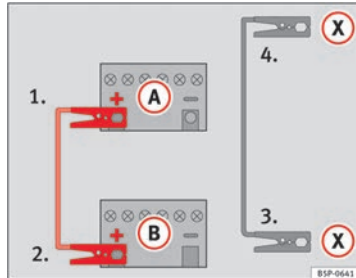


Fig. 160 Diagram of connections for vehicles with Start-Stop system

Jump lead terminal connections

1. Switch off the ignition of both vehicles \Rightarrow Δ .
2. For vehicles without Start-Stop system:

- Connect one end of the *red* jump lead to the positive \oplus terminal of the vehicle with the flat battery $\textcircled{A} \Rightarrow$ Fig. 159.
- Connect the other end of the *red* jump lead to the positive terminal \oplus in the vehicle providing assistance \textcircled{B} .
- Connect one end of the *black* jump lead to the negative terminal \ominus of the vehicle providing assistance $\textcircled{B} \Rightarrow$ Fig. 159.
- Connect the other end of the *black* jump lead \textcircled{X} to a solid metal component bolted to the engine block or to the engine block itself of the vehicle with the flat battery. However, connect it to a point as far as possible from the battery \textcircled{A} .

3. For vehicles with Start-Stop system:

- Connect one end of the *red* jump lead to the positive \oplus terminal of the vehicle with the flat battery $\textcircled{A} \Rightarrow$ Fig. 160.
 - Connect the other end of the *red* jump lead to the positive terminal \oplus in the vehicle providing assistance \textcircled{B} .
 - Connect one end of the *black* jump lead \textcircled{X} to a suitable ground terminal, a solid piece of metal in the engine block, or to the engine block \Rightarrow Fig. 160.
 - Connect the other end of the *black* jump lead \textcircled{X} to a solid metal component bolted to the engine block or to the engine block itself of the vehicle with the flat battery. However, connect it to a point as far as possible from the battery \textcircled{A} .
4. Position the leads in such a way that they cannot come into contact with any moving parts in the engine compartment. \blacktriangleright

Starting

- Start the engine of the vehicle with the boosting battery and let it run at idling speed.
- Start the engine of the vehicle with the flat battery and wait one or two minutes until the engine is “running”.

Removing the jump leads

- Before you remove the jump leads, switch off the headlights (if they are switched on).
- When the engine is running, disconnect the leads in reverse order to the details given above.

Connect the battery clamps so they have good metal-to-metal contact with the battery terminals.

If the engine fails to start, switch off the starter after about 10 seconds and try again after about half a minute.

WARNING

- Please note the safety warnings referring to working in the engine compartment ⇒ page 182.
- The battery providing assistance must have the same voltage as the flat battery (12V) and approximately the same capacity (see imprint on battery). Failure to comply could result in an explosion.
- Never use jump leads when one of the batteries is frozen. Danger of explosion! Even after the battery has thawed, battery acid could leak and cause chemical burns. If a battery freezes, it should be replaced.
- Keep sparks, flames and lighted cigarettes away from batteries, danger of explosion. Failure to comply could result in an explosion.

WARNING (Continued)

- Observe the instructions provided by the manufacturer of the jump leads.
 - Do not connect the negative cable from the other vehicle directly to the negative terminal of the flat battery. The gas emitted from the battery could be ignited by sparks. Danger of explosion.
 - Do not attach the negative cable from the other vehicle to parts of the fuel system or to the brake line.
 - The non-insulated parts of the battery clamps must not be allowed to touch. The jump lead attached to the positive battery terminal must not touch metal parts of the vehicle, this can cause a short circuit.
 - Position the leads in such a way that they cannot come into contact with any moving parts in the engine compartment.
 - Do not bend over the batteries. This could result in chemical burns.



Note

The vehicles must not touch each other, otherwise electricity could flow as soon as the positive terminals are connected.

Towing and tow starting

Introduction

When towing or tow starting, respect the legal requirements.

For technical reasons, it is not possible to tow a vehicle if the battery is flat.

Additional information and warnings:

- Exterior detail ⇒ page 6
- Electronic power control and exhaust gases purification system ⇒ page 236



WARNING

A vehicle with a flat battery should never be towed.

- **Never remove the key from the ignition lock. Otherwise, the steering wheel lock could suddenly lock. Then the vehicle will be uncontrollable. You may lose control of the vehicle and there is a risk of serious accident.**



WARNING

When towing the vehicle, the handling and braking efficiency change considerably. Please observe the following instructions to minimise the risk of serious accidents and injury:

- **As the driver of the vehicle being towed:**
 - The brake must be depressed much harder as the brake servo does not operate. Always remain aware to avoid collision with the towing vehicle.
 - More strength is required at the steering wheel as the power steering does not operate when the engine is switched off.
- **As the driver of the towing vehicle:**
 - Accelerate gently and carefully.
 - Avoid sudden braking and manoeuvres.
 - Brake well in advance than usual and brake gently.



CAUTION

- Carefully fit and remove the towing ring and its cover to avoid damage to the vehicle (for example, paintwork).
- When towing, fuel could enter the catalytic converter and cause damage!



Note

Fitting a towline anchorage to the rear bumper is not possible. The vehicle is not suitable for towing other vehicles. ■

Instructions for tow starting

In general, the vehicle should not be started by towing. Jump-starting is much more preferable ⇒ page 273.

For technical reasons, the following vehicles can **not** be tow started:

- Vehicles with an automatic gearbox.
- If the vehicle battery is flat, it is possible that the engine control unit does not operate correctly.

However, if your vehicle must absolutely be tow-started (manual gearbox):

- Engage the 2nd or 3rd gear.
- Keep the clutch pressed down.
- Switch on the ignition and the hazard warning lights.
- Release the clutch when both vehicles are moving.
- As soon as the engine starts, press the clutch and move the gear lever into neutral. This helps to prevent a collision with the towing vehicle.



CAUTION

When tow-starting, fuel could enter the catalytic converter and damage it. ■

Notes on towing

Tow rope or tow bar

When towing, the tow bar is the safest and vehicle friendly way. You should only use a tow rope if you do not have a tow bar.

A tow rope should be slightly elastic to avoid damage to both vehicles. It is advisable to use a tow rope made of synthetic fibre or similarly elastic material.

Only secure the tow rope or tow bar to the tow ring or specially designed fitting.

Towing vehicles with an automatic gearbox

Note the following for a towed vehicle:

- Make sure the gear selector lever is in the **N** position.
- Do not drive faster than 50 km/h (30 mph) when towing a vehicle.
- Do not tow further than 50 km (30 miles).
- If a breakdown truck is used, the vehicle must be towed with the front wheels raised.

Situations in which the vehicle should not be towed

In the following cases, the vehicle should not be towed but transported on a trailer or special vehicle:

- If the vehicle gearbox does not contain lubricant due to a fault.
- If the battery is flat as the steering cannot be unlocked, as a result, the electronic steering lock and electronic parking brake cannot be disengaged.
- If the vehicle to be towed has an automatic gearbox and the distance to be covered is greater than 50 km (30 miles).



Note

The vehicle can only be towed if the steering lock electronic gearbox lock is deactivated. If the vehicle has no power supply or there is an electric system fault, the engine must be started using jump leads to deactivate the steering column electronic gearbox lock. ■

Fitting the front tow ring

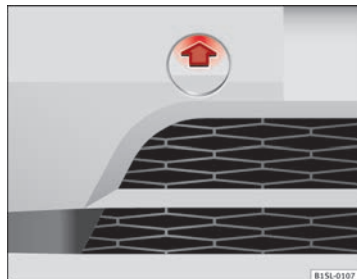


Fig. 161 On the right-hand side of the front bumper: Remove the cover



Fig. 162 On the right-hand side of the front bumper: Screw in the towing ring

The location for the removable tow ring is on the right-hand side of the front bumper behind a cover ⇒ Fig. 161.

The towing eye should always be kept in the vehicle.

Note the instructions for towing ⇒ page 277.

To fit the tow ring

- Take the tow ring from the vehicle tool kit in the luggage compartment ⇒ page 246.
- Press the upper part of the cover ⇒ Fig. 161 (arrow) to disengage and release the cover.
- Remove the cover and leave it hanging from the vehicle.
- Screw in the tow ring into its housing **anticlockwise** as far as it will go ⇒ Fig. 162 ⇒ ⓐ. Use a suitable tool to firmly tighten the tow ring in its location.
- After towing, remove the tow ring by turning it **clockwise**.
- Place the cover upper tab on the opening of the bumper and carefully hold the lower tab on the edge of the opening. If necessary, press the lower tab from below.
- Press the lower area of the cover until the lower tab engages in the bumper.



CAUTION

The tow ring must always be completely and firmly tightened. Otherwise, it could be released while towing and tow-starting. ■

Towing advice

Towing requires some experience, especially when using a tow rope. Both drivers should be familiar with the technique required for towing. For this reason, inexperienced drivers should abstain.

While driving, avoid excessive traction forces and jerking. When towing on an unpaved road, there is always a risk of overloading and damaging the anchorage points. ►

If the vehicle is towed, with the hazard warning lights on and the ignition switched on, the turn signal may be used to indicate changes of direction. Simply operate the turn signals lever as usual. Meanwhile, the hazard warning lights will go off. When the turn signal lever is returned to the rest position, the hazard warning lights will be turned on automatically.

Notes for the driver of the towed vehicle

- Keep the ignition running to prevent the steering wheel from locking and also to allow the use of the turn signals, horn, windscreen wipers and washers.
- As the power assisted steering does not work if the engine is not running, you will need more strength to steer than normally.
- The brake must be depressed must harder as the brake servo does not operate. Avoid hitting the towing vehicle.
- Note the instructions and information contained in the instruction manual for the vehicle to be towed.

Notes for the driver of the towing vehicle

- Accelerate gently and carefully. Avoid sudden manoeuvres.
- Brake well in advance than usual and brake gently.
- Note the instructions and information contained in the instruction manual for the vehicle to be towed. ■

Vehicle diagram

Prior to a journey...

While driving

Care, cleaning and maintenance

If and when

Technical Data

Technical Data

Description of specifications

Technical specifications

Introduction

The information in your vehicle's official documentation always take precedence over the information in the current instruction manual.

The Maintenance Programme vehicle data or the official vehicle documents show which engine is installed in the vehicle.

All the technical data provided in this documentation is applicable to the basic model. The figures indicated here may be different depending on the additional equipment added to the vehicle or the vehicle version, in addition to special vehicles for other markets.

Additional information and warnings:

- Transporting ⇒ page 97
- Ecological driving ⇒ page 144
- Fuel ⇒ page 177
- Engine oil ⇒ page 185
- Engine coolant ⇒ page 189
- Wheels and tyres ⇒ page 210
- Notes for the user ⇒ page 233



WARNING

Failure to observe requirements for weight, loads, dimensions and maximum speed may lead to severe accident.

Vehicle identification data

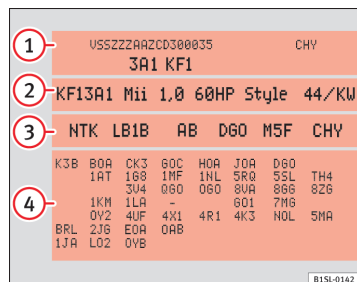


Fig. 163 TO: Vehicle data label: in the example, engine with code CBFA
①. B: Identification plate



Fig. 164 Vehicle identification number

Vehicle identification number

The vehicle identification number (chassis number) can be read from outside the vehicle through a viewer in the windscreen ⇒ Fig. 164. This viewer is located in the lower part of the windscreen. The vehicle identification

number (chassis number) is also stamped on the right water drain channel. The water drain channel is located between the suspension tower and the wing. Open the bonnet to read the vehicle identification number Δ .

Vehicle data plate

The vehicle data label ⇒ Fig. 163 is at the front of the spare wheel well. It contains the following data:

- ① Vehicle identification number (chassis number)
- ② Vehicle type, engine power, gearbox type
- ③ Engine and gearbox code, paint number, interior equipment. In the example, the engine has the code "CBFA" ⇒ Fig. 163.
- ④ Optional extras, PR numbers

These data are also provided in the Maintenance Programme. ■

Specific vehicle weight information

The instructions in the official vehicle documents take precedence. All the technical data provided in this documentation is applicable to the basic model. The vehicle data label in the Maintenance Programme or the vehicle documents show which engine is installed in your vehicle.

The figures may be different depending whether additional equipment is fitted, for different models and for special vehicles.

Kerb weight values shown in the following table apply for a vehicle with driver (75 kg), liquids including a fuel tank 90% full, in addition to tools and a spare wheel ⇒ Δ . The kerb weight indicated increases with optional equipment and retrofitting of accessories, while proportionally reducing carrying capacity.

The load is equivalent to the following weights: ▶

Vehicle diagram

Prior to a journey...

While driving

Care, cleaning and maintenance

If and when

Technical Data

- Passengers.
- Total equipment.
- Roof load, included in the carrier.

**WARNING**

Exceeding the maximum authorised weight and the load on the axles could cause damage to the vehicle, accidents and serious injuries.

- The real load on the axles should never exceed the maximum permitted.
- The load and its distribution in the vehicle have effects on the vehicle handling and the braking ability. Always drive at a suitable speed.

**CAUTION**

Distribute the load as uniformly and as low down on the vehicle as possible. When transporting heavy objects in the luggage compartment, these should be placed as far forward as possible or over the rear axle to have as little influence on handling as possible.

Information on fuel consumption

The consumption and emission values indicated do not refer to one specific vehicle. They are only to be used to compare the values of the different vehicle versions. The fuel consumption and CO₂ emissions of a vehicle not only depend on the effective use of fuel. They also depend on your driving style and other non-technical factors.

Calculation of fuel consumption

Fuel consumption and emission values are determined according to the current version of the 715/2007/EC or 80/1268/EEC regulation and are valid for the vehicle kerb weight. The specifications do **not** refer to an individual

vehicle. To measure the fuel consumption, two measuring cycles are carried out on a rolling road test bed. The test criteria are as follows:

Urban cycle	Measurement of the urban cycle starts with an engine cold start. City driving is then simulated at between 0 and 50 km/h (0 and 31 mph).
Road cycle	In the road cycle simulation, the vehicle undergoes frequent acceleration and braking in all gears, as in normal everyday driving. The road speed ranges from 0 to 120 km/h (0 and 75 mph).
Combined	The average combined consumption is calculated with a weighting of around 37 % for the urban cycle and 63 % for the road cycle.
CO₂ emissions of the combination	The exhaust gases are collected during both driving cycles to calculate carbon dioxide emissions (urban and road). The gas composition is then analysed to evaluate the CO ₂ content and other emissions.

**Note**

The kerb weight may vary according to the vehicle equipment. This could raise consumption and the CO₂ emissions slightly.

**Note**

In practice, consumption values could be different to the values calculated based on the 715/2007/EC or 80/1268/EEC regulations.

Engine specifications

Petrol engine 1.0 44 kW (60 PS)

Engine specifications

Power output in kW (PS)	rpm	44 (60)/ 5000-6000
Maximum torque	in Nm at rpm	95/ 3000-4300
No. of cylinders/capacity	in cm ³	3/ 999
Fuel		95 super RON ^{a)}

a) Research Octane Number = Anti-detonation rating of the petrol.

Performance

Maximum speed	in km/h (mph)	160
Acceleration from 0-80 km/h (0-50 mph)	in sec.	9,1
Acceleration from 0-100 km/h (0-60 mph)	in sec.	14,4

Consumption (l/100 km) / CO₂ emissions (g/km)

Urban cycle	5,6/130
Extra-urban cycle	3,9/91
Combined	4,5/105

Weights

Gross vehicle weight	in kg	1290
Weight in running order (with driver)	in kg	929
Gross front axle weight	in kg	551
Gross rear axle weight	in kg	378
Permitted roof load	in kg	50

Petrol engine 1.0 44 kW (60 PS) Ecomotive

Engine specifications

Power output in kW (PS)	rpm	44 (60)/5000
Maximum torque	in Nm at rpm	92/3000
No. of cylinders/capacity	in cm ³	3/999
Fuel		95 super RON ^{a)}

^{a)} Research Octane Number = Anti-detonation rating of the petrol.

Performance

Maximum speed	in km/h (mph)	161
Acceleration from 0-80 km/h (0-50 mph)	in sec.	9,1
Acceleration from 0-100 km/h (0-60 mph)	in sec.	14,4

Consumption (l/100 km) / CO₂ emissions (g/km)

Urban cycle		5 / 116
Extra-urban cycle		3,6 / 84
Combined		4,1 / 96

Weights

Gross vehicle weight	in kg	1290
Weight in running order (with driver)	in kg	940
Gross front axle weight	in kg	561
Gross rear axle weight	in kg	379
Permitted roof load	in kg	50

Petrol engine 1.0 44 kW (60 PS) Automatic

Engine specifications

Power output in kW (PS)	rpm	44 (60) / 5500
Maximum torque	in Nm at rpm	92 / 3000-4300
No. of cylinders/capacity	in cm ³	3 / 999
Fuel		Super 95 RON ^{a)}

a) Research Octane Number = Anti-detonation rating of the petrol.

Performance

Maximum speed	in km/h (mph)	160
Acceleration from 0-80 km/h (0-50 mph)	in sec.	9,4
Acceleration from 0-100 km/h (0-60 mph)	in sec.	15,3

Consumption (l/100 km) / CO₂ emissions (g/km)

Urban cycle	5,3/123
Extra-urban cycle	3,9/91
Combined	4,4/103

Weights

Gross vehicle weight	in kg	1290
Weight in running order (with driver)	in kg	932
Gross front axle weight	in kg	554
Gross rear axle weight	in kg	378
Permitted roof load	in kg	50

Vehicle diagram

Prior to a journey...

While driving

Care, cleaning and maintenance

If and when

Technical Data

Petrol engine 1.0 55 kW (75 PS)

Engine specifications

Power output in kW (PS)	rpm	55 (75)/ 6200
Maximum torque	in Nm at rpm	95/ 3000-4300
No. of cylinders/capacity	in cm ³	3/ 999
Fuel		95 super RON ^{a)}

^{a)} Research Octane Number = Anti-detonation rating of the petrol.

Performance

Maximum speed	in km/h (mph)	171
Acceleration from 0-80 km/h (0-50 mph)	in sec.	8,3
Acceleration from 0-100 km/h (0-60 mph)	in sec.	13,2

Consumption (l/100 km) / CO₂ emissions (g/km)

Urban cycle	5,9/137
Extra-urban cycle	4/93
Combined	4,7/108

Weights

Gross vehicle weight	in kg	1290
Weight in running order (with driver)	in kg	929
Gross front axle weight	in kg	551
Gross rear axle weight	in kg	378
Permitted roof load	in kg	50

Petrol engine 1.0 55 kW (75 PS) Start-Stop

Engine specifications

Power output in kW (PS)	rpm	55 (75)/6200
Maximum torque	in Nm at rpm	95/3000-4300
No. of cylinders/capacity	in cm ³	3/999
Fuel		95 super RON ^{a)}

a) Research Octane Number = Anti-detonation rating of the petrol.

Performance

Maximum speed	in km/h (mph)	172
Acceleration from 0-80 km/h (0-50 mph)	in sec.	8,3
Acceleration from 0-100 km/h (0-60 mph)	in sec.	13,2

Consumption (l/100 km) / CO₂ emissions (g/km)

Urban cycle	5,1 / 118
Extra-urban cycle	3,7 / 86
Combined	4,2 / 98

Weights

Gross vehicle weight	in kg	1290
Weight in running order (with driver)	in kg	940
Gross front axle weight	in kg	561
Gross rear axle weight	in kg	379
Permitted roof load	in kg	50

Vehicle diagram

Prior to a journey...

While driving

Care, cleaning and maintenance

If and when

Technical Data

Petrol engine 1.0 55 kW (75 PS) Automatic

Engine specifications

Power output in kW (PS)	rpm	55 (75)/ 6200
Maximum torque	in Nm at rpm	95/ 3000-4300
No. of cylinders/capacity	in cm ³	3/ 999
Fuel		Super 95 RON ^{a)}

^{a)} Research Octane Number = Anti-detonation rating of the petrol.

Performance

Maximum speed	in km/h (mph)	171
Acceleration from 0-80 km/h (0-50 mph)	in sec.	9
Acceleration from 0-100 km/h (0-60 mph)	in sec.	13,9

Consumption (l/100 km) / CO₂ emissions (g/km)

Urban cycle	5,5/127
Extra-urban cycle	4/94
Combined	4,5/105

Weights

Gross vehicle weight	in kg	1290
Weight in running order (with driver)	in kg	932
Gross front axle weight	in kg	554
Gross rear axle weight	in kg	378
Permitted roof load	in kg	50

Petrol / gas engine 1.0 50 kW (68 PS)

Engine specifications

Power output in kW (PS)	rpm	50 (68) / 6200
Maximum torque	in Nm at rpm	90 / 3000
No. of cylinders/capacity	in cm ³	3 / 999
Fuel		CNG / Super 95 RON ^{a)}

a) Research Octane Number = Anti-detonation rating of the petrol.

Performance

Maximum speed	in km/h (mph)	164
Acceleration from 0-80 km/h (0-50 mph)	in sec.	9,8
Acceleration from 0-100 km/h (0-60 mph)	in sec.	15,8

Consumption (l/100 km) / CO₂ emissions (g/km)

Urban cycle	-
Extra-urban cycle	-
Combined	2,9/79

Weights

Gross vehicle weight	in kg	1370
Weight in running order (with driver)	in kg	1031
Gross front axle weight	in kg	570
Gross rear axle weight	in kg	461
Permitted roof load	in kg	50

Dimensions

Longitude	3557 mm
Width	1641 - 1645 mm
Height, unladen	1478 - 1489 mm
Wheelbase	2420 mm
Turning circle diameter ^{a)}	approx. 9.8 m
Front track width ^{a)}	1412 - 1428 mm
Rear track width ^{a)}	1408 - 1424 mm
Ground clearance with maximum authorised load	109 mm

^{a)} Depending on the dimensions of the wheel trims and tyres, there may be variations.



CAUTION

- Special care should be taken when parking in areas with high kerbs or fixed barriers. Objects protruding from the ground may damage the bumper or other parts of the vehicle during manoeuvres.
- Special attention is required when driving through entrances, over ramps, kerbs or other objects. The vehicle underbody, bumpers, mudguards and running gear, and the engine and exhaust system could be damaged as you drive over these objects. ■

Capacities

	Fuel tank capacity
Petrol engines	Around 35.0 l, of which approximately 4.0 are the reserve. ■

Index

A

- Abroad
 - Extended stay abroad with your vehicle . . . 234
 - Sale of vehicle 234
- ABS
 - See "Braking assist systems" 140
- Accessories 222, 223
- Additional equipment 224
- Adjust
 - Headlight range 88
- Adjustment
 - Correct sitting position 50
 - Front seat 51
 - rear head restraints 52
 - Steering wheel 53
- Aerial 234
- Airbag system 67
 - Cleaning dash panel 208
 - Control lamp 69
 - Deactivating the front passenger airbag . . . 73
 - Deactivating using the key switch 73
 - Description 70
 - Differences between front passenger airbag systems 69
 - Faults 225
 - Front airbags 72
 - Function 70
 - Locking the vehicle after airbag deployment 33
 - Repairs 225
 - Side airbags 75
 - Use of child seats 73
 - Vehicle care 208
- Air conditioner
 - Air recirculation 169
 - Air vents 169
 - Faults 168
 - set 167
 - Things to note 168
 - User instructions 167
- Air conditioning system 164
 - Controls 166
- Air recirculation 169
 - How it works 169
 - switch off 169
 - temporarily switch off 169
- Air vents 169
- Alternator 194
- Aluminium care 202
- Anodized surfaces 202
- Anti-lock brake system (ABS) 140
- Anti-puncture kit 256
- Anti-theft locking bolts 250
- Anti-theft wheel locking bolts 251
- Antifreeze 190
- Antitheft bolts 247
- Ashtray 115
- ASR
 - see Brake assist systems 140
- Assistance systems
 - Brake assist system (BAS) 140
 - Cruise control system (CCS) 152
 - Electronic differential lock system (EDL) . . 140
 - electronic stability control (ESC) 139
 - Hill hold 160
 - Optical parking system (OPS) 150
 - Parking aid 150
 - Parking distance warning system 150
 - Safety Assist (City Safety Assist function) . 155
 - Traction control system (ASR) 140
 - Traction Control (TC) 140
- Assisted braking systems 139
- Assist systems
 - Anti-lock brake system (ABS) 140
- Audible warnings
 - Control and warning lamps 15
 - Lights 86
 - Seat belt not fastened 58
 - Speed 23
 - Automatic belt retainer 65
- Automatic car wash 198
- Automatic consumer disconnection 196
- automatic gearbox 124
- Automatic gearbox 129
 - driving 131
 - Ignition key lock 121
 - Kickdown 131

malfunction	132
starting on a slope	131
stopping on a slope	131
Axle loads	281

B

BAS	
see Brake assist systems	140
Battery	
Change in the vehicle key	31
discharge	33
Discharging	241
See Vehicle battery	193
Battery acid	195
Before consulting a specialised workshop ..	238
Belt tension device	65
Disposal	65
Service and disposal	65
Belt tension limiter	65
Bench	101
Bonnet	
Closing	183
Opening	183
Bottle capacity	
Windscreen washer water bottle	94
Brake	134
Brake servo	138
Brake assist system (BAS)	140
Brake fluid	141
Specification	141

Brakes	
Assisted braking systems	139
Brake fluid	141
Brake fluid level	142
Brake pads	137
Changing the brake fluid	142
Control lamp	135
Emergency brake indicator in case of sud-	
den braking	241
Handbrake	136
Running-in brake pads	137
Warning lamp	135
Brake servo	138, 139
Brake system	
Malfunction	138
Brake systems	139
Breakdown	
Securing the vehicle	240
Bulb fault	
See changing bulbs	264
C	
Capacities	
Fuel tank	290
Care	
See "Care of your vehicle"	197
Vehicle interior	205
Care of your vehicle	
Exterior	197
Caring for paintwork	202
Carrier system	104

Catalytic converter	237
Control lamp	236
Malfunctions	236
CCS	152
central locking	
Deadlock	37
Central locking	33
Central locking button	36
locking and unlocking from the exterior ..	34
locking and unlocking from the inside ..	36
Central locking system	
After airbag deployment	33
Description	33
Opening doors individually	33
Centre console	12, 13
Bottom part	13
Top part	12
Changing	
Windscreen wiper blades	201
Changing a wheel	250
Changing a wheel	255
Preparations	251
Raising the vehicle	253
Wheel bolts	251
Changing bulbs	264
Checklist	265
Front bumper	267
Initial operations	265
in the headlights	266
Number plate light	270
Rear lights	269
Sea changing bulbs	264

- Changing gear 124
 - Automatic gearbox 129
 - Engaging gears (automatic gearbox) 129
 - Engaging gears (manual gearbox) 128
 - Manual gearbox 128
 - Warning and control lamps 125
 - with Tiptronic 130
- Changing gears
 - Gear recommendation 132
- Changing the bulbs
 - Side turn signal 271
- Changing the wheel
 - After changing the wheel 255
- Chassis number 281
- Checking
 - Tyre pressures 215
- Checking the oil level 186
- Checklist
 - Before working in the engine compart-
ment 182
 - Changing bulbs 265
 - In case of an emergency 240
- Checklist
 - Journey preparations 25
 - Preparations for changing a wheel 251
 - Raising the vehicle with the jack 254
- Checklist
 - Refuelling precautions 176
- Checklist
 - Safe driving 25
- Cleaning
 - dash panel 208
 - Engine compartment 204
- Checklist
 - Seat belts 61
 - Tire Mobility Set 258
 - Transporting children in the vehicle 77
- Check list
 - Upholstery 206
- Child safety seat
 - Securing with seat belt 80
- Child seat
 - ISOFIX child seat on rear seats 80
 - Mounting child seats 78
 - Mounting systems 79
 - On rear seats 80
 - On the front passenger seat 79
 - Regulations 77
 - Securing using a Top Tether retaining strap 83
 - Securing using ISOFIX 81
 - Securing using LATCH 81
 - Transporting children in the vehicle 77
 - Weight categories 77
- Child seats 76
 - Disabling the front passenger airbag 73
- Chromework care 202
- Cigarette lighter 115
- City Safety Assist function 155
 - Control lamp 156
 - Function 158
 - Sensor 157
 - Special driving situations 159
 - Warning lamp 156
- Cleaning
 - dash panel 208
 - Engine compartment 204
- Seat belts 208
- See "Care of your vehicle" 197
- wheel rims 203
- Windscreen wiper blades 201
- Clock 18
- Close
 - Sliding/tilting electric panoramic sunroof . 44
- Closing
 - Doors 38
 - from the exterior 34
 - from the inside 36
 - Rear lid 41
 - Windows 43
- Coat hooks 112
- Code number 247
- Collection of end-of-life vehicles 235
- Compartments
 - Centre console 109
 - Glove compartment 110, 111
 - Other storage compartments 112
 - Passenger side 110, 111
 - Sunglasses storage compartment 110
- Components 224
- Conformity certification 234
- Consumer disconnection 196
- Consumption
 - How it is determined 282
 - Information 282
- control lamp
 - on the driver door 37
 - Vehicle key 30

- Control lamp
- Airbag system 69
 - Brake pad wear warning 135
 - Brake system 135
 - Catalytic converter 236
 - City Safety Assist function 156
 - Cruise control system (CCS) 152
 - Emission control system 236
 - Engine coolant 189
 - Engine management 236
 - Engine oil sensor 185
 - ESC 135
 - Fuel level 172
 - Hill hold 160
 - Overview 15
 - Steering column lock 147
- Controlling function
- Electric exterior mirrors 96
- Control units 226
- Reprogramming 227
- Convenience functions
- Reprogramming 227
- Coolant
- See engine coolant 189
- Crossing a river
- Salt water 27
- Cruise control system 152
- Cruise control system (CCS)
- Control lamp 152
 - Operations 153
- D**
- Damaged tyres 216
- Dangers of not using the seat belt 60
- Dash panel 10
- Airbag system 67, 208
- Data link connector (DLC) 227
- Data registry 226
- Data storage during the journey 226
- Data stored by the control units 226
- Daytime driving light 87
- De-icing the door lock cylinder 203
- De-icing the locks 203
- Deadlock
- Deadlock 37
 - SAFELOCK 37
- Deadlock (immobilizer) 123
- Detail
- passenger seat 14
- Diagnostics connection 227
- Differential lock
- See "Brake assist systems" 140
- Digital clock 18
- Dimensions 290
- Dipped beam headlights 86
- Dipstick 186
- Display 19
- Instrument panel 19
- Disposal
- Airbag system 235
 - Belt tension device 65
 - End-of-life vehicle 235
- Door handle
- exterior 6
- Door release lever
- interior 9
- Doors 38
- Childproof locks 38
 - Emergency locking and unlocking 243
- Drink holders 113
- Centre console 114
- Drinks bottles
- see Drink holders 113
- Driver door
- Overview 9
- Driver position 10
- Driving
- Check list 26
 - Data storage 226
 - Driving abroad 26
 - Driving through water 27
 - Driving with an automatic gearbox 131
 - Ecological 144
 - Economic 144
 - Fuel gauge 172
 - Fuel level to low 173
 - Journey preparations 25
 - Parking downhill 137
 - Parking uphill 137
 - Protection of the undercarriage 25
 - starting on a slope 131
 - stopping on a slope 131
 - Tips 25
 - Towing 278

- Driving abroad
 - Check list 26
 - Headlights 87
 - Driving advice
 - Spare wheel 217
 - Temporary spare wheel 217
 - Driving in winter
 - Fuel consumption 146
 - Snow chains 220
 - Tread depth 216
 - Tyre pressures 214
 - Windscreen washer bottle 200
 - Driving through water 27
 - Driving tips
 - Driving a loaded vehicle 97
 - Dust filter 164
- E**
- Ecological driving 144
 - Economic driving 144
 - EDL
 - See "Brake assist systems" 140
 - Electrical components 117, 241
 - Electrical consumers 118
 - Electrical power socket 117
 - Electric windows
 - Buttons 43
 - Closing 43
 - Opening 43
 - see Windows 43
 - Electronic differential lock system (EDL) 140
 - Electronic immobilizer 122
 - Electronic Stability Control (ESC) 139
 - Emergency brake indicator 241
 - Emergency locking and unlocking 243
 - Driver door 243
 - Passenger door 244
 - Rear lid 244
 - Emission control system
 - Control lamp 236
 - Engaging gears
 - Automatic gearbox 129
 - Manual gearbox 128
 - Engine
 - Noises 122
 - Running-in 223
 - Engine and ignition 119
 - 12 Volt sockets 117
 - Ignition lock 120
 - Immobilizer 122
 - Starting the engine 121
 - Stopping the engine 122
 - Unauthorised vehicle key 120
 - Engine compartment 180
 - Engine coolant 189
 - Engine oil 185
 - Preparation 182
 - Vehicle battery 193
 - Water box 204
 - Engine coolant 189
 - Checking the level 191
 - Filler mouth 191
 - G 12 plus-plus 190
 - G 13 190
 - Refilling 191
 - Specifications 190
 - Temperature gauge 189
 - Warning lamp 189
 - Engine management 236
 - Control lamp 236
 - Engine oil 185
 - changing 188
 - Checking the oil level 186
 - Consumption 187
 - Dipstick 186
 - Filler mouth 186
 - Indicator 185
 - Specifications 185
 - Topping up 186
 - Errors 238
 - ESC 139
 - see Electronic Stability Control (ESC) 139
 - Event Data Recorder 227
 - Exhaust gas purification system 236
 - Exterior aerial 226
 - Exterior mirrors 95
 - Controlling function 96
 - folding 95
 - Vehicle care 200
 - Exterior views 6
- F**
- FAQs 238
 - Fault
 - Parking distance warning system 150

- Fault finding 238
- Fault memory
 Connector 227
- Faults 238
- Air conditioner 168
- Fire extinguisher 242
- First-aid kit
 Storage 242
- First aid kit 242
- see First aid kit 242
- Floor mats 127
- Fluids 224
- Fog lights 86
- Frequently asked questions 238
- Front airbags
 See "Airbag system" 72
- Front passenger airbag
 Deactivating using the key switch 73
- See "Airbag system" 67
- Fuel 177
- Information on consumption 282
- Petrol 177
- Type of fuel 177
- Fuel consumption
 Economic driving 144
- ¿Why does it increase? 236
- Fuel gauge 172
- Control lamp 172
- Fuel 172
- Refuelling 172
- Fuel tank flap
 close 174
- open 174
- Petrol 174
- Fuses 261
- Fuse box 262
- Identifying blown fuses 263
- Identifying by colours 262
- Preparation before replacing 263
- Replacement 263
- G**
- Glove compartment
 see Compartments 110, 111
- H**
- Handbrake 136
- Hazard warning lights system 240
- Headlamp range adjustment 11
- Headlight range control 88
- Headlights
 Driving abroad 87
- Headlight washers 92
- Heated rear window 167
- Heated seats 55
- Heating and ventilation system
 Controls 166
- see also Air conditioning system 164
- High pressure cleaning apparatus 199
- Hill-start aid 162
- Hill hold 160
- Control lamp 160
- Start-Stop system 161
- Warning lamp 160
- Horn 11
- I**
- Identification number 281
- Identification plate 281
- Ignition
 See "Engine and ignition" 119
- Ignition key
 see vehicle key 29, 30
- Ignition lock 120
- Safety interlock 121
- Unauthorised vehicle key 120
- Immobilizer 122
- Operating fault 119
- In case of a breakdown
 Securing the vehicle 240
- In case of an emergency
 Checklist 240
- Hazard warning lights system 240
- In case of a breakdown 240
- Protecting yourself and securing the vehicle 240
- In case of emergency 240
- Indicator
 Checking the engine oil level 185
- Engine oil pressure 185
- Information on consumption 282

- Initial operations
 Changing bulbs 265
- InSP Indicator 21
- Instrument panel 15
 Display 19
 Display control functions 22
- Instruments 18
- Lighting 88
 Screen 18
 Service interval display 21
 Symbols 15
 Warning lamp 15
 Warning lamps 15
- Instruments 18
- In the event of an emergency
 Fire extinguishers 242
 First aid kit 242
 Warning triangle 242
- ISOFIX 81
 see Child seat 76
- J**
- Jack 250
 Raising the vehicle 253
- Journey preparations 25
- K**
- Kerb weight 281
- key
 see vehicle key 30
- Key
 see vehicle key 29
- Key switch
 Deactivating the front passenger airbag .. 73
- Kickdown 131
- L**
- Labels 233
- Laser sensor 157
- LATCH 81
 see Child seat 76
- Lifting platform 231
- Lights 84
 Audible warnings 86
 Controls lighting 88
 Daytime driving light 87
 Dipped beam headlights 86
 Fog lights 86
 Functions 87
 Headlight range control 88
 Instrument panel lighting 88
 Instruments lighting 88
 Light switch 86
 Main beam lever 85
 Parking light remains on both sides 87
 Reading light 88
 Side lights 86
 turning off 86
 turning on 86
 Turn signal lever 85
 Warning lamps 84
- Load
 Driving with the rear lid open 98
 Transporting a load 98
- Loading 100
 General tips 97
 Loading luggage compartment 100
 Roof carrier system 105
- Locking
 from the exterior 34
 from the inside 36
 Rear lid 41
- Luggage compartment
 Rear shelf 102
- M**
- Main beam headlights 86
- Main beam lever 85
- Main panel
 Turn signal and main beam lever 85
- Malfunction
 automatic gearbox 132
 Catalytic converter 236
- Manual gearbox 124
 see also Changing gear 124
- Manufacturer identification plate 281
- mechanical locking
 locking and unlocking from the exterior ... 34
 locking and unlocking from the inside 36

- Mirrors
 Convenience functions 95
 Exterior mirrors 95
 Rear vision mirror 95
- Mobile telephone
 Using without an exterior aerial 227
- Modifications 224, 233
- Modifications to the vehicle 222
 Labels 233
 Plates 233
- N**
- Natural gas 178
 Fuel 178
 refuelling 175
 Types 178
- New engine 223
- New tyres 213
- New tyres and wheels
 About your tyres and wheels 211
- Noises
 Assisted braking systems 141
 Engine 122
- Notes for the user 233
- Number of seats 48
- O**
- Octane rating 177
- Odometer 18
- Off road driving
 Protection of the undercarriage 25
- Oil
 See engine oil 185
- Older tyres 211
- Onboard diagnostic system (ODB) 227
- Open
 Sliding/tilting electric panoramic sunroof . 44
- Opening
 Doors 38
 from the exterior 34
 from the inside 36
 The rear lid 41
 Windows 43
- Opening doors individually 33
- Operating fault
 Immobilizer 119
- Operating faults
 Radio reception 117, 234
- Optical parking system (OPS) 150
- Outside temperature indicator 20
- Overview
 Control lamps 15
 Driver door 9
 Front view 7
 Instruments 18
 Rear view 8
 Roof 14
 Side view 6
 The driver's side 10
 Warning lamps 15
- P**
- Parking 134, 136
 Parking aid 150
 Parking distance warning system 149
 Fault 150
 Optical parking system (OPS) 150
 Using high pressure cleaning apparatus . 199
- Parking light 87
 Parking light remains 87
- ParkPilot 150
- Pedals 50, 127
- Petrol 177
 Additives 177
 Fuel 177
 Fuel gauge 172
 Refuelling 174
 Types 177
- Plates 233
- Polishing 202
- Pollen filter 164
- Pollution filter 164
- Portable Navigation System 229
- Preparation
 Checking the engine coolant level 191
 Tire Mobility Set 258
 Vehicle battery 194
 Work in the engine compartment 182
- Preparations
 before each journey 25
 Changing a wheel 251

Checking the engine oil level	186
Topping up the engine oil level	186
Principles of physics regarding a frontal collision	59
Problems	238
Protection of the undercarriage	25
Protection of vehicle undercarriage	203
Pushing	119

R

Radio reception	
Aerial	234
Operating faults	117, 234
Raising the vehicle	
Check list	254
Jack	253
Raising vehicle	
Lifting platform	231
With a lifting platform	231
Reading light	88
Reading the	
Fault memory	227
Rear backrest	
Folding	101
Lifting up	101
Rear head restraints	
Adjustment	52
removing and fitting	53
Rear lid	40
Closing	41
Driving with the rear lid open	98
Emergency locking and unlocking	244
see rear lid	34
See "Rear lid"	40
unlocking and locking	34
Rear seat bench	101
Rear vision mirror	95
Rear vision mirrors	95
Recommended gear	132
Recycling	235
Refuelling	171
At the filling station	171
Control lamp	172
Fuel	174
Fuel gauge	172
Mistakes	172
Natural gas	175
Petrol	174
Refuelling precautions	176
Refuelling precautions	176
Remote control key	
see vehicle key	29
Removing ice	200
Removing snow	200
Removing wax deposits	200
Repairs	222, 224
Airbag system	225
Labels	233
Lifting platform	231
Plates	233
Replacement of parts	222, 223
Reprogramming control units	227
Retaining hooks	103

Retro-fitting	
Two-way radios	226
Vehicle telephone	226
Rev counter	18
Roof carrier system	104
Rubber seals	203
Running-in	
Brake pads	137
First trips	223
Tyres	213
Wheels and tyres	213
Running-in brake pads	
Also see "Brakes"	137
Running in	
Engine	223

S

Safe driving	25
Safety Assist	155
Safety equipment	70
Sale of vehicle	
In other countries / continents	234
Salt water	27
Scrapping	235
Screen	18
Seat belt position	63
Seat belt protection	61
Seat belts	
Automatic belt retainer	65
Belt tension device	65
Belt tension limiter	65

- Checklist 61
- Fastening 62
- Seat belt position 63
- Seat belt status display 58
- Twisted belt 62
- Unfastened 60
- Unfastening 62
- Use 61
- Warning lamp 58
- Seat belt warning lamp 58
- Seat functions 55
- Seat heating 55
- SEAT information system 22
- Seats 48
 - Adjusting the steering wheel position 53
 - Adjust the rear head restraints 52
 - Correct position 50
 - Fitting the rear head restraints 53
 - Front seat 51
 - Heated seats 55
 - Number of seats 48
 - Rear backrest 101
 - Removing and fitting rear head restraints 53
- Service interval display 21
- Set
 - Air conditioner 167
- Side airbags
 - See "Airbag system" 75
- Side lights 86
- Sitting position
 - Incorrect position 49
- Sliding/tilting electric panoramic sunroof 44
- Anti-trap function 46
- Close 45
- Open 45
- Small window 90
- Snow chains 220
- Temporary spare wheel 221
- Socket
 - 12 Volts 118
- Spare fuel canister 171
- Spare key
 - see vehicle key 29, 30
- Spare parts 223
- Spare wheel 217
 - Driving advice 217
 - removing 217
- Special features
 - Automatic car wash 199
 - High pressure cleaning equipment 199
 - Parking 134, 137, 290
 - Pushing 119
 - Radio reception 234
 - Removing the vehicle key 121
 - Towing 119
 - Washing the vehicle 198
 - Windscreen wipers 92
- Special notes
 - Long parking times 33
 - Towing 276, 277
 - Tow starting 277
- Speed rating 220
- Start-Stop 161
- Start-Stop system 161
- Starting assistance 273
 - Description 274
 - Jump leads 274
- Starting using an external battery
 - See starting assistance 273
- Steering 147
 - Control lamp 147
 - Electromechanical 148
 - Power steering 148
 - Steering column lock 148
 - Tendency to pull to one side 216
 - Warning lamp 147
- Steering wheel
 - Adjustment 53
- Storage compartment
 - Centre console 111
 - Driver side 109
- Storage compartments 108
- Sudden braking 241
- Sun blind 89
- Sunglasses storage compartment 110
- Sun visor 89
- Symbols
 - see warning lamp 15
- Systems
 - ABS 140
 - Anti-lock brake system (ABS) 140
 - ASR 140
 - BAS 140
 - Brake assist system (BAS) 140
 - Cruise control system (CCS) 152

- EDL 140
 - Electronic differential lock system (EDL) . 140
 - electronic stability control (ESC) 139
 - ESC 139
 - Hill hold 160
 - Optical parking system (OPS) 150
 - Parking aid 150
 - Parking distance warning system 150
 - Safety Assist (City Safety Assist function) 155
 - TC 140
 - Traction control system (ASR) 140
 - Traction Control (TC) 140
- T**
- Tank flap
 - close 175
 - Natural gas 175
 - open 175
 - TC
 - see Brake assist systems 140
 - Technical data
 - Axle loads 281
 - Bottle capacity 94
 - Capacities 290
 - Engine oil specifications 185
 - Identification plate 281
 - Kerb weight 281
 - Manufacturer identification plate 281
 - Roof load 105
 - Total weight 281
 - Tyre pressures 214
 - Vehicle data label 281
 - Weights 281
 - Technical information
 - Type of fuel 177
 - Technical modifications 224
 - Labels 233
 - Lifting platform 231
 - Plates 233
 - Technical specifications 280
 - Dimensions 290
 - Temperature display
 - Liquid coolant temperature 23
 - Outside temperature 20
 - Temporary spare wheel 217
 - Driving advice 217
 - Snow chains 221
 - The rear lid
 - Opening 41
 - Unlocking 41
 - Things to note
 - Disconnecting the vehicle's battery 21
 - parking distance warning system 150
 - Water underneath the vehicle 168
 - Tightening torque
 - Wheel bolts 252
 - TIN 219
 - Tips for driving 25
 - Before starting out 25
 - Tiptronic 130
 - tire mobility set
 - Components 257
 - Tire Mobility Set
 - Check after 10 minutes 259
 - Do not use 256
 - Inflating a tyre 258
 - preparation 258
 - Sealing a tyre 258
 - see Anti-puncture kit 256
 - Tools
 - see Vehicle tool kit 246
 - Total weight 281
 - Towing 119, 276
 - Driving advice 278
 - Front tow ring 278
 - Special notes 276, 277
 - Tow bar 277
 - Tow rope 277
 - Tow starting 277
 - Traction 219
 - Traction control system (ASR) 140
 - Traction Control (TC) 140
 - Trailer coupling
 - Towing bracket 107
 - Transporting 97
 - Transporting a load 98
 - Transporting a load 98
 - Transporting children in the vehicle 77
 - Checklist 77
 - Transporting objects
 - Driving advice 99
 - Driving with the rear lid open 98
 - Retaining hooks 103
 - Roof carrier system 104, 105

- Tread depth 215
Treadwear 219
Trip meter 18
Turn signal convenience function 85
Turn signal lever 85
Two-way radios 226
Type of fuel 177
Tyre load rating 220
Tyre pressure
 Spare wheel 215
 Temporary spare wheel 215
Tyre pressures 214
Tyre repair kit
 see Anti-puncture kit 256
Tyres with directional tread pattern 220
- U**
- Unlocking
 from the inside 36
Upholstery 205
 Check list 206
 Fabric trim cleaning 206
 Padding cleaning 206
 Treating your upholstery 206
- V**
- Valve caps 215
Vehicle
 Collection 235
 Loading 97
 locking and unlocking from the exterior ... 34
 locking or unlocking from the inside 36
 Parking downhill 137
 Parking uphill 137
 Recycling 235
 Securing in case of a breakdown 240
Vehicle battery 193
 Acid 195
 Discharging 121
 Explanation of symbols 193
 Location 193
 Preparation 194
 Starting assistance 274
 Warning lamp 194
Vehicle care
 Aerial built into the window 234
 Airbag modules (dash panel) 208
 Aluminium wheel rims 202
 anodized surfaces 202
 Automatic car wash 198
 Changing windscreen wiper blades 201
 Chrome wheel rims 202
 Cleaning compartments 207
 Cleaning seat belts 208
 Cleaning wheel rims 203
 Cleaning windscreen wiper blades 201
 Dash panel 208
 De-icing the door lock cylinder 203
 Engine compartment 204
 Exterior mirrors 200
 Fabric trim 206
 High pressure cleaning apparatus 199
 Padding 206
 Plastic parts 208
 Protection of vehicle undercarriage 203
 Rubber seals 203
 Special features 198, 199
 Treating your upholstery 206
 Vehicle paintwork 202
 Washing by hand 198
 Washing the vehicle 198
 Windows 200
 Windscreen wipers service position 93
 Wooden trim 208
Vehicle code
 Vehicle data label 281
Vehicle data label 281
Vehicle diagram
 Front view 7
 Rear view 8
 Side view 6
Vehicle identification data 281
Vehicle identification number 281
Vehicle key
 assign 29, 30
 Changing the battery 31
 control lamp 30
 Synchronising 31
Vehicle key set 28
Vehicle mechanical key 30
Vehicle telephone 226
Vehicle tool kit 246
 Components 247
 Location 246

- Vehicle's battery
 - Automatic consumer disconnection 196
 - Charging 195
 - Checking the electrolyte level 194
 - Connecting 195
 - Disconnecting 195
 - Replacing 195
 - Running flat 196
 - Vibrations
 - Steering 216
- W**
- Warning and control lamps
 - Changing gear 125
 - Warning lamp
 - Alternator 194
 - Brake system 135
 - City Safety Assist function 156
 - Engine coolant 189
 - Hill hold 160
 - Overview 15
 - Seat belts 58
 - Vehicle battery 194
 - Warning lamps
 - Lights 84
 - Warning triangle 242
 - Washing 197
 - by hand 198
 - with high pressure cleaning apparatus 199
 - Washing the vehicle 198
 - Sensors 149
 - Special features 198
 - Water box 204
 - Wear indicators 216
 - Wear of tyres 216
 - Weights 281
 - Wheel bolts 250, 251
 - Caps 249
 - Tightening torque 252
 - Wheel load capacity 219
 - Wheel rims 212
 - Beadlock 212
 - See "Wheels and tyres" 210
 - Wheels and tyres 210
 - Avoiding damage 211
 - Changing a wheel 250
 - Code 218
 - Damaged tyres 216
 - Errors in wheel alignment 217
 - Foreign bodies in the tyres 216
 - Interchanging tyres 211
 - New tyres 213
 - Older tyres 211
 - Replacing tyres 213
 - Run-out 216
 - Serial number 219
 - Snow chains 220
 - Spare wheel 217
 - Speed rating 219, 220
 - storing the replaced wheel 217
 - Storing tyres 212
 - Technical data 218
 - Temporary spare wheel 217
 - Tread depth 215
 - Tyre code 218
 - Tyre identification number (TIN) 219
 - Tyre load rating 220
 - Tyre pressures 214
 - Tyres with directional tread pattern 211, 220
 - Valve caps 215
 - Wear indicators 216
 - Wear of tyres 216
 - Wheel balance 216
 - Wheel rims 212
 - Wheel trims 248
 - Bolted trims 212
 - Full hub caps 249
 - Hub caps 248
 - Wheel bolts caps 249
 - Windows 43
 - Windscreen
 - Heat-insulating glass 90
 - Windscreen washer 91
 - Windscreen washer water
 - Checking 93
 - Topping up 93
 - Windscreen wiper 91
 - Windscreen wiper lever 91
 - Windscreen wipers
 - Functions 92
 - Headlight washer system 92
 - Heated windscreen washer jets 92
 - Lifting the wiper blades 93
 - Replacing the wiper blades 93
 - Service position 93
 - Special features 92
 - Windscreen wipers service position 93
 - Windscreen with metal coating 90

Windscreen with reflective infrared coating . . . 90

Other Characters

¿What happens if...? 238


SEAT S.A. is permanently concerned about continuous development of its types and models. For this reason we ask you to understand, that at any given time, changes regarding shape, equipment and technique may take place on the car delivered. For this reason no right at all may derive based on the data, drawings and descriptions in this current handbook.

All texts, illustrations and standards in this handbook are based on the status of information at the time of printing. Except for error or omission, the information included in the current handbook is valid as of the date of closing print.

Re-printing, copying or translating, whether total or partial is not allowed unless SEAT allows it in written form.

SEAT reserves all rights in accordance with the "Copyright" Act.

All rights on changes are reserved.

 This paper has been manufactured using bleached non-chlorine cellulose.

© SEAT S.A. - Reprint: 15.07.12

Inglés 1SL012003T (07.12)



1SL012003T

